

Non-Confidential

**CORE & TUPPER MAIN
REGISTERED SUPPLEMENT**

EMERGENCY RESPONSE PLAN



24-Hour Emergency Number

1-844-667-8477

BCER Emergency Number

1-800-663-3456

AER Emergency Number

1-800-222-6514

March 2026



EMERGENCY RESPONSE PLAN

Prepared by:

BLACK GOLD Emergency
Planners Inc
An FM Safety Services Ltd. Company



2026

MANAGEMENT OF CHANGE LOG

Annual Review Date: March 31, 2026
Annual Update Due: March 31, 2027 **Signature: _____**

Date Completed (DD/MM/YYYY)	Revision #	Section(s) Updated	Description	Revision ¹	Annual Update ²
31/March/2026	4	All	Entire Document Updated to Version 4.2	<input type="checkbox"/>	<input checked="" type="checkbox"/>
29/April/2025	3	Admin	Updated entire section.	<input type="checkbox"/>	<input checked="" type="checkbox"/>
		Section 1	The Initial Response Section has been relocated to be Section 1. Updated template.		
		Section 2	The EOC Telephone List / Policy Statement has been relocated to be Section 2.		
		Section 3	Updated the Field Response Team – Roles and Responsibilities entire section.		
		Section 6	6.5.3 Updated the Command Centre Communication Flow Diagram. 6.7.1 Updated the External Notification Flow Chart.		
		Section 7	7.6 Removed “First Aid Measures:” 7.23.2 Updated ERG date to 2024 7.31.6 Updated “After an Earthquake” link		
		Section 9	9.2.7 Updated Fire Hazard and NOTAM to NOTAM		
		Section 10	The Appendix Section has been relocated to be Section 10.		
		Section 11	Added Administration Forms.		
		Section 12	The Operations Section has been relocated to be Section 12. Refer to the Site Specific Registered Supplement for the applicable MOC Log.		
29/April/2024	2	Admin	Updated entire section.	<input type="checkbox"/>	<input checked="" type="checkbox"/>
		Section 2	Updated Field Section name.		
		Section 3	Updated Command Structure Chart and Roles & Responsibilities.		
		Section 4	Updated Command Structure Chart and Roles & Responsibilities.		
		Section 6	Updated Command Structure Chart.		
		Section 9	9.1 Updated AB Jurisdictional section. 9.2 Updated BC Jurisdictional section.		
		Section 11	Removed AB First Call Communication Form. Updated ICS Form with new Command Structure Chart.		

Date Completed (DD/MM/YYYY)	Revision #	Section(s) Updated	Description	Revision ¹	Annual Update ²
12/March/2024	1	Admin	Updated entire section.	<input type="checkbox"/>	<input checked="" type="checkbox"/>
		Section 9	9.1 Updated Alberta Jurisdictional section. 9.2 Updated BC Jurisdictional section		
		Section 11	Updated BC Post Incident Report Form		
30/April/2023	New	All	New ERP Document	<input type="checkbox"/>	<input checked="" type="checkbox"/>

¹ **Revision:** An interim revision to the ERP when significant changes occur to Company personnel or infrastructure (drilling, facilities, pipelines). A revision does not replace the requirement for an annual update.

² **Annual Update:** A comprehensive update to all sections of the ERP. The entire document is reviewed and updated to ensure current distribution list, emergency telephone list, roles and responsibilities, mutual aid agreements, response agencies information, government support information, asset tables, safety equipment, and maps. In a Registered Site-Specific ERP, the stakeholder database is also verified, a hazard assessment is conducted, and area user contact information is updated.

DISCLAIMER

This Emergency Response Plan and all associated templates, formats, layouts, and instructional content are the proprietary property of Black Gold Emergency Planners Inc. and are protected under Canadian copyright, intellectual property, and trade name legislation.

This plan is provided exclusively for the use of NorthRiver for the purpose of supporting a structured and responsible approach to classifying and responding to emergency situations. This plan identifies, defines, and recommends actions related to incidents that may impact facilities covered under the plan.

No portion of this plan—including its structure, wording, formatting, graphics, maps, or procedures—may be copied, reproduced, modified, distributed, transmitted, shared, or used to create derivative works without the prior written consent of Black Gold Emergency Planners Inc.

Unauthorized reproduction or use of this plan, in whole or in part, is strictly prohibited.

Verification of the accuracy of company-specific information contained within this plan is the sole responsibility of NorthRiver Black Gold Emergency Planners Inc. assumes no liability arising from the implementation or operational use of this plan.

The Emergency Response Plan must be available on site at all times as required by applicable regulatory agencies.

This plan has been professionally prepared and administered by:



Black Gold Emergency Planners, an FM Safety Services Ltd. Company

Delivering an integrated industrial safety services platform to clients across Canada and the United States, ensuring comprehensive safety coverage from prevention and preparedness to rapid response and incident mitigation.

████████████████████
Mountainview Business Campus
Suite 212, 4000 – 4th Street SE
Calgary, AB T2G 2W3

Office: 403-216-7052

TABLE OF CONTENTS

TABLE OF CONTENTSi

DISTRIBUTION LIST 1

1.0 INITIAL RESPONSE 1

1.1 Initial Response Flowchart..... 1

1.2 Size-Up the Situation Form.....3

1.3 Six-Step Initial Response Guide5

1.4 Step 1 – Situation Assessment.....6

1.4.1 British Columbia Incident Classification Matrix.....6

1.4.2 Alberta Assessment Matrix for Classifying Incidents.....7

1.5 Step 2 – Establish Command9

1.6 Step 3 – Coordinate Internal Notification10

1.7 Step 4 – Undertake External Notification11

1.7.1 British Columbia Notification Requirements for Key Government Agencies and Local Resources (BC)12

1.7.2 Alberta Notification Requirements for Key Government Agencies and Local Resources (AB)13

1.8 Step 5 – Run Briefing14

1.8.1 Incident Priorities Chart15

1.9 Step 6 – Ensure Public Safety16

1.9.1 Public Protection Measures Flowchart (BC).....16

1.9.2 Public Protection Measures Flowchart (AB).....17

2.0 CEOC TELEPHONE LIST / POLICY STATEMENT 1

2.1 Corporate Contact List..... 1

2.2 Emergency Management Policy Statement..... 1

3.0 SITE INCIDENT COMMAND STRUCTURE - ROLES AND RESPONSIBILITIES 1

3.1 Site Command Chart 1

3.2 First Responder2

3.3 Incident Commander 3

3.4 Site Operations Section Chief..... 7

3.5 Public Protection Group Supervisor.....10

3.5.1 Roadblock Team Leader12

3.5.2 Rover Evacuation Team Leader.....14

3.5.3 Air Quality Monitoring Team Leader.....16

3.5.4 Reception Team Leader.....18

3.5.5 Telephone Team Leader20

3.6 On-Site Group Supervisor22

3.6.1 On Site Safety Team Leader24

3.6.2 Fire Control Team Leader26

3.6.3 Isolation/Repair Team Leader27

3.6.4 Spill Response Team Leader28

3.6.5 Security Team Leader30

3.6.6 Ignition Team Leader31

3.7 Staging Area Manager.....33

3.8 Site Safety Officer.....34

3.9 Site Liaison Officer36

3.10 Site Scribe37

3.11 Site Planning Section Chief38

3.12 Site Logistics Section Chief39

3.13 Site Admin/Finance Section Chief40

4.0	CEOC INCIDENT COMMAND STRUCTURE - ROLES AND RESPONSIBILITIES	1
4.1	CEOC Command Chart	1
4.2	CEOC Director	2
4.3	CEOC Operations Chief	3
4.4	CEOC Liaison Officer	5
4.5	CEOC Information Officer	6
4.6	CEOC Risk Management Officer	8
4.7	CEOC Planning Chief	9
4.7.1	Engineering	10
4.7.2	Human Resources	11
4.7.3	Legal	12
4.8	CEOC Logistics Chief	13
4.9	CEOC Finance Chief	14
4.10	CEOC Administration/Scribe	15
5.0	COMMAND CENTRES AND RESPONSE LOCATIONS	1
5.1	On-Site Command Post (OSCP)	1
5.2	Incident Command Post (ICP)	1
5.3	Staging Area	1
5.4	Reception Centre	1
5.5	Helibase	2
5.6	Helispot	2
5.7	Corporate Emergency Operations Centre (CEOC)	2
5.7.1	Suggested Equipment and Supplies for the CEOC	3
5.8	Government Command Posts	4
5.8.1	Regional Emergency Operations Centre (REOC)	4
5.8.2	Municipal Emergency Operations Centre (MEOC)	4
5.8.3	Government Emergency Operations Centre (GEOC)	4
6.0	CRISIS COMMUNICATION PLAN	1
6.1	Purpose of the Crisis Communication Plan	2
6.2	Crisis Communication Policy	2
6.3	Crisis Communication Plan Objectives	2
6.4	Crisis Communication Audiences	2
6.5	Internal Communication and Command Centres	3
6.5.1	Communication at On-site Command Post	3
6.5.2	Communication at Incident Command Post	3
6.5.3	Communication at the Corporate Emergency Operations Centre (CEOC)	3
6.5.4	Communication with the Executives: President and Board of Directors	3
6.6	Crisis Communication Process	4
6.6.1	24-Hour Emergency Number	4
6.6.2	Public Inquiry	4
6.6.3	Command Centre Communication Flow Diagram	5
6.7	External Communication	6
6.7.1	Communication with Government/Regulatory	6
6.7.2	Communication with the Public	6
6.8	Media Communication	7
6.8.1	Media Crisis Communication Policy	7
6.8.2	Media Access to Emergency Site	8
6.8.3	Preliminary Holding Statement	8
6.8.4	General Guidelines	9
6.8.5	Media Release	11

6.8.6	Crisis Media Interview	12
6.8.7	News Conference Guidelines	13
6.8.8	Reporting.....	13
6.9	Social Media	14
6.10	Mutual Aid Agreements	14
6.11	Emergency Answering Procedures	14
6.11.1	General Evacuation Script	15
6.11.2	Shelter in Place Script.....	16
6.11.3	Urgent Evacuation Script	17
6.11.4	Notification Script.....	18
7.0	RESPONSE ACTION PLANS AND PROCEDURES	1
	Emergency Response Action Guidelines for Site and Corporate Command	1
7.1	Purpose	1
7.2	Incident Site Worker Protection	1
7.3	Personal Protective Equipment (PPE).....	1
7.3.1	Protection Levels.....	1
7.4	Hazard Monitoring Procedures	2
7.4.1	Stationary and Mobile Air Quality Monitoring Units	2
7.4.2	Personal Handheld Monitors	4
7.5	Isolation Procedures	5
7.5.1	Suggested Roadblock Equipment	6
7.5.2	Setting up a Roadblock	7
7.6	Evacuation or Shelter in Place Procedures	8
7.6.1	General Shelter in Place Procedures	9
7.6.2	Post Shelter in Place Procedures.....	9
7.7	Health and Safety Plan	10
7.7.1	Product Specific Information	10
7.7.2	Responder Safety and Protection	10
7.7.3	Site-Specific Information	11
7.8	Public Safety and Protection.....	11
7.9	Site Security	12
7.9.1	Safety.....	12
7.9.2	Cyber Security.....	12
7.10	Injury/Fatality	14
7.10.1	Serious Injury/Fatality Safety	14
7.10.2	Action Plan for a Serious Injury/Fatality	15
7.10.3	Next of Kin Notification.....	18
7.11	Missing Worker.....	19
7.11.1	Response Plan for Missing Worker.....	19
7.12	Air Ambulance	19
7.12.1	Command Control.....	19
7.12.2	Landing Zone	20
7.12.3	Ground Operations	20
7.12.4	Loading and Unloading	20
7.12.5	Hazards and Special Situations	21
7.12.6	Approach Routes	21
	Incident Specific Initial Response Actions and Procedures	22
7.13	Spill Contingency Plan.....	22
7.13.1	Spill Preparedness Risk Analysis	22
7.13.2	Seven Step Guideline for Spill Response	22

7.13.3	Company Spill Discovery and Response Actions	27
7.13.4	Spill Management Techniques.....	30
7.14	Sour Gas Release	36
7.14.1	Critical Sour Wells – Sour Release from a Manned Operation	36
7.14.2	Non-Critical Sour Gas Release from an Unmanned Operation	36
7.14.3	Sour Gas Release Site Safety	37
7.15	Sweet Gas (Hydrocarbon) Release	38
7.15.1	Flammability Limits	39
7.16	Hydrocarbon Exposure	39
7.16.1	Exposure to Heat Radiation (ignited hydrocarbon release)	39
7.17	Liquids Release – Site/Facility	40
7.17.1	Liquid Release Site Safety	40
7.17.2	Action Plan for Liquids Release	40
7.18	Well Kick Incident	43
7.18.1	Well Kick Site Safety	43
7.19	Blow Out Incident	44
7.19.1	Blow Out Incident Safety	44
7.19.2	Action Plan for Blowout Incident	44
7.20	General Fire Response	46
7.20.1	Facility Fire Safety	47
7.20.2	Action Plan for Facility Fires	47
7.21	High Vapour Pressure (HVP) Release	49
7.21.1	HVP Product Release Monitoring	49
7.21.2	Ignition Considerations	50
7.21.3	Guideline for Igniting HVP Plume	50
7.22	Pressurized Fuel Fire	51
7.23	Propane or LPG Tank Fire.....	52
7.23.1	Boiling Liquid Expanding Vapour Explosion (BLEVE).....	52
7.23.2	How big is the fireball from a Propane or LPG BLEVE?	53
7.23.3	Fire Fighting a BLEVE	55
7.24	Transportation Incident.....	55
7.24.1	Transportation Incident Safety	55
7.24.2	Action Plan for Transportation Incident.....	56
7.25	Product Transportation Incident.....	58
7.26	Hazardous Materials Incident.....	59
7.26.1	Hazardous Material Safety.....	59
7.26.2	Action Plan for Hazardous Material Incident.....	59
7.27	Severe Weather Incidents	61
7.27.1	Severe Weather Safety.....	61
7.27.2	Wildfire.....	62
7.27.3	Tornadoes.....	63
7.27.4	Lightning	63
7.27.5	Floods.....	64
7.27.6	Seismicity.....	64
7.28	Wildlife	66
7.28.1	Wildlife Incidents and Mortalities.....	66
7.28.2	Wildlife Awareness.....	66
7.28.3	Working in Wildlife Habitat	66
7.28.4	Bears	66
7.28.5	Elk.....	68
7.28.6	Moose.....	68

9.4	CANADIAN FEDERAL GOVERNMENT	1
9.4.1	Royal Canadian Mounted Police (RCMP)	1
9.4.2	Environment and Climate Change Canada	1
9.4.3	Department of Fisheries and Oceans (DFO)	8
9.4.4	Public Safety Canada	8
9.4.5	Transport Canada – Transportation of Dangerous Goods	9
9.4.6	Transportation Safety Board	15
9.4.7	Health Canada	17
9.4.8	Public Health Agency of Canada	17
9.4.9	Indigenous Services Canada (ISC)	17
9.4.10	Indian Oil and Gas Canada	18
9.4.11	ERAC – A Not-For Profit Organization	19
9.5	CANADA ENERGY REGULATOR	1
9.5.1	Contact Information	2
9.5.2	Roles and Responsibilities	2
9.5.3	CER Definitions of Incident and Emergency	3
9.5.4	CER Event Reporting	4
9.5.5	Notifications and Preliminary Incident Reports	5
9.5.6	Detailed Incident Reports	6
9.5.7	Incident Costs	6
9.5.8	Published Manuals	7
10.0	FORMS	1
10.1	Initial Emergency Response Form	2
10.1.1	Form A1	2
10.2	Jurisdictional Forms	4
10.2.1	British Columbia Forms	4
10.2.2	Alberta Forms	14
10.3	ICS Forms	23
10.4	ERP Forms	47
10.5	Stakeholder Forms	59
10.6	Media Forms	63
10.7	Administration Forms	67
10.7.1	ERP Manual Receipt	67
10.7.2	Management of Change Request Form	68
11.0	APPENDIX	1
11.1	Risk Assessment	1
11.2	Setting up a Roadblock on a Roadway	3
11.3	CANUTEC 2024 – Hazard Reference Tables	6
11.4	Legal Survey Description (LSD) Reference Tool	10
11.5	National Topographic System (NTS) Reference Tool	11
11.6	HVP - Proposed EPZ Distances for Selected Diameters	12
11.7	Glossary	12
12.0	OPERATIONS	1

DISTRIBUTION LIST

Refer to each operation area's specific Emergency Response Plan for Distribution Lists.

1.0 INITIAL RESPONSE

1.1 Initial Response Flowchart

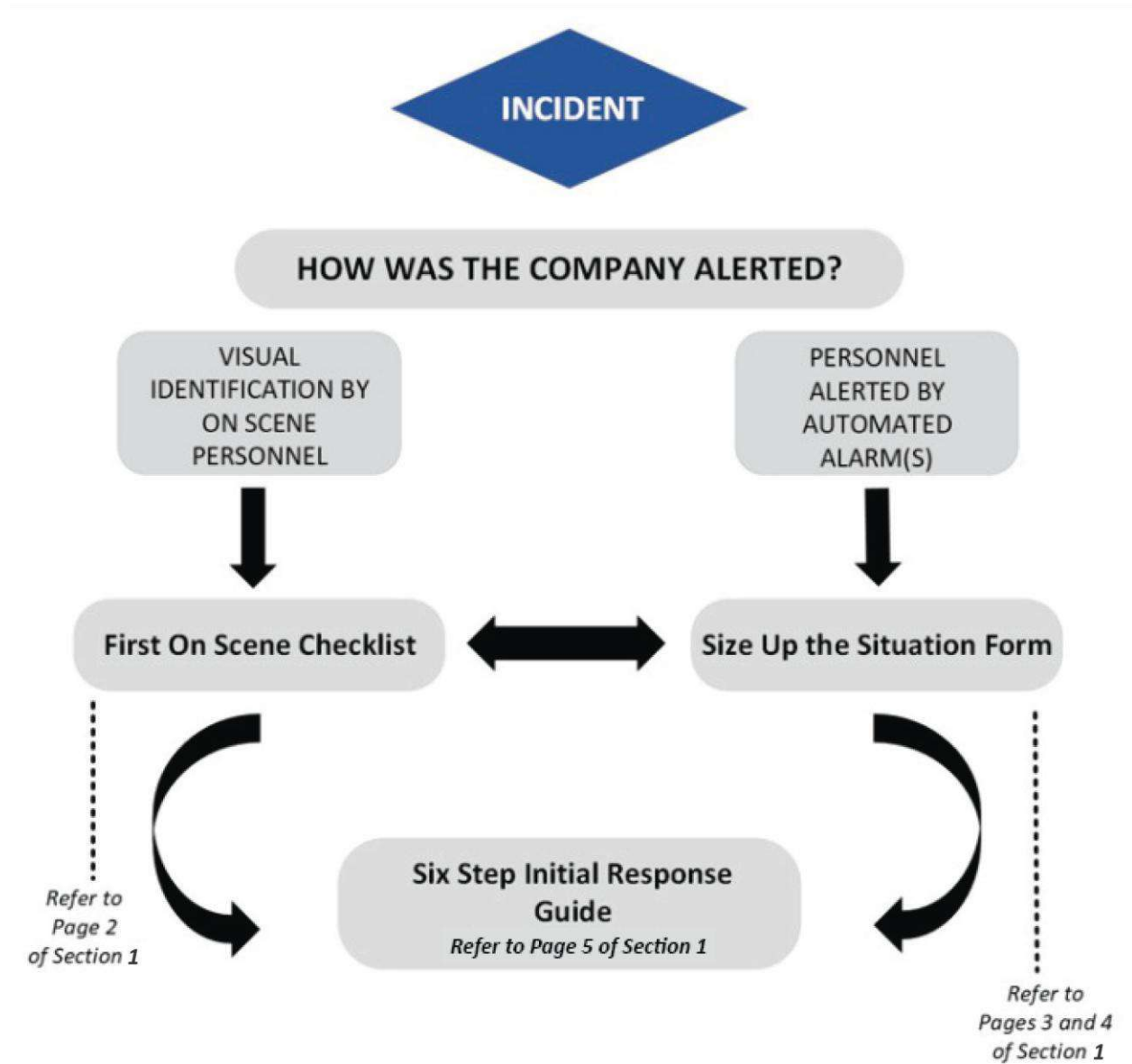

FIRST ON SCENE CHECKLIST	
INCIDENT PRIORITY	<ul style="list-style-type: none"> <input type="checkbox"/> Protection of Responder and/or Worker. <input type="checkbox"/> Protection of the Public. <input type="checkbox"/> Protection of the Environment and/or Property. <input type="checkbox"/> Reputation of the Company.
FIRST ON SCENE ACTIONS	<ul style="list-style-type: none"> <input type="checkbox"/> Always Assume Danger and Resist the Urge to Rush In Evacuate from any hazardous area any time you believe that the incident: <ul style="list-style-type: none"> • Has the potential to create. • Has the potential to migrate off-site or cause significant pollution. • Exceeds the facility's response capabilities at that time. • Is a significant natural disaster, fire, or act of subversion. • Is large or potential to become out of control. • Presents an unknown risk or hazard. <input type="checkbox"/> Sound alarm, call for help, or contact emergency services.
RESCUE OPERATIONS	<ul style="list-style-type: none"> <input type="checkbox"/> Initiate rescue operations (<i>If necessary AND safe to do so</i>) <ul style="list-style-type: none"> • Use the Buddy System. • Don all personal protection equipment (PPE). • Rescue victim to a safe area/revive victim. • Administer appropriate worksite First Aid procedures. <p><i>Confirm emergency services have been contacted</i></p>
ON-SITE COMMAND, CONTROL AND CONTAINMENT ACTIONS	<ul style="list-style-type: none"> <input type="checkbox"/> Senior most trained personnel on-scene become the Incident Commander <input type="checkbox"/> If life safety is assured, take actions to gain control/isolate/de-pressure the incident following safe work procedures: <ul style="list-style-type: none"> • Inspect the site from a distance. • Ensure appropriate personal protection (PPE) and detection equipment is available and functioning properly. <ul style="list-style-type: none"> - <i>Does the equipment need to be intrinsically safe?</i> • Approach from an upwind or crosswind direction, staying within visual contact and calling distance from your buddy. <ul style="list-style-type: none"> - <i>As the responder conducts monitoring, the back-up responder will maintain communication and be prepared for rescue.</i> • Check for toxic or explosive gases – smell or sight alone should not be trusted to determine if a hazard exists. • Ensure ambient air concentrations are monitored continuously. <ul style="list-style-type: none"> - <i>All personnel should evacuate the area if concentration are, or become, hazardous.</i> • Avoid extinguishing an ignited release if leak or supply cannot be stopped. • Responders should not attempt to battle any fire without site knowledge, risk assessment of factors, adequate firefighting equipment, training, and back-up personnel. • Inform first responders (including external personnel) about all hazards. <ul style="list-style-type: none"> - <i>DO NOT allow first responders to enter the hazard area unless properly trained and equipped.</i> <input type="checkbox"/> Report full details needed to the Incident Commander

1.2 Size-Up the Situation Form

Size Up the Situation Form	
<i>To be completed by the person(s) involved or notified</i>	
Report Taken By:	Date: Time:
Name of Person Calling:	Caller Contact:
Incident Location:	
Incident Details:	
Agencies Notified	<input type="checkbox"/> Yes Which Agency? <input type="checkbox"/> No
Incident Status	<input type="checkbox"/> Incident contained or controlled <input type="checkbox"/> Intermittent control possible <input type="checkbox"/> Imminent control possible <input type="checkbox"/> Incident is uncontrolled
Site Type	<input type="checkbox"/> Well <input type="checkbox"/> Pipeline <input type="checkbox"/> Tank Farm Storage <input type="checkbox"/> Plant Battery Facility Other (please specify):
Incident Type	<input type="checkbox"/> Gas Release <input type="checkbox"/> Sour Gas? <input type="checkbox"/> Sweet Gas? <input type="checkbox"/> Pipeline Failure <input type="checkbox"/> Security (theft, vandal, threat) <input type="checkbox"/> Loss of Containment <input type="checkbox"/> Fire <input type="checkbox"/> Injury <input type="checkbox"/> Vehicle <input type="checkbox"/> Spill Other (please specify):
Impacts	
Distance to nearest surface development _____ km	Distance to nearest urban centre _____ km
Public Health and Safety	<input type="checkbox"/> Jeopardized <input type="checkbox"/> Could be Jeopardized
Public Protection Measures Implemented	<input type="checkbox"/> Notification <input type="checkbox"/> Evacuation <input type="checkbox"/> Shelter-In-Place <input type="checkbox"/> Roadblocks

Worker Injuries	<input type="checkbox"/> First Aid <input type="checkbox"/> Medical Aid <input type="checkbox"/> Hospital <input type="checkbox"/> Fatality			
	Other (please specify):			
Details:				
Release Impact	<input type="checkbox"/> On-Lease	<input type="checkbox"/> Off-Lease	Product	Amount
Gas Readings	H ₂ S	SO ₂	LEL	Other
Distance to Nearest Watercourse		km	Weather Conditions	
Details:				
Media Involvement	Regulator Involvement		Public Affairs/Community Relations Issues	
Yes <input type="checkbox"/> No <input type="checkbox"/>	Yes <input type="checkbox"/> No <input type="checkbox"/>		Yes <input type="checkbox"/> No <input type="checkbox"/>	
Problems:				

SIX STEP INITIAL RESPONSE GUIDE

- Situation Assessment
- Establish Command
- Coordinate Internal Notification
- Undertake External Notification
- Run Briefing
- Ensure Public Safety

Step 1 – Situation Assessment

After notification of an emergency incident the Emergency Response Plan (ERP) will be activated at any Level of Emergency.

- Levels of Emergency
- ☐ Alert/Minor
 - ☐ Level 1 Emergency
 - ☐ Level 2 Emergency
 - ☐ Level 3 Emergency

Note: Please refer to the jurisdictional matrix that is most applicable for the area of operations. If the incident overlaps more than one level on a matrix always choose the highest level.

Use the following resources:

- Initial Response Step 1 – Applicable Jurisdictional Assessment Matrix for Classifying Incidents

Step 3 – Coordinate Internal Notification – IC to Call/Email Area Director and Director HSE

- ☐ Determine internal personnel to be notified.
- ☐ Relay the information in the completed Size Up the Situation Form (Initial Response).
- ☐ Mobilize internal resources to the site, to the Incident Command Post (ICP) and to the Corporate Emergency Operations Centre (CEOC) or place them on standby as required.
- ☐ Area Directors will escalate to Senior Leadership Team and active the Corporate Emergency Operations Center.
- ☐ Area Director or designate will assume CEOC Director Role and support the IC.

Use the following resources:

- Operations - Telephone Directory
- Site and CEOC Command Structure - Roles & Responsibilities

Step 2 – Establish Command

Stand Up the Incident Command System

- ☐ Incident Commander will be assigned to the individual who has the highest qualifications and experience. (IC)
- ☐ Assign Site Safety Officer. (SO)
- ☐ Assign Site Liaison Officer. (LO) – External Notification
- ☐ Determine if other roles are needed to establish the field response team. Consider size and complexity

Use the following resources:

- Initial Response - Step 2 Establish Command
- Site ICS – Roles & Responsibilities

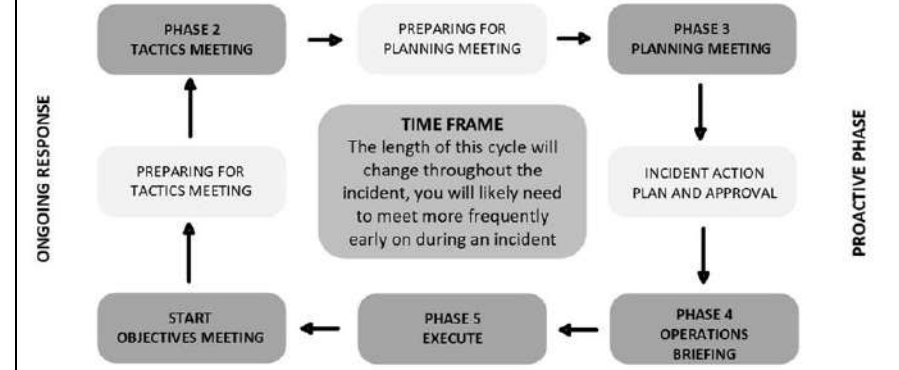

Step 4 – Undertake External Notification – Site Liaison Officer

- ☐ Follow the External Emergency Notification Flowchart and utilize the Operations section to determine which external agencies need to be notified.
- ☐ Regulatory agency to confirm the Level of Emergency.
- ☐ 911 (Police, Fire, Ambulance).
- ☐ Health Authority/Health Services.
- ☐ Local Authority (Cities, Towns, Villages, Counties, M.D.s, R.D.s, R.M.s, Special Areas, Reserves, etc.).
- ☐ Air Monitoring (at all levels of emergency).

Use the following resources:

- Crisis Communication Plan(s)
- Operations - Area Specific Information

Step 5 – Run Briefing – CEOC Information Officer/Site Safety Officer

Complete an ICS 201 Incident Briefing Form:

- ☐ Define incident details and an operational period (page 1).
 - Establish the On-Site Command Post (OSCP) and ICP
- ☐ Document current incident objectives, strategies, and tactics.
- ☐ Prioritize objectives.
- ☐ Define initial Incident Command Structure.
- ☐ Identify the required resources, and when they will be available.
- ☐ Identify Hazards and develop applicable safety plan(s).

Use the following resources:

- Initial Response: Size Up the Situation Form, Step 5 Incident Briefing (Incident Priorities)
- Forms (ICS 201, 202)

Step 6 – Ensure Public Safety

6.1 Activate Public Protection Measures – (Site Operations Section Chief)	6.2 Dispatch Rovers (Public Protection Group Supervisor)	6.3 Establish Telephone Team – (Public Protection Group Supervisor)
<ul style="list-style-type: none"> ☐ Determine the hazard area; start with Emergency Planning Zone (EPZ). ☐ Identify the affected surface developments and area users (residents, businesses, guides/outfitters, trappers, schools, other oil and gas operators, etc.). ☐ Determine the appropriate public protection measure for the affected surface developments and area users. (evacuation, shelter-in-place and/or ignition). ☐ Coordinate evacuation outside of the EPZ with the local authority (if required). ☐ Utilize broadcast media to notify the public outside of the EPZ in immediate evacuation situations. <p>Use the following resources:</p> <ul style="list-style-type: none"> • Initial Response - Public Protection Measures Flowchart • Response Action Plans (Public Safety and Protection) • Public Notification Flowchart • Operations - Area Specific Information 	<ul style="list-style-type: none"> ☐ Dispatch Rovers to patrol the EPZ. ☐ Follow all safety procedures and have all appropriate PPE. ☐ Search the EPZ for transients. ☐ Assist residents that require evacuation assistance. ☐ Investigate surface developments that are identified as vacant or those unable to contact. ☐ Post notices on all outside doors of empty surface developments, vehicles, etc. ☐ Record all contacts, communications and monitor readings using the following forms: ICS 214 & Environmental Monitoring Record. ☐ Monitor and record air quality readings using the following forms: ICS 214 & Environmental Monitoring Record (smoke, plumes, wind, etc.). ☐ Provide status updates to the Public Safety Group Supervisor at established intervals. <p>Use the following resources:</p> <ul style="list-style-type: none"> • Site ICS - Roles & Responsibilities (Rovers) • Forms • Operations - Area Specific Information 	<ul style="list-style-type: none"> ☐ Establish a Telephoner Team to notify residents to evacuate or shelter-in-place as required. ☐ Notify special needs residents at a Level 1 Emergency and provide the option to evacuate voluntarily. ☐ Removed Follow-up phone calls to address resident inquiries. ☐ Record all phone calls and communications using the following forms: ICS 214 & Stakeholder Forms ☐ Regularly provide status updates to the Public Safety Group Supervisor. <p>Use the following resources:</p> <ul style="list-style-type: none"> • Site ICS - Roles & Responsibilities (Telephone Team Leader) • Forms
<p>6.4 Establish Roadblocks (Public Protection Group Supervisor)</p> <ul style="list-style-type: none"> ☐ Follow safety procedures to safely establish roadblocks wherever a road intersects with the EPZ and advise vehicles to reroute. ☐ Record all vehicle encounters and air monitoring readings. Complete the following forms: ICS 214 and Roadblock Checkpoint Record. ☐ Gain permission from the Public Safety Group Supervisor for response vehicles to enter the hazard area. ☐ Provide status updates to the Public Safety Group Supervisor at established intervals. <p>Use the following resources:</p> <ul style="list-style-type: none"> • Site ICS - Roles & Responsibilities (Roadblocks) • Forms • Operations - Area Specific Information (Map) 	<p>6.5 Dispatch Air Monitors (Public Protection Group Supervisor)</p> <ul style="list-style-type: none"> ☐ Dispatch Air Monitoring personnel to the nearest residence/public facility downwind of the incident. ☐ Follow safety procedures and have appropriate PPE. ☐ Monitor and record air quality readings using the following forms: ICS 214 & Environmental Monitoring Record (Smoke, plumes, wind, etc.). ☐ Provide status updates to the Public Safety Group Supervisor at established intervals. <p>Use the following resources:</p> <ul style="list-style-type: none"> • Site ICS - Roles & Responsibilities (Air Monitors) • Forms 	<p>6.6 Establish Reception Center for Impacted Residents and Stakeholders (Public Protection Group Supervisor)</p> <ul style="list-style-type: none"> ☐ If residents are evacuated, dispatch a Reception Centre Representative to the reception center location. ☐ Meet and register evacuated residents. Record contact information for those who choose to stay elsewhere. Complete the following forms: ICS 214 & Stakeholder Forms ☐ Regularly provide status updates to the Public Safety Group Supervisor (those who have arrived and those who have not yet arrived). <p>Use the following resources:</p> <ul style="list-style-type: none"> • Site ICS - Roles & Responsibilities (Reception Centre Rep) • Forms

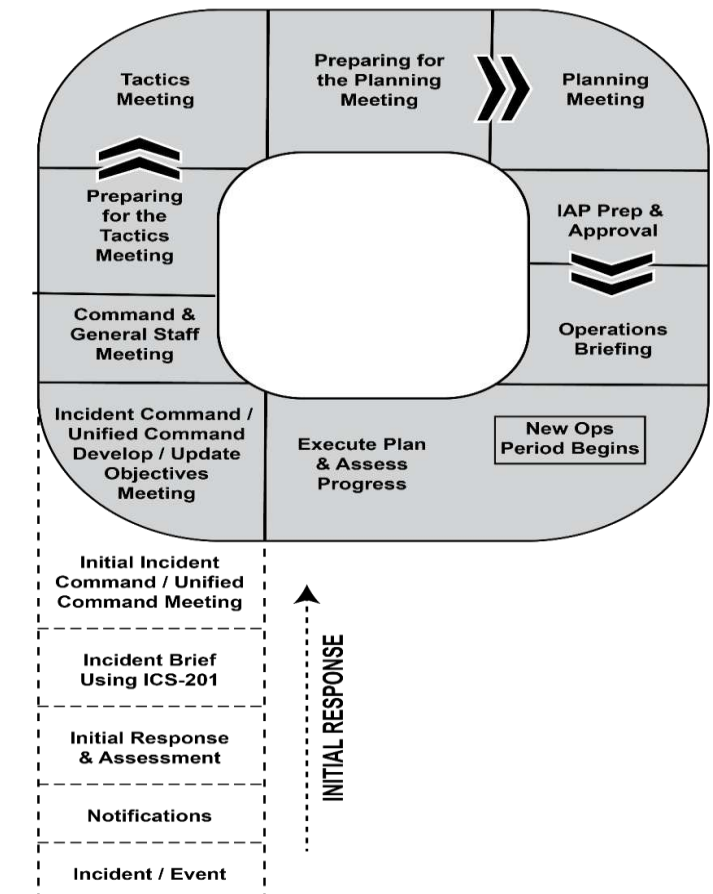

1.4 Step 1 – Situation Assessment

1.4.1 British Columbia Incident Classification Matrix

The Incident Classification Matrix is designed for use as a tool for determining the severity of an incident. Instructions: To classify an incident, start at the top of the consequence ranking section and move down until you check one box. Then repeat for the probability ranking to determine the incident classification.

Spill Reporting Criteria

Permit holders must consult the BC Environmental Management Act, Spill Reporting Regulation, for reporting thresholds and requirements.

Consequence Ranking

Rank	Probability of Escalation or Control (one of the following)
4	<input type="checkbox"/> Major on-site equipment or infrastructure loss <input type="checkbox"/> Persistent and malicious equipment damage or tampering <input type="checkbox"/> Liquid spill or gas release beyond site, affecting persons, property or the environment
3	<input type="checkbox"/> Major on-site equipment failure <input type="checkbox"/> Malicious equipment damage or tampering <input type="checkbox"/> Liquid spill or gas release beyond site, potentially affecting persons, property or the environment
2	<input type="checkbox"/> Major on-site equipment damage <input type="checkbox"/> Kick size in excess of 3 cubic metres or shut-in casing pressure in excess of 1,000 kPa <input type="checkbox"/> Persistent/multiple minor vandalism or security incidents <input type="checkbox"/> Liquid spill or gas release on site or potentially beyond site, not affecting persons, property or the environment
1	<input type="checkbox"/> Moderate on-site equipment damage <input type="checkbox"/> Minor vandalism or facility security incident <input type="checkbox"/> Liquid spill or gas release confined to site
0	<input type="checkbox"/> No consequential impacts

Probability Ranking

Rank	Probability of Escalation or Control (one of the following)
4	<input type="checkbox"/> Uncontrolled, control unlikely in near term
3	<input type="checkbox"/> Escalation possible; under or imminent control
2	<input type="checkbox"/> Escalation unlikely; controlled or likely imminent control
1	<input type="checkbox"/> Escalation highly unlikely; controlled or imminent control
0	<input type="checkbox"/> Will not escalate; no hazard; no monitoring required

Incident Risk Score and Classification

Consequence ____ + Probability ____ = Risk Score ____

(this must be completed)

Notification Requirements

Risk Score	Notification Requirement
Minor (1-2)	Notify the regulator within 24 hours of becoming aware of an incident; using the online reporting tool. Minor incidents that involve a spill must also be reported to EMCR (1-800-663-3456).
Level 1 (3-4)	Notify the regulator within one hour of becoming aware of the incident; (EMCR: 1-800-663-3456)
Level 2 (5-6)	
Level 3 (7-8)	

This matrix should be attached upon submission of an incident via the online reporting tool.

Other Reportable Incidents Requirements

The Incident Classification Matrix is designed to assist permit holders in determining which incidents must be reported. Some incidents may not meet the criteria outlined in the matrix but still require notification to the regulator as a minor incident. These include the following:

- Major damage to oil and gas roads
- Pipeline incidents such as spills during construction or exposed pipeline
- Seismic events M4 or above

Incident Response

Incident Classification				
Responses	Alert	Level 1 Emergency	Level 2 Emergency	Level 3 Emergency
Communications				
Internal	Discretionary, depending on licensee policy.	Notification of off-site management.	Notification of off-site management.	Notification of off-site management.
External Public	Courtesy, at licensee discretion.	Mandatory for individuals who have requested notification within the EPZ.	Planned and instructive in accordance with the specific ERP.	Planned and instructive in accordance with the specific ERP.
Media	Reactive as required.	Reactive as required.	Proactive media management to local or regional interest.	Proactive media management to national interest.
Government	Reactive, as required. Notify the AER 24-Hour Response Line if public or media is contacted.	Notify the AER 24-Hour Response Line. Call local authority and AHS if public or media is contacted.	Notify the AER 24-Hour Response Line, local authority and AHS.	Notify the AER 24-Hour Response Line, local authority, and AHS.
Actions				
Internal	On site as required by licensee.	On site as required by licensee. Initial response undertaken in accordance with the specific or corporate level ERP.	Predetermined public safety actions are under way. Corporate management team alerted and may be appropriately engaged to support on-site responders.	Full implementation of incident management system.
External	On site as required by licensee.	On site as required by licensee.	Potential for multi-agency (operator, municipal, provincial or federal) response.	Immediate multi-agency (operator, municipal, provincial or federal) response.
Resources				
Internal	Immediate and local. No additional personnel required.	Establish what resources would be required.	Limited supplemental resources or personnel required.	Significant incremental resources required.
External	None.	Begin to establish resources that may be required.	Possible assistance from government agencies and external support services required.	Assistance from government agencies and external support services required.

1.5 Step 2 – Establish Command

The Incident Commander (IC) is responsible for the overall management of the incident. The role will be assigned to the individual who has the highest qualifications and experience.

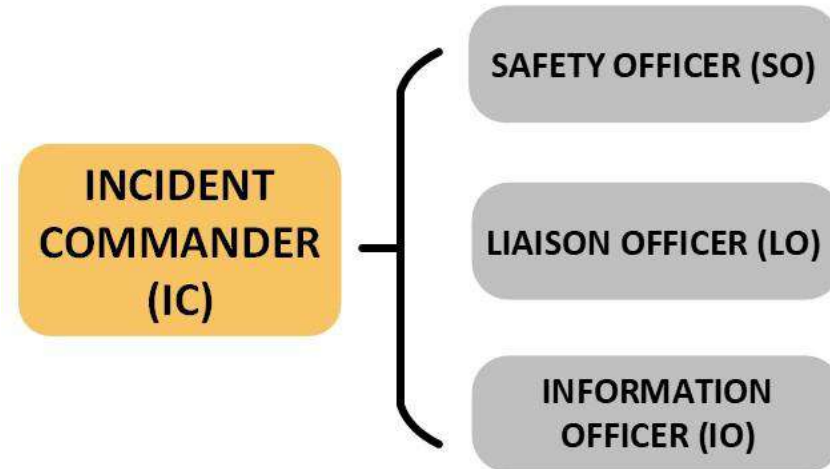

*Determine if other roles are needed to establish the field response team – Consider site and scale
Deputy Incident Commander can be assigned for larger scaled incidents*

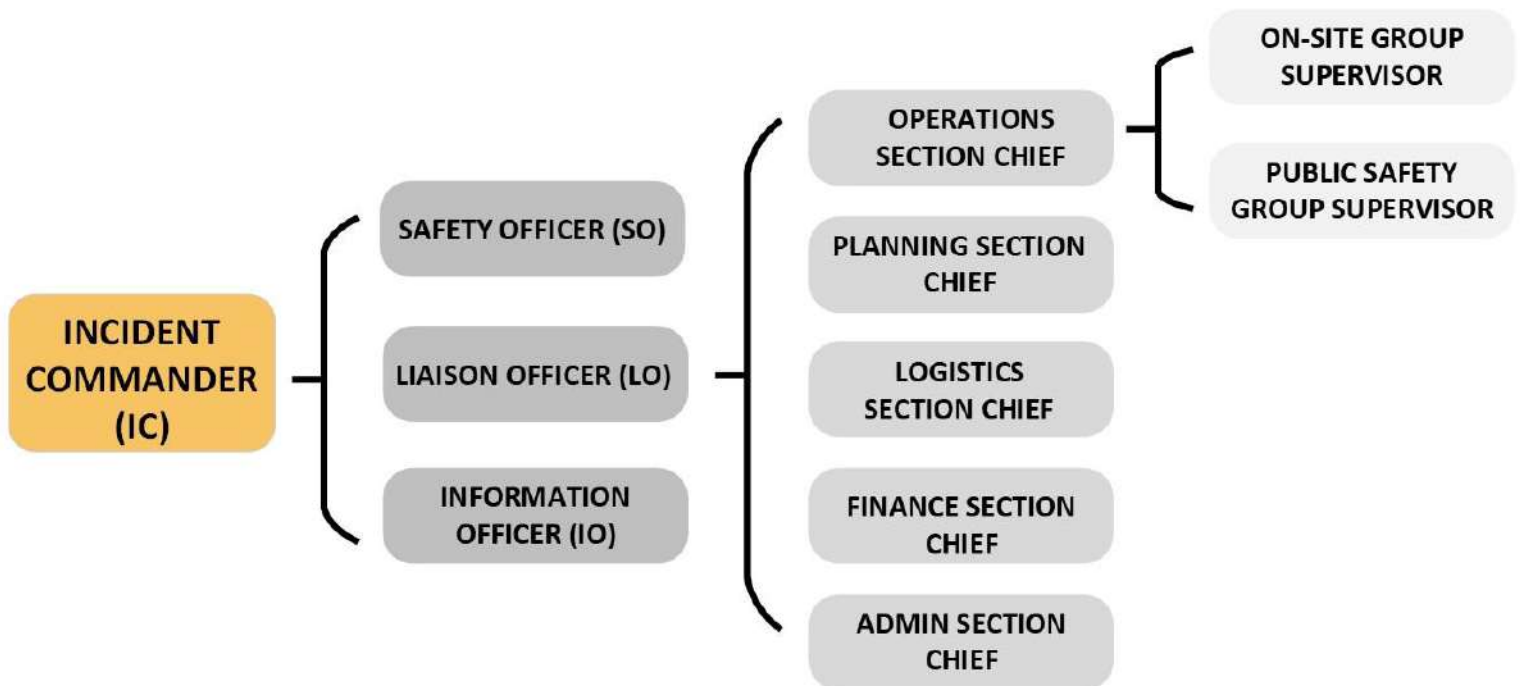

1.6 Step 3 – Coordinate Internal Notification

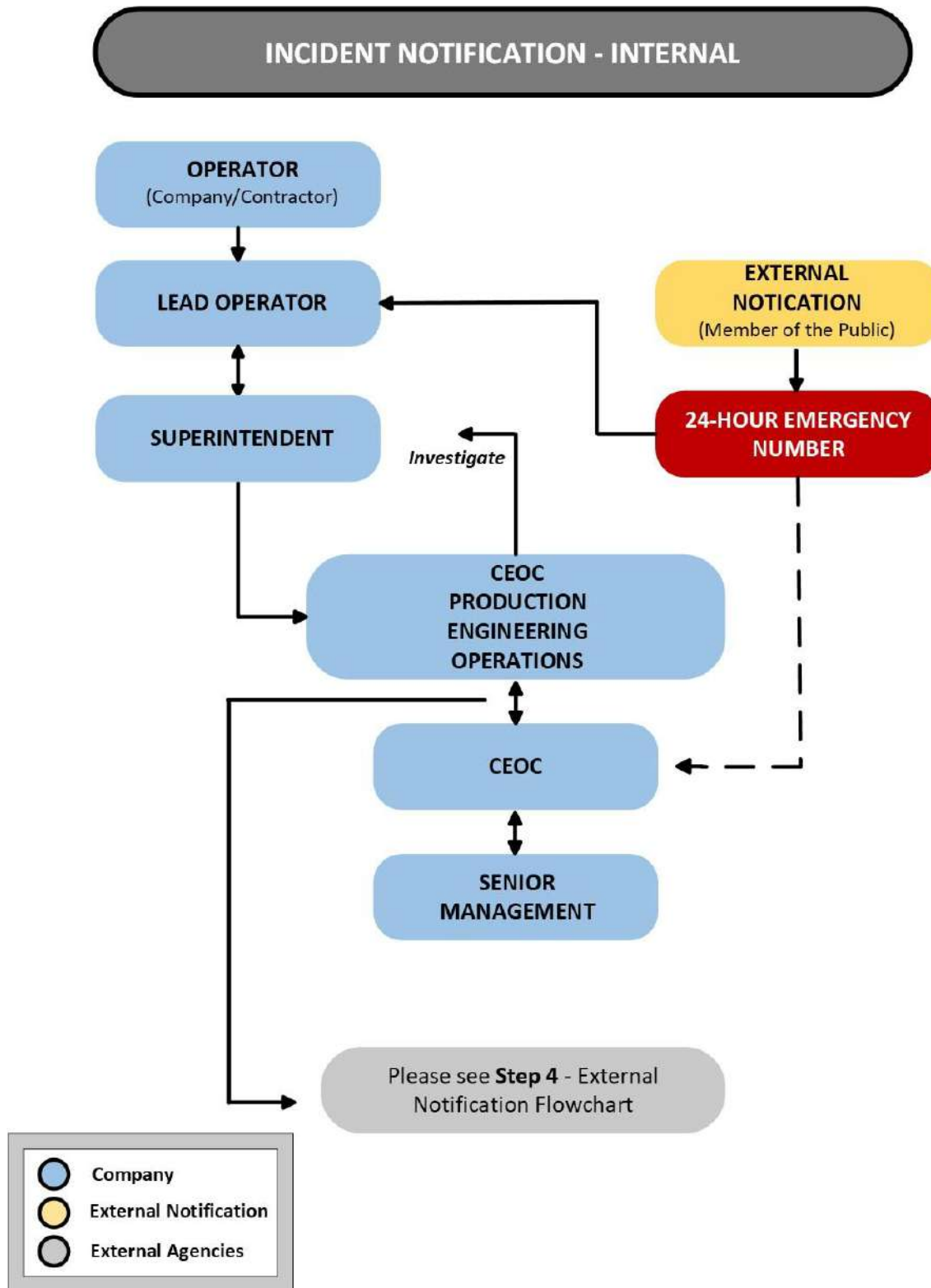

1.7 Step 4 – Undertake External Notification

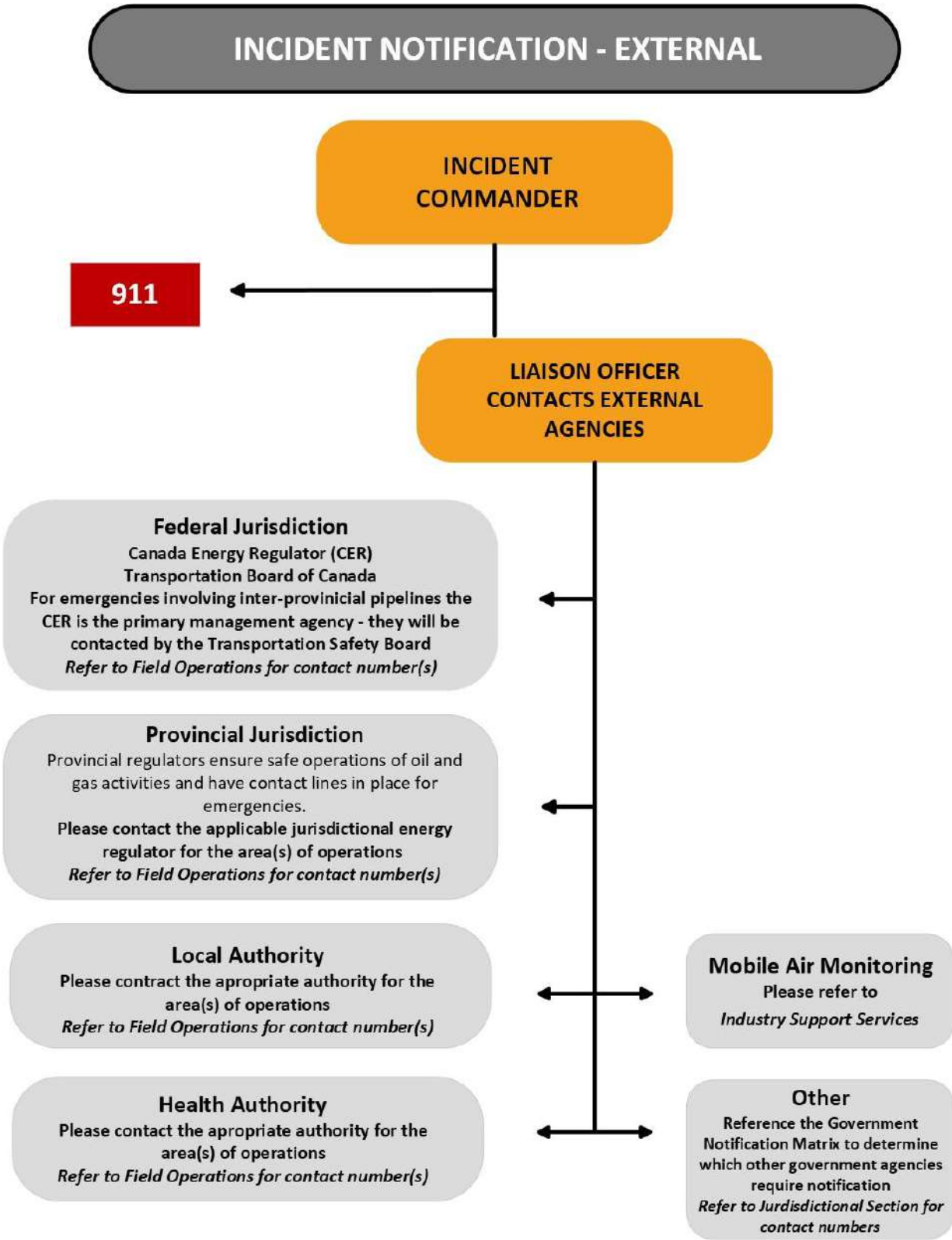

1.7.1 British Columbia Notification Requirements for Key Government Agencies and Local Resources (BC)

British Columbia

INCIDENT TYPE	AGENCY OR RESOURCE	Initial Responders			Lead Agencies				Other Government Contacts					Support Services
		Ambulance Services	Local Fire Department or Industrial Fire Service	Police	EMCR	BCER	Ministry of Environment & Climate Change Strategy	Local Authorities	Local Health Authority ¹	WorkSafe BC	Technical Safety BC	Ministry of Forests, Lands, Natural Resource Operations & Rural Development ²	Ministry of Transportation and Transit ³	Electrical Provider
Sour Gas Release				✓	✓	✓	✓	✓			✓	✓		
Sweet Combustible Gas Release				✓	✓	✓	✓	✓			✓	✓		
Spill - Unrefined Products*					✓	✓	✓	✓			✓	✓		✓
Spill - Refined Products*					✓	✓	✓	✓			✓	✓		✓
Major Release of a Hazardous Substance				✓	✓	✓	✓	✓	✓		✓	✓		✓
Trucking/Motor Vehicle Incident				✓	✓	✓	✓					✓		
Serious Injury or Fatality (including sour gas exposure)		✓	✓	✓	✓				✓					
Fire/Explosion			✓ ⁴	✓	✓		✓	✓	✓	✓	✓	✓		
Boiling Liquid Vapour Explosion - BLEVE				✓	✓		✓	✓	✓		✓	✓		
Pressure Vessel or Piping Incident					✓	✓						✓		
Electrical Incident					✓						✓		✓	
Security Incident				✓	✓	✓						✓		

✓ Mandatory contact * Refer to the British Columbia Petroleum Industry Release Reporting Requirements chart included in the ERP.

- ¹ Contact the Local Health Authority if the incident has the potential to impact public health.
- ² Contact BC Ministry of Forests, Lands, Natural Resource Operations & Rural Development for any event that could affect forested areas.
- ³ Contact BC Ministry of Transportation and Transit or the RCMP if the emergency affects a highway designated by 1, 2, or 3 digits (e.g. Hwy 2, Hwy 47, Hwy 837).
- ⁴ Contact local Fire Department or Industrial Fire Service in a BLEVE scenario to be a backup to ERAC.

Federal

INCIDENT TYPE	AGENCY OR RESOURCE	Initial Responders	Lead Agencies	Other Government Contacts					Support Services	
		RCMP	CER ¹	Transportation Safety Board (TSB)	Environment and Climate Change Canada ²	Indian Oil and Gas Canada ⁴	DFO	CANUTEC ³	ERAC - Emergency Response Assistance Canada ⁵	NAV Canada
Sour Gas Release		✓	✓		✓	✓	✓			✓
Sweet Combustible Gas Release		✓	✓		✓	✓	✓			✓
Spill - Unrefined Products*			✓		✓	✓	✓	✓		
Spill - Refined Products*			✓		✓	✓	✓	✓		
Trucking/Motor Vehicle Incident		✓			✓		✓	✓		
Marine, pipeline, rail and air modes				✓						
Serious Injury or Fatality (including sour gas exposure)		✓	✓			✓				
Fire/Explosion		✓	✓		✓	✓				✓
Boiling Liquid Vapour Explosion - BLEVE			✓					✓		
Pressure Vessel or Piping Incident			✓		✓			✓		
Electrical Incident			✓		✓					
Security Incident		✓	✓							

- ✓ Mandatory contact
- ¹ Contact the Canada Energy Regulator (via the Transportation Safety Board of Canada) for emergencies involving CER regulated sites and inter-provincial pipelines.
- ² Contact Environment and Climate Change Canada for incidents involving spills on first nation's lands, in National Parks, into river or lake systems containing fish or onto railway rights-of-way.
- ³ Contact the Canadian Transport Emergency Centre (CANUTEC) if information is required about handling procedures for toxic material releases.
- ⁴ Contact Indian Oil and Gas Canada for incidents effecting First Nation reserves and Metis settlements.
- ⁵ Contact ERAC for emergencies related to specific ERAP products for vessels containing over 450 liters or greater by road, rail and stationary tank.

Initial Notification Process

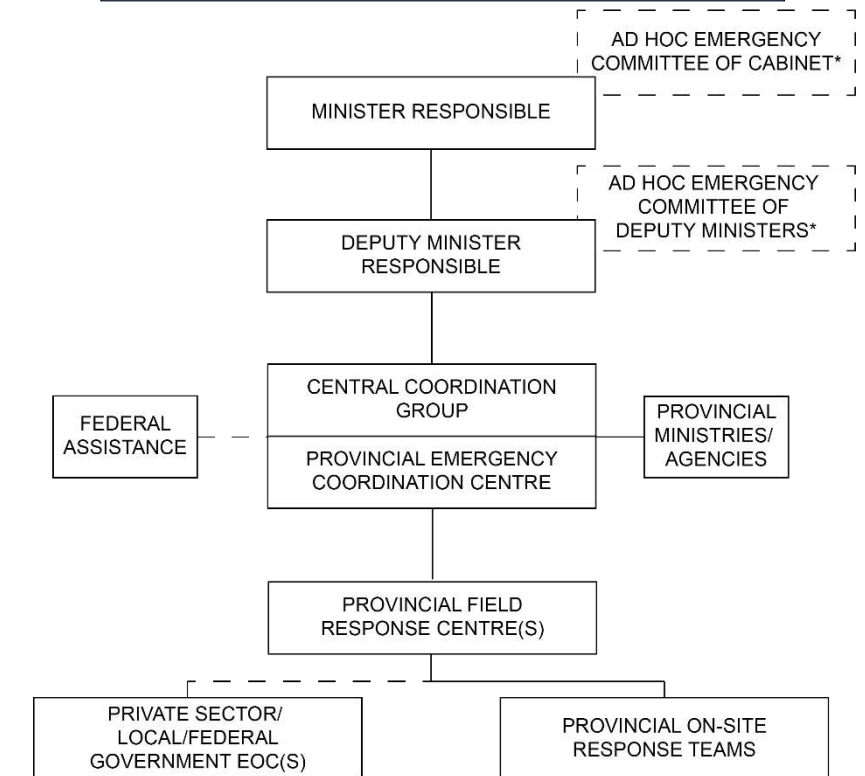

*AD HOC COMMITTEE THAT MAY BE FORMED IN THE EVENT OF A SEVERE EMERGENCY OR CATASTROPHIC EVENT.

1.7.2 Alberta Notification Requirements for Key Government Agencies and Local Resources (AB)

INCIDENT TYPE	AGENCY OR RESOURCE	Initial Responders			Lead Agencies				Other Government Contacts					Support Services	
		Ambulance Services	Local Fire Department or Industrial Fire Service	Police/ RCMP ²	AER Energy/Environmental Emergency and Operations Complaint Line	EPA	Local Authorities (i.e. urban centres, MDs, and first nations reserves)	AHS - Alberta Health Services ³	Alberta Occupational Health and Safety	Workers' Compensation Board	AEMA - Alberta Emergency Management Agency	ABSA - Alberta Boilers Association	Alberta Agriculture and Forestry ⁴	Alberta Safety Services - Electrical Branch	Alberta Transportation EDGE
Sour Gas Release				✓	✓	✓	✓	✓		✓		✓		✓	
Sweet Combustible Gas Release				✓	✓	✓	✓	✓		✓		✓		✓	
Spill - Unrefined Products*					✓	✓	✓	✓		✓		✓		✓	✓
Spill - Refined Products*					✓	✓	✓	✓		✓		✓		✓	✓
Trucking/Motor Vehicle Incident		✓	✓	✓	✓	✓	✓	✓						✓	
Serious Injury or Fatality (including sour gas exposure)		✓		✓	✓		✓	✓	✓						
Fire/Explosion			✓	✓	✓	✓	✓	✓		✓		✓		✓	
Boiling Liquid Vapour Explosion - BLEVE			✓ ¹	✓	✓	✓	✓	✓		✓		✓		✓	
Collapse or upset of a crane, derrick or hoist Collapse or failure of any component of a building or structure								✓							
Pressure Vessel or Piping Incident					✓			✓			✓			✓	
Electrical Incident			✓		✓			✓					✓	✓	
Security Incident				✓	✓			✓						✓	

✓ Mandatory contact ✓ Contact consideration based on emergency event details.

* Refer to the Alberta Petroleum Industry Release Reporting Requirements chart included in the ERP.

- ¹ Contact Local Fire Department or Industrial Fire Service in a BLEVE scenario to be a backup to ERAC.
- ² Contact RCMP if the emergency affects a highway designated by 1, 2, or 3 digits (e.g. Hwy 2, Hwy 47, Hwy 837).
- ³ Contact Alberta Health Services (AHS) if the incident has the potential to impact public health (i.e. sour gas release impacting stakeholders.)
- ⁴ Contact Alberta Agriculture and Forestry for any event that could affect forested areas.
- ⁵ Alberta Transportation EDGE is the first call for all transportation related spills/incidents.

INCIDENT TYPE	AGENCY OR RESOURCE	Initial Responders	Lead Agencies	Other Government Contacts					Support Services	
		RCMP	CER ¹	Transportation Safety Board (TSB)	Environment and Climate Change Canada ²	Indian Oil and Gas Canada ³	DFO ⁴	CANUTEC ⁵	ERAC - Emergency Response Assistance Canada ⁶	NAV Canada
Sour Gas Release		✓	✓	✓	✓	✓				✓
Sweet Combustible Gas Release		✓	✓	✓	✓	✓				✓
Spill - Unrefined Products*			✓	✓	✓	✓	✓	✓		
Spill - Refined Products*			✓	✓	✓	✓	✓	✓		
Trucking/Motor Vehicle Incident		✓		✓	✓		✓	✓		
Marine, pipeline, rail and air modes				✓			✓			
Serious Injury or Fatality (including sour gas exposure)		✓	✓	✓		✓				
Fire/Explosion		✓	✓	✓	✓	✓				✓
Boiling Liquid Vapour Explosion - BLEVE			✓					✓		
Pressure Vessel or Piping Incident			✓		✓		✓	✓		
Electrical Incident			✓		✓					
Security Incident		✓	✓	✓						

✓ Mandatory contact ✓ Contact consideration based on emergency event details.

- ¹ Contact the Canada Energy Regulator (via the Transportation Safety Board of Canada) for emergencies involving CER regulated sites and inter-provincial pipelines.
- ² Contact Environment and Climate Change Canada for incidents involving spills on First Nation's lands, in National Parks, into river or lake systems containing fish or onto railway rights-of-way.
- ³ Contact Indian Oil and Gas Canada for incidents affecting First Nation reserves and Metis settlements.
- ⁴ Contact the DFO to report any spill that occurs in or around fresh, marine, or fish bearing waters.
- ⁵ Contact the Canadian Transport Emergency Centre (CANUTEC) if information is required about handling procedures for toxic material releases.
- ⁶ Contact ERAC for emergencies related to specific ERAP products for vessels containing over 450 liters or greater by road, rail and stationary tank.

Initial Notification Process

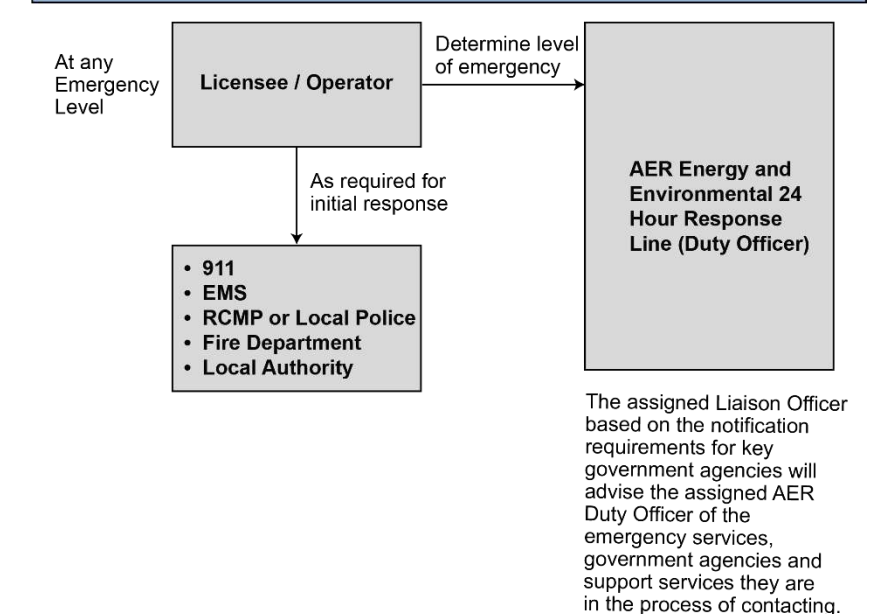

1.8 Step 5 – Run Briefing

Refer to the Forms Section for ICS 201(Incident Briefing Form), ICS 202 (Incident Objectives)

Briefing Sessions

Effective briefing sessions are:

- An essential element of good supervision and incident management
- Intended to pass along vital information required for the completion of incident response actions

Typically, these briefings are concise and do not include long discussions or complex decision making. Rather, they allow incident managers and supervisors to communicate specific information and expectations for the upcoming work period and to answer questions.

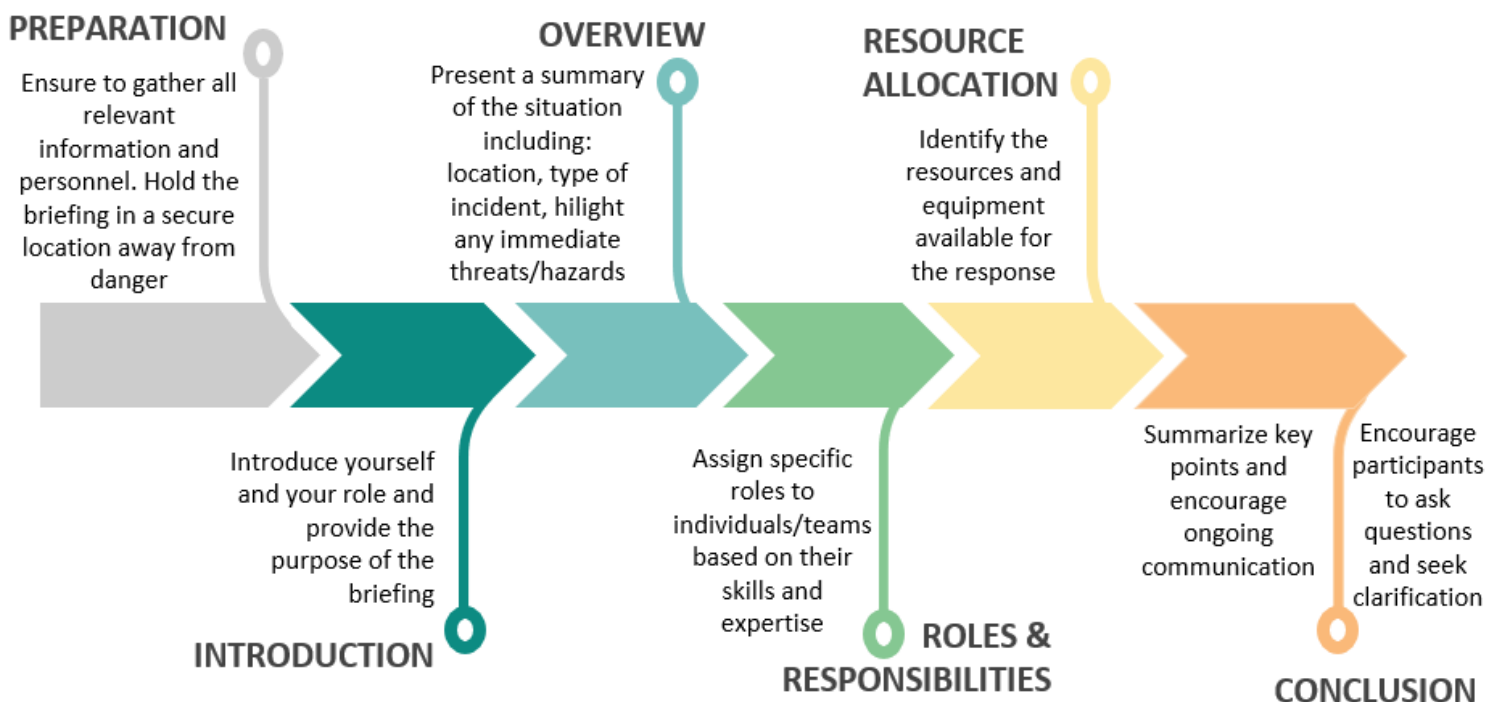

1.8.1 Incident Priorities Chart

INCIDENT PRIORITIES					
PEAR	PROBLEM	OBJECTIVE	STRATEGY	TACTICS	TIME FRAME
<i>People Environment Assets Reputation</i>	<i>A problem is a threat or a potential threat to any, or all priorities</i>	<i>An objective is the simplest solution to the problem facing your priority(s)</i>	<i>Strategies are the way, or the ways that you achieve your objective</i>	<i>Tactics are the resources (people/equipment) required to do the job</i>	<i>Estimated time to complete this objective</i>
Operational Period:				To:	From:

1.9 Step 6 – Ensure Public Safety

1.9.1 Public Protection Measures Flowchart (BC)

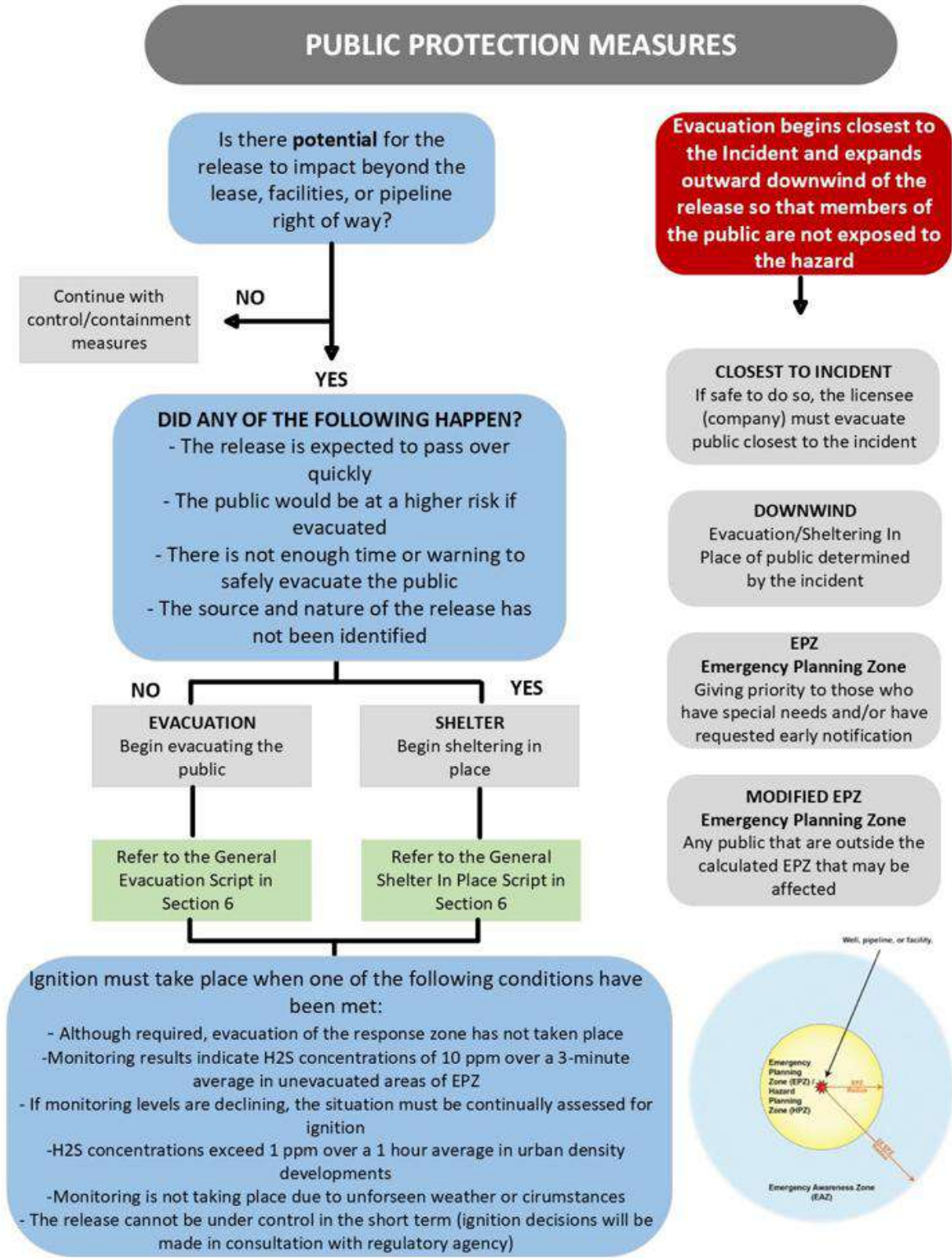

1.9.2 Public Protection Measures Flowchart (AB)

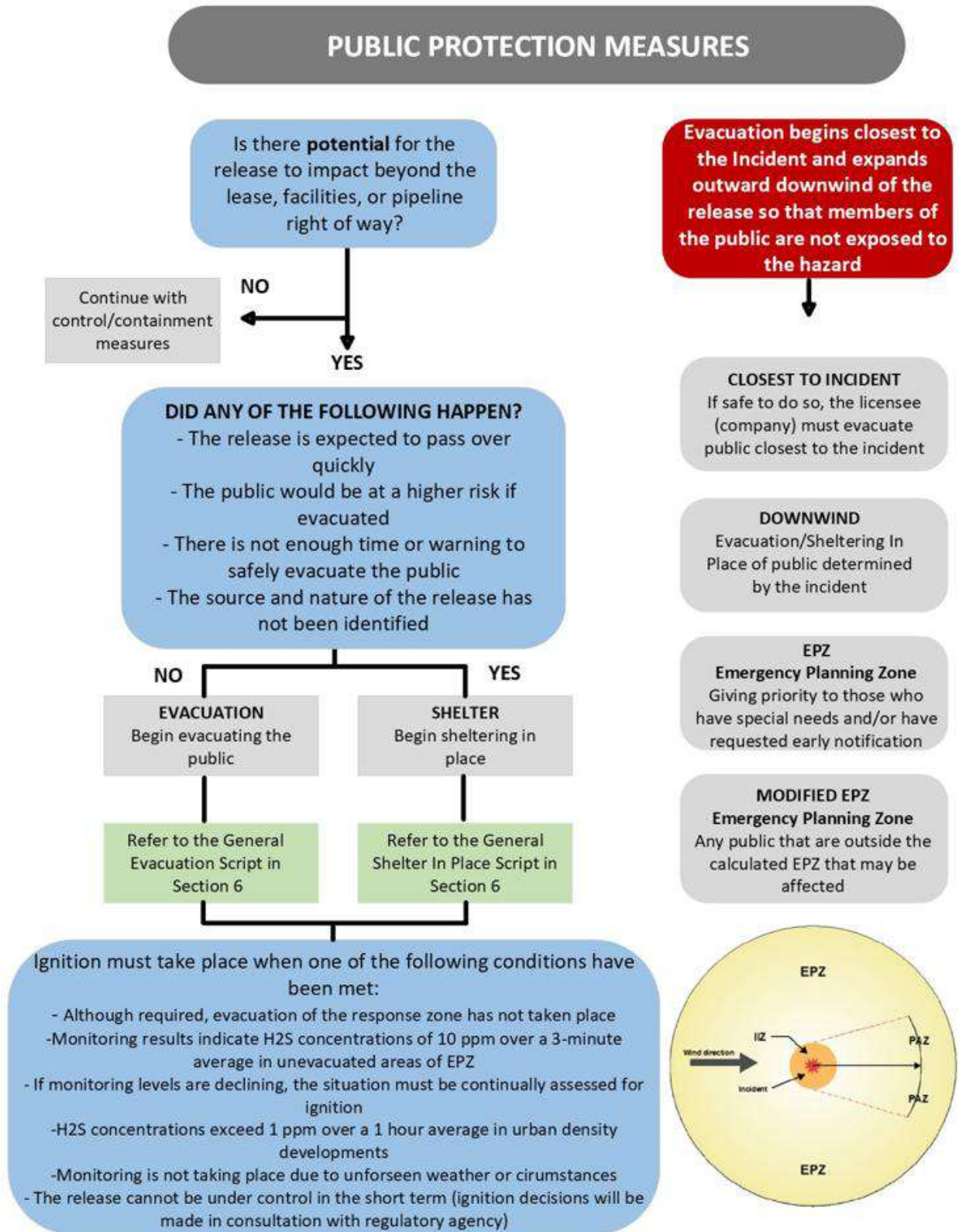

2.0 CEOC TELEPHONE LIST / POLICY STATEMENT**2.1 Corporate Contact List**

NorthRiver Midstream Inc.			
24-Hour Emergency Number			
1-844-667-8477			
[REDACTED]			
[REDACTED]			
Name	Position	Office	Cell
[REDACTED]	[REDACTED]	[REDACTED]	[REDACTED]
[REDACTED]	[REDACTED]	[REDACTED]	[REDACTED]
[REDACTED]	[REDACTED]	[REDACTED]	[REDACTED]
[REDACTED]	[REDACTED]	[REDACTED]	[REDACTED]
[REDACTED]	[REDACTED]	[REDACTED]	[REDACTED]

2.2 Emergency Management Policy Statement

NorthRiver Midstream is committed to conducting all of its business operations activities with maximum regard to the protection and safety of its employees, contractors and other on-site personnel, the community, the public, and the environment in which it operates.

It will accomplish this goal by:

- Preparing and maintaining up to date contingency plans and emergency response procedures to guide company personnel and others in responding to an emergency incident QUICKLY, SAFELY and EFFECTIVELY.
- Complying fully with all federal, provincial and municipal laws and regulations when responding to an emergency incident.
- Responding quickly, safely and effectively to any emergency for which it is responsible and providing information and assistance to others responding to any incident involving its products.
- Providing clear, accurate and timely information to the public about any incident which may place the community or the environment at risk.
- Ensuring its employees receive appropriate training in safety and emergency response procedures.
- Ensuring local responders receive appropriate training in safety and emergency response procedures.
- Setting and achieving high standards of operational integrity and incident prevention in all aspects of its operations.

Response Priorities

The response procedures outlined in this plan and all response actions taken by NorthRiver Midstream personnel in an emergency response will be carried out in the following order with the listed overall priorities:

- **PROTECTION OF LIFE** – including responders, workers, employees, contractors and the public.
- **PROTECTION OF THE ENVIRONMENT** – including sensitive land or marine ecological resources.
- **PROTECTION OF PROPERTY** – including private and public property used for residential, commercial, and/or recreational purposes including drinking water and other amenities.

3.0 SITE INCIDENT COMMAND STRUCTURE - ROLES AND RESPONSIBILITIES

3.1 Site Command Chart

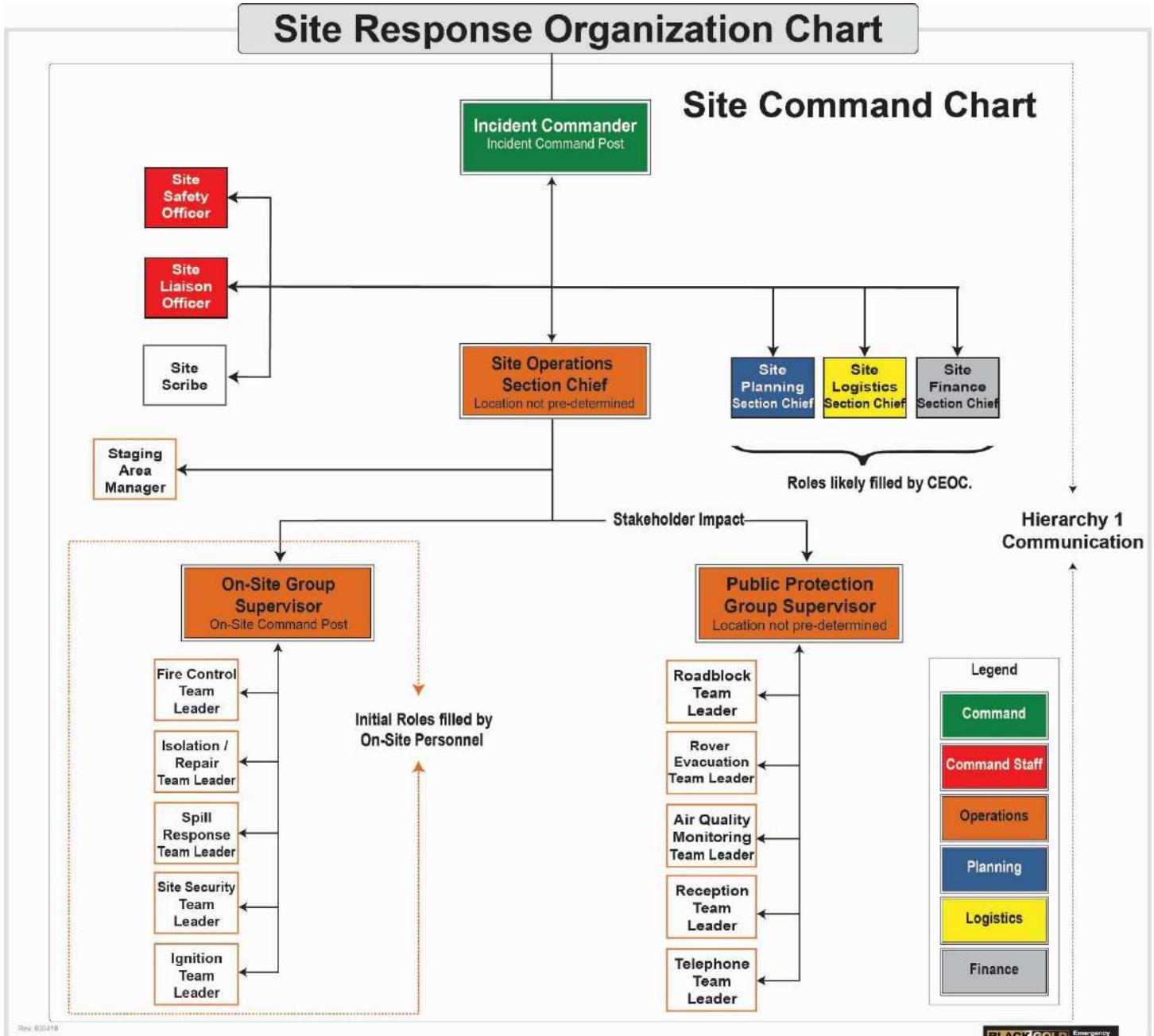

3.2 First Responder

The First Responder is the first person at the incident location. If properly trained and qualified, the First Responder will be responsible for the following checklist.

Location	On-Site
Evacuate (Protect yourself)	<input type="checkbox"/> Remain calm. <input type="checkbox"/> Get to a safe area away from the hazard. <input type="checkbox"/> Direct others to a safe area.
Sound the Alarm	<input type="checkbox"/> Alert other personnel on-site. <input type="checkbox"/> Call for help (your supervisor or control room, as appropriate). <input type="checkbox"/> Activate mutual aid and emergency services, as required.
Assess Incident	<input type="checkbox"/> Resist the urge to rush in, others cannot be helped if you are injured. <input type="checkbox"/> Gather at muster stations and conduct a head count. <input type="checkbox"/> Consider wind direction. <input type="checkbox"/> Identify exposure to environments that may be toxic, flammable, explosive, or otherwise harmful. <input type="checkbox"/> Ensure personnel understand hazards and control actions.
Protect	<input type="checkbox"/> Assume on-site ICS duties until relieved, refer to Incident Commander checklist. <input type="checkbox"/> Take action to shutdown, isolate, control, or contain incident. <input type="checkbox"/> Don personal protective equipment. <input type="checkbox"/> Control entry into hazardous area. <input type="checkbox"/> Secure the area. <input type="checkbox"/> Release non-essential on-site personnel.
Rescue Operations	Only if safe to do so: <input type="checkbox"/> Rescue victim to safe area.
Medical Aid	<input type="checkbox"/> Revive victim. <input type="checkbox"/> Administer first aid, maintain ongoing care and confirm emergency services have been dispatched.
Continue Response	<input type="checkbox"/> Continue to implement ICS response actions.

Forms	
<input type="checkbox"/>	ICS 214 – Activity Log

3.3 Incident Commander

The Incident Commander assumes responsibility for the implementation and management of emergency response procedures at the incident site. Even if other functions are not filled, an Incident Commander will always be designated. The Incident Commander's key responsibilities are worker/responder safety, public safety, and control and containment.

The Incident Commander role should be assigned to the most experienced company supervisor or representative near the incident site. The Incident Commander has the responsibility to establish the Incident Command Post and manage the implementation of a safe and effective tactical response.

The Incident Commander is responsible for all response functions until he/she delegates those response activities.

INCIDENT COMMANDER	
Location	
	Incident Command Post.
Confers With	
<input type="checkbox"/>	CEOC Operations Chief.
Gives Direction To	
<input type="checkbox"/>	Site Operations Section Chief.
<input type="checkbox"/>	Site Planning Section Chief.
<input type="checkbox"/>	Site Logistics Section Chief.
<input type="checkbox"/>	Finance Section Chief.
<input type="checkbox"/>	Site Safety Officer.
<input type="checkbox"/>	Site Liaison Officer.
<input type="checkbox"/>	Site Scribe.

INCIDENT COMMANDER	
Situation Assessment	
<input type="checkbox"/>	Consider evacuating non-essential personnel to safety and place them on standby to fill positions as required.
<input type="checkbox"/>	Dispatch trained and appropriately equipped personnel (preferably in pairs) to investigate.
<input type="checkbox"/>	If the situation assessment confirms that company assets are involved, activate Incident Command Post and establish Incident Command.
<input type="checkbox"/>	If the incident involves another company's asset, ensure that their personnel are notified. Maintain contact with the responsible operating company until they arrive on scene.
<input type="checkbox"/>	Ensure the re-contact of the person who reported the incident and ensure they are advised of the result of the situation assessment.
<input type="checkbox"/>	Notify appropriate company personnel.
<input type="checkbox"/>	Assess the situation and, using the appropriate matrix for classifying incidents, determine the level of emergency.
Alert/Minor	
<input type="checkbox"/>	Ensure first aid and transport for any injured personnel is initiated as required. Take a head count and ensure personnel are accountability record is maintained for the duration of the incident.
<input type="checkbox"/>	Document all activities utilizing the ICS 214 – Activity Log.
<input type="checkbox"/>	Develop an initial response strategy that adheres to PEAR (protect people, environment, assets and reputation) emergency response priorities.
<input type="checkbox"/>	Based on initial information, identify the problems facing PEAR priorities and the objectives to eliminate the problems. Identify the appropriate tactics/strategies and develop and implement the initial Incident Action Plan.
<input type="checkbox"/>	Establish contact and method of communications with the CEOC Operations Chief.
<input type="checkbox"/>	Schedule regular briefings with the CEOC Operations Chief.
<input type="checkbox"/>	Evaluate resource requirements and advise CEOC Operations Chief.
<input type="checkbox"/>	For an incident that is not impacting public safety, consider public notification as a courtesy.
<input type="checkbox"/>	Assess the situation using the appropriate matrix for classifying incidents. Reassess and determine the Level of Emergency. Consider conferring with the CEOC Operations Chief.
<input type="checkbox"/>	Ensure Regulatory Authority notification according to the applicable requirements. If any member of the public or media is aware of the situation, notify the regulator.
<input type="checkbox"/>	Refer to the Notification Requirements for Key Government Agencies and Resources in the Jurisdictional section of this document.
Level 1	
<input type="checkbox"/>	Continue with previous actions.
<input type="checkbox"/>	Appoint a scribe(s) as required.
<input type="checkbox"/>	Determine the need for Site Planning Section Chief, Site Logistics Section Chief, and Finance/Admin Section Chief and activate as required.
<input type="checkbox"/>	Facilitate incident briefing meeting with Section Chiefs. Re-evaluate information and revisit, the current problems facing PEAR priorities and the objectives to eliminate the problems. Re-evaluate the appropriate tactics and strategies and revise the Incident Action Plan accordingly. Communicate any revised plans between activated command posts.
<input type="checkbox"/>	Ensure on site personnel have taken steps to protect themselves and any responders arriving at the site and have taken steps to control the incident (e.g. shutdown, isolate, depressurize) to protect the property.
<input type="checkbox"/>	Ensure public impacts are assessed and strategies for public protection are discussed and developed.
<input type="checkbox"/>	Ensure Environmental impacts are assessed and strategies for environmental protection are developed.
<input type="checkbox"/>	Providing public and environmental impacts are being addressed, consider impacts to assets and develop strategies to protect the company assets.
<input type="checkbox"/>	Upon completion of Incident Action Plan, identify safety hazards and immediate safety actions to be taken to protect against the hazards. Appoint Site Safety Officer if required. Develop safety message in preparation distribution of Incident Action Plans.
<input type="checkbox"/>	Determine the Operational Period.
<input type="checkbox"/>	Complete the ICS 201 – Incident Briefing Form.

INCIDENT COMMANDER

INCIDENT COMMANDER		
INCIDENT COMMANDER	<input type="checkbox"/> Facilitate Command and General Staff Meeting, as required. Ensure resources, personnel and equipment required are communicated and requested to accomplish the objectives defined. Present safety message.	
	<input type="checkbox"/> Immediately ensure any suspected threats of violence, sabotage or terrorism are reported.	
	<input type="checkbox"/> Ensure worker exposures exceeding allowable limits are reported.	
	<input type="checkbox"/> Ensure security at the scene and restrict access to authorized personnel only.	
	<input type="checkbox"/> Ensure on-site environmental monitoring is initiated.	
	<input type="checkbox"/> Establish an Incident Command Post and communications with other Command Centres. Logistics will support with facilities and communications as needed.	
	<input type="checkbox"/> Ensure the boundaries of the response zones are defined and identified on the area map.	
	<input type="checkbox"/> Ensure that the Site Operations Section Chief identifies roadblock locations and evaluates how many members of the public could be inside the response zones.	
	<input type="checkbox"/> Ensure the appropriate public protection measure and notification script is identified. Initiate stakeholder notification within the incident EPZ. This includes establishment of a Reception Centre if required, transient survey of the area, dispatch of Mobile Air Monitoring Unit to the area as required.	
	<input type="checkbox"/> For an incident with the potential of odours, smoke or hazardous airborne release ensure monitoring at nearest downwind occupied location.	
	<input type="checkbox"/> Discuss actions, media requirements, resource requirements and conditions with CEOC Operations Chief.	
	<input type="checkbox"/> Assign roles to personnel as appropriate for the size and complexity of the incident.	
	<input type="checkbox"/> Ensure the notification of police in the event of an industrial fatality or motor vehicle incident.	
	<input type="checkbox"/> If the incident involves a pressure vessel, ensure the notification to the designated Company Chief Inspector.	
	<input type="checkbox"/> For sour gas events, ensure appropriate safety equipment, ignition equipment and environmental monitoring equipment is readily available or dispatched as required.	
	<input type="checkbox"/> Assess the situation, and using the appropriate matrix for classifying incidents, Reassess and determine the Level of Emergency. Confer with the CEOC Operations Chief in the event of a change	
	Level 2	
	<input type="checkbox"/> Continue with previous actions.	
	<input type="checkbox"/> The immediate focus is protection of people on site and protection of public in the Emergency Planning Zone.	
	<input type="checkbox"/> Facilitate Incident briefing Meeting with Section Chiefs. Re-evaluate information and revisit, the current problems facing PEAR priorities and the objectives to eliminate the problems. Re-evaluate the appropriate tactics and strategies and revise the Incident Action Plan accordingly. Communicate any revised plans between activated command posts	
	<input type="checkbox"/> Ensure the Site Liaison Officer communicates with the lead regulatory agency and local authority to establish a closure order (state of emergency) to allow the establishment of roadblocks and evacuation of public from the planning zone.	
	<input type="checkbox"/> Determine the potential for the incident to escalate.	
	<input type="checkbox"/> Ensure the Site Operations Section Chief has established site security and is working to address source control.	
	<input type="checkbox"/> Ensure Site Operations Section Chief establishes an appropriate staging area and Manager as required to provide resource support.	
	<input type="checkbox"/> Ensure the response zone is isolated with the set up of roadblocks.	
	<input type="checkbox"/> Establish a sign-in post/station as required.	
	<input type="checkbox"/> Ensure the evacuation and staging of non-essential personnel.	
	<input type="checkbox"/> Initiate the dispatch of first line emergency services (firefighters, police, ambulance, safety contractors, or oil spill contractors) as required to meet the objectives. Ensure support for roadblock and rover personnel.	
	<input type="checkbox"/> Ensure the dispatch of a helicopter if required to survey area, transport supplies and/or assist with control measures.	
	<input type="checkbox"/> If the emergency has the potential to require ignition, ensure a qualified Ignition Team is chosen, duties are discussed and ignition equipment is on-site.	
<input type="checkbox"/> Evaluate ignition criteria and communicate with the Site Operations Section Chief, CEOC Operations Chief and applicable Regulatory Authority regarding ignition decision.		
<input type="checkbox"/> Establish a Unified Command structure with government agencies at the Incident Command Post, if necessary.		
<input type="checkbox"/> Ensure field responders are promptly notified of any status updates.		
<input type="checkbox"/> Assess the situation, and using the appropriate matrix for classifying incidents, reassess the Level of Emergency. Confer with the CEOC Operations Chief in the event of a change.		

INCIDENT COMMANDER	
Level 3	
<input type="checkbox"/>	Continue with previous actions.
<input type="checkbox"/>	Confer with CEOC Operations Chief to discuss additional control measures.
<input type="checkbox"/>	Determine if any ignition criteria has been met.
<input type="checkbox"/>	Consult with CEOC Operations Chief and applicable Regulatory Authority, if possible. Initiate ignition procedures as required
<input type="checkbox"/>	Upon confirmation of the EPZ evacuation, ensure air monitoring is directed downwind beyond the EPZ. In coordination with the local authority determine the response steps beyond the EPZ.
<input type="checkbox"/>	Update previous contacts if there is a change of status.
Deactivation	
<input type="checkbox"/>	Consider downgrade of the emergency in consultation with the CEOC Director and the applicable Regulatory Authority. Once downgrading of the level of emergency is accepted, ensure the scene is preserved, security maintained and traffic on or off site is minimized or eliminated.
<input type="checkbox"/>	Ensure all members of the Emergency Response Team and other key participants are notified of the downgrade.
<input type="checkbox"/>	Instruct CEOC Director, Command Staff and General Staff to gather incident related documentation from their teams and ensure it is submitted to the Planning Section.
<input type="checkbox"/>	Where applicable, provide instructions on the commencement of reclamation activities following control and containment and the area has been secured.
<input type="checkbox"/>	Coordinate the removal of the impacted waste material and dispose of the waste to an approved facility.
<input type="checkbox"/>	Obtain a sufficient number of samples of the remediated site to demonstrate containment.
<input type="checkbox"/>	Ensure all appropriate government agencies are notified of the stand-down of the emergency.
<input type="checkbox"/>	Ensure any notified media are updated of the stand-down of emergency.
<input type="checkbox"/>	Ensure all affected stakeholders are notified of the stand-down of emergency.
<input type="checkbox"/>	Ensure the Site Operations Section Chief coordinates the ventilation of all residences and businesses as required and that monitoring for gas pockets continues to take place.
<input type="checkbox"/>	Ensure evacuee expenses and damage claims are collected.
<input type="checkbox"/>	Ensure post-incident reports are completed and submitted, if applicable.
<input type="checkbox"/>	Ensure all members of the emergency response team and other key participants are invited to the debriefing.
<input type="checkbox"/>	Conduct post-incident debriefing.
<input type="checkbox"/>	Assess the physical and emotional health of responders and make recommendations for Critical Incident Stress Debriefing.

INCIDENT COMMANDER

Forms	
<input type="checkbox"/>	ICS 201 – Incident Briefing
<input type="checkbox"/>	ICS 214 – Activity Log
<input type="checkbox"/>	ICS 234 – Work Analysis Matrix
<input type="checkbox"/>	Notification Record
<input type="checkbox"/>	Objectives Development Workboard
Note: A comprehensive Incident Action Plan should, as a minimum, include ICS Forms 201, 202, 203, and 207.	

3.4 Site Operations Section Chief

The Site Operations Section Chief is responsible for the direction and coordination of all incident tactical operations and resources. Initially the Site Operations Section Chief consists of those few resources first assigned to an incident (these resources will initially report directly to the Incident Commander until the Site Operations Section Chief is assigned).

SITE OPERATIONS SECTION CHIEF	
Location	
<input type="checkbox"/>	Location not pre-determined.
Takes Direction From	
<input type="checkbox"/>	Incident Commander.
Confers With	
<input type="checkbox"/>	Section Chiefs, if applicable.
<input type="checkbox"/>	Site Safety Officer
<input type="checkbox"/>	CEOC Information Officer
Gives Direction To	
<input type="checkbox"/>	On-Site Group Supervisor.
<input type="checkbox"/>	Public Protection Group Supervisor.
<input type="checkbox"/>	Staging Area Manager.
Alert/Minor	
<input type="checkbox"/>	Document all activities utilizing the ICS 214 – Activity Log.
<input type="checkbox"/>	Establish method of communications with the Incident Commander and provide support as required.
<input type="checkbox"/>	Schedule regular briefings with the Incident Commander.
<input type="checkbox"/>	Designate Public Protection Group Supervisor and On-Site Group Supervisor, as required.
Level 1	
<input type="checkbox"/>	Continue with previous actions.
<input type="checkbox"/>	Instruct On-Site Group Supervisor to establish the On-Site Command Post.
<input type="checkbox"/>	Facilitate Tactics Meeting with the Site Safety Officer, Site Logistics Section Chief, and Site Admin/Finance Section Chief. Discuss how the objectives will be met. Review strategy and required resources to satisfy the objectives.
<input type="checkbox"/>	Prepare the ICS 215 – Operational Planning Worksheet with assistance from the Site Safety Officer and Site Logistics Section Chief or CEOC Logistics Chief. Document all decisions made during the Tactics Meeting concerning resource assignments and needs for the next operational period. Share completed ICS 215 with all Command and General Staff.
<input type="checkbox"/>	Prepare the ICS 204 – Assignment List, obtain sign-off from the Planning Section and approval from Incident Commander prior to dissemination as part of the Incident Action Plan.
<input type="checkbox"/>	Distribute approved Incident Action Plan to the Incident Commander.
<input type="checkbox"/>	Participate in the Operations briefing.
<input type="checkbox"/>	Implement Incident Action Plan in coordination with the Incident Commander, On-Site Group Supervisor, Public Protection Group Supervisor, and Staging Area Manager.
<input type="checkbox"/>	Identify EPZ boundaries.
<input type="checkbox"/>	Evaluate how many stakeholders are inside the EPZ. Account for residents, businesses, First Nations persons, trappers, guide/outfitters, grazing lessees, transients, highways, waterways, railroads and public facilities.
<input type="checkbox"/>	In coordination with the Incident Commander and Public Protection Group Supervisor, determine applicable public protection method, public notification/evacuation, EPZ isolation (roadblock), air quality monitoring and Reception Centre activation strategy.
<input type="checkbox"/>	Review strategy with Site Safety Officer and instruct the development of safe protocols, procedures, and messaging for each component of the Public Protection Strategy and On-Site response.
<input type="checkbox"/>	Direct Public Protection Group Supervisor to identify and, if needed, to acquire appropriate resources to implement and initiate Public Protection Strategy
<input type="checkbox"/>	Determine what methods of communication are available to the Team Directors and Team Leaders and schedule regular briefings.
<input type="checkbox"/>	Ensure the Public Protection Group Supervisor deploys required voluntary evacuation assistance to residents identified as having special needs.

SITE OPERATIONS SECTION CHIEF

SITE OPERATIONS SECTION CHIEF		
SITE OPERATIONS SECTION CHIEF	<input type="checkbox"/> If required, instruct the Public Protection Group Supervisor to establish a Reception Centre for any evacuated residents. Ensure appropriate public messaging and forms are available for the Reception Team.	
	<input type="checkbox"/> Review the topographical information, weather data and weather forecast information.	
	<input type="checkbox"/> Instruct the Public Protection Group Supervisor to implement the appropriate air quality monitoring strategy. (Note: ensure Air Quality Monitoring Team is taking place at the nearest downwind un-evacuated location).	
	<input type="checkbox"/> Instruct the Public Protection Group Supervisor to ready Roadblock Team and stand by. (Review maps, location of set up. kits, communications, forms appropriate scripts and review safe activation and manning protocols.)	
	<input type="checkbox"/> In coordination with the On Site Group Supervisor, assess the requirements for on-site safety supervision, personnel, equipment, and other contract services.	
	<input type="checkbox"/> Provide direction to the On-Site Group Supervisor to address on-site safety, fire control, isolation, equipment damage, repair, spill response, site security, and waste management as required.	
	<input type="checkbox"/> Assess the requirements for on-site safety supervision, personnel, equipment and other contract services.	
	<input type="checkbox"/> Coordinate with the Site Logistics Section Chief (if assigned) to obtain equipment and resources.	
	<input type="checkbox"/> Compile and display incident information.	
	<input type="checkbox"/> Ensure the assignment of roles to personnel is appropriate for the size and complexity of the incident.	
	Level 2	
	<input type="checkbox"/> Continue with previous actions.	
	<input type="checkbox"/> Direct Public Protection Group Supervisor to revisit EPZ boundaries.	
	<input type="checkbox"/> Direct Public Protection Group Supervisor to initiate Public Protection Strategies (shelter and/or evacuation procedures).	
	<input type="checkbox"/> Ensure transient surveys are completed.	
	<input type="checkbox"/> Ensure mobile environmental and/or air quality monitoring is taking place at the nearest un-evacuated downwind location.	
	<input type="checkbox"/> Ensure roadblocks are established.	
	<input type="checkbox"/> When required, dispatch a Staging Area Manager to establish and coordinate operations at the Staging Area. Note the Staging Area must be located outside the EPZ and near the incident site.	
	<input type="checkbox"/> Evaluate ignition criteria and communicate with the Incident Commander regarding ignition decision.	
	<input type="checkbox"/> Ensure field responders are promptly notified of any status updates.	
	<input type="checkbox"/> Continually reassess the situation and the risk to life and safety.	
	Level 3	
	<input type="checkbox"/> Continue with previous actions.	
	<input type="checkbox"/> Confirm with Public Protection Group Supervisor that all members of the public in the EPZ have been evacuated and/or sheltered.	
	<input type="checkbox"/> Ensure Public Protection Group Supervisor has established a protocol for resident updates and evacuees are provided with updated information.	
	<input type="checkbox"/> Maintain security.	
	<input type="checkbox"/> Evaluate monitoring data and expand planning zone if required.	
	<input type="checkbox"/> Review Ignition Criteria to determine if any one of the criteria have been met and coordinate ignition decision with the Incident Commander.	

OPERATIONS SECTION CHIEF	
Deactivation	
<input type="checkbox"/>	Discuss downgrading of emergency with Incident Commander once it has been determined that the incident site is controlled.
<input type="checkbox"/>	Notify all responders once the decision to downgrade the emergency has been made.
<input type="checkbox"/>	If a serious injury or death has occurred, the scene must be left as undisturbed as possible until the appropriate authorities can complete a site investigation.
<input type="checkbox"/>	In coordination with the Planning Section and Public Protection Group Supervisor, develop a re-entry plan that ensures, security of residences and safety of people including, maintaining EPZ roadblocks, appropriate messaging for evacuees, Air quality and comfortable conditions in evacuated residences and any other appropriate re-entry considerations.
<input type="checkbox"/>	Instruct the Public Protection Group Supervisor to implement re-entry plan.
<input type="checkbox"/>	Ensure that the Public Protection Group Supervisor notifies all evacuees that the emergency has been downgraded.
<input type="checkbox"/>	Ensure that the Public Protection Group Supervisor and re-entry team assist evacuees in returning to their residences/businesses as required.
<input type="checkbox"/>	Ensure that the Public Protection Group Supervisor collects all Resident Expense Claims form and forward them to the Finance Admin Section Chief.
<input type="checkbox"/>	Gather all incident related documentation from the Operations Sections and forward to the Site Planning Section Chief.
<input type="checkbox"/>	Participate in post-incident debriefing held by Incident Commander.
<input type="checkbox"/>	Participate in any Critical Incident Stress Debriefing, as required.

SITE OPERATIONS SECTION CHIEF

Forms	
<input type="checkbox"/>	ICS 204 – Assignment List
<input type="checkbox"/>	ICS 214 – Activity Log
<input type="checkbox"/>	ICS 215 – Operational Planning Worksheet (to be completed with support from Site Safety Officer and Site Logistics Section Chief or CEOC Logistics Chief)
<input type="checkbox"/>	ICS 234 – Work Analysis Matrix
<input type="checkbox"/>	Status Board

3.5 Public Protection Group Supervisor

The Public Protection Group Supervisor is responsible for initiating and managing public protection measures. Working closely with air quality monitoring, evacuation and roadblock personnel, the Public Protection Group Supervisor ensures the efficient notification and/or evacuation of residents, businesses, industrial operators and transients.

PUBLIC PROTECTION GROUP SUPERVISOR	
Location	
<input type="checkbox"/>	Incident Command Post
Takes Direction From	
<input type="checkbox"/>	Site Operations Section Chief.
Gives Direction To	
<input type="checkbox"/>	Roadblock Team Leader.
<input type="checkbox"/>	Rover Evacuation Team Leader.
<input type="checkbox"/>	Air Quality Monitoring Team Leader.
<input type="checkbox"/>	Reception Team Leader.
<input type="checkbox"/>	Telephone Team Leader.
Alert/Minor	
<input type="checkbox"/>	Document all activities utilizing the ICS 214 – Activity Log.
<input type="checkbox"/>	Determine operating location and setup as necessary.
<input type="checkbox"/>	Determine what resources your position may require.
<input type="checkbox"/>	Review ERP map.
Level 1	
<input type="checkbox"/>	Continue with previous actions.
<input type="checkbox"/>	Establish communication with the Site Operations Section Chief.
<input type="checkbox"/>	Proceed to Incident Command Post.
<input type="checkbox"/>	In coordination with the Incident Commander and Site Operations Section Chief, determine applicable public protection method, public notification/evacuation, EPZ isolation (roadblock), air quality monitoring and Reception Centre activation strategy.
<input type="checkbox"/>	Identify and if needed, acquire appropriate resources to initiate public protection including the following positions: Roadblock, Rover, Air Quality Monitoring, Reception and Telephone Team members.
<input type="checkbox"/>	With the Public Protection Team, review public protection requirements, EPZ inventory, wind direction and speed, roadblock locations and downwind impacts.
<input type="checkbox"/>	In coordination with Site Safety Officer, instruct the Public Protection Team on safe protocols, procedures and messaging for each component of the public protection strategy.
<input type="checkbox"/>	Ensure the Public Protection Team retrieves the public messaging scripts appropriate for the public protection method being employed (Voluntary Evacuation, Shelter-In Place, Media Messaging).
<input type="checkbox"/>	When instructed, implement the required voluntary evacuation assistance to residents identified as having special needs.
<input type="checkbox"/>	If required, request the Reception Centre Team to establish the reception centre. Ensure they have all the required documentation, public messaging and media releases (if required).
<input type="checkbox"/>	Dispatch the appropriate Air Quality Team members to begin developing base line air quality in any downwind un-evacuated areas.
<input type="checkbox"/>	Ensure incident information and status updates are relayed to the Reception Centre Team for the evacuees.
<input type="checkbox"/>	Establish and maintain reporting cycles with all Public Protection Team Leaders.

PUBLIC PROTECTION GROUP SUPERVISOR

PUBLIC PROTECTION GROUP SUPERVISOR	
PUBLIC PROTECTION GROUP SUPERVISOR	Level 2
	<input type="checkbox"/> Continue with previous actions.
	<input type="checkbox"/> Ensure the Public Protection Team has the public messaging scripts appropriate for the Public Protection Method being employed (Mandatory Evacuation, Shelter-In Place, Roadblock message and Media Messaging).
	<input type="checkbox"/> Ensure the Telephone Team Leader contacts residents and other non-resident land users to evacuate or Shelter-In-Place as instructed. Gather all contact/non-contact information and relay to the Rover Team Leader.
	<input type="checkbox"/> Ensure the Rover Evacuation Team travels the EPZ and contacts residents, transients, and non-resident land users in person.
	<input type="checkbox"/> Ensure the EPZ has been swept in a timely fashion and roadblocks are in place to isolate the EPZ.
	<input type="checkbox"/> If not established at a Level 1, instruct the Reception Centre Team to establish the Reception Centre. Ensure they have all the required documentation and public messaging.
	<input type="checkbox"/> Ensure air quality monitoring occurs downwind with priority being directed to the nearest unevacuated residence or areas where people may be present.
	<input type="checkbox"/> Record all air quality monitoring results from the Air Quality Monitoring Team Leader.
	<input type="checkbox"/> Ensure field responders are promptly notified of any status updates.
	<input type="checkbox"/> Continually reassess the situation and the risk to life and safety.
	<input type="checkbox"/> Review information from the Roadblock, Rover, Evacuation, Air Quality Monitoring and Telephoner Teams.
	<input type="checkbox"/> At pre-determined intervals, report status and discuss responses with Site Operations Section Chief.
	Level 3
	<input type="checkbox"/> Continue with previous actions.
	<input type="checkbox"/> Update the Site Operations Section Chief of status
	<input type="checkbox"/> Ensure Rover Evacuation Team has successfully evacuated the EPZ.
	<input type="checkbox"/> Ensure the Roadblock Team Leader maintains roadblocks as required.
	<input type="checkbox"/> Ensure the EPZ is being monitored effectively by the Air Quality Monitoring Team Leader.
	<input type="checkbox"/> Ensure Telephone Team Leader is providing ongoing status updates to impacted stakeholders.
	<input type="checkbox"/> Ensure Reception Team Leader has a record of all evacuees and has provided and expense claim forms for all evacuees.
	Deactivation
	<input type="checkbox"/> Ensure all evacuees are notified of the downgrading of the level of emergency.
	<input type="checkbox"/> In coordination with the Site Operations Section Chief and Planning Section, develop a re-entry plan that ensures security of residences and safety of people including maintaining EPZ roadblocks, appropriate messaging for evacuees, air quality and comfortable conditions in evacuated residences and any other appropriate re-entry considerations.
	<input type="checkbox"/> Using the Public Protection Team, Implement re-entry plan for evacuees. Ensure residences/businesses are ventilated as required and that monitoring of gas pockets continues to take place.
	<input type="checkbox"/> Ensure evacuees are provided assistance in returning to their residences/businesses as necessary.
	<input type="checkbox"/> Ensure evacuee's evacuation expenses and damage claims are collected.
	<input type="checkbox"/> Gather all incident related documentation from the Public Protection Team and forward to the Site Planning Section Chief.
	<input type="checkbox"/> Participate in the post-incident debriefing held by the Incident Commander.
	<input type="checkbox"/> Participate in any Critical Incident Stress Debriefing as required.

Forms	
<input type="checkbox"/>	ICS 214 – Activity Log
<input type="checkbox"/>	Stakeholder Contact Record
<input type="checkbox"/>	ICS 234 – Work Analysis Matrix
<input type="checkbox"/>	Status Board

3.5.1 Roadblock Team Leader

The Roadblock Team Leader has the responsibility to secure the perimeter of the EPZ through road closures and monitoring in coordination with the local police, local authority, or road maintenance personnel. The leader will appoint an appropriate number of personnel to isolate the EPZ and manage span of control.

ROADBLOCK TEAM LEADER	
Location	
<input type="checkbox"/>	Location not pre-determined.
Takes Direction From	
<input type="checkbox"/>	Public Protection Group Supervisor.
Confers With	
<input type="checkbox"/>	Public Protection Team.
Gives Direction To (via Roadblock Team)	
<input type="checkbox"/>	Road Traffic.
Alert/Minor	
<input type="checkbox"/>	Document all activities utilizing the ICS 214 – Activity Log.
<input type="checkbox"/>	Review the ERP map and identify all roadblock locations.
<input type="checkbox"/>	Dispatch Roadblock Team members to your location for briefing. Instruct them to identify and acquire appropriate equipment to establish their assigned roadblock location. Appoint personnel to positions that allow for management of span of control appropriately. Request them to stand by.
<input type="checkbox"/>	Ensure roadblock team is familiar with alternate routes in the area and directions to the Reception Centre if established.
<input type="checkbox"/>	Instruct Roadblock Team on safe protocols, procedures, public messaging and forms for establishing and maintaining roadblock positions.
<input type="checkbox"/>	Obtain safety equipment including SCBA, H ₂ S and LEL monitors (handheld instruments), barricade tape and radio communication as required.
<input type="checkbox"/>	Review vehicle requirements to carry out your assignment.
<input type="checkbox"/>	Fill vehicle fuel tank.
Level 1	
<input type="checkbox"/>	Continue with previous actions.
<input type="checkbox"/>	Maintain communication with the Roadblock Team and Public Protection Group Supervisor.
<input type="checkbox"/>	Continually assess weather conditions in and around the area of emergency.
<input type="checkbox"/>	In coordination with the Public Protection Group Supervisor. Ensure Roadblock team maintains readiness.
<input type="checkbox"/>	As required, dispatch roadblock teams to their assigned roadblock locations using a safe route and stand by.
Level 2	
<input type="checkbox"/>	Continue with previous actions.
<input type="checkbox"/>	Establish roadblocks at required sites to secure identified EPZ.
<input type="checkbox"/>	Engage the four-way flashers on your vehicle and don illuminated traffic vest so you are visible to traffic.
<input type="checkbox"/>	Do not completely block the road, leave at least one lane open.
<input type="checkbox"/>	Take air quality monitoring readings periodically for your safety and reposition as necessary. Document all readings, including zero.
<input type="checkbox"/>	Record any incoming and outgoing vehicles and equipment.
<input type="checkbox"/>	Confirm if the residents leaving the EPZ are proceeding to the designated Reception Centre.
<input type="checkbox"/>	Update the Public Protection Group Supervisor of status at scheduled intervals.

ROADBLOCK TEAM LEADER

ROADBLOCK TEAM LEADER	
ROADBLOCK TEAM	Level 3
	<input type="checkbox"/> Continue with previous actions.
	<input type="checkbox"/> Report any significant or unusual activities.
	Deactivation
	<input type="checkbox"/> Ensure all roadblock equipment is cleaned and returned to its proper location.
	<input type="checkbox"/> Gather all incident related documentation from the Roadblock Team and forward to the Public Protection Group Supervisor if appointed, or Planning Section
	<input type="checkbox"/> Participate in the post-incident debriefing held by the Incident Commander.
	<input type="checkbox"/> Participate in any Critical Incident Stress Debriefing as required.

Note: The licensee has the responsibility to protect the public by activating roadblocks. Restricting access to the hazard area will remain under the authority of the applicable agency (i.e. police, RCMP, fire department, road maintenance contractor, regulatory authority, etc.). If someone insists on going through the roadblock, attempt to gather their information and provide it through your chain of command

Forms	
<input type="checkbox"/>	ICS 214 – Activity Log
<input type="checkbox"/>	Roadblock Checkpoint Record
<input type="checkbox"/>	Environmental Monitoring Record
<input type="checkbox"/>	Roadblock Statement
<input type="checkbox"/>	Media Message

3.5.2 Rover Evacuation Team Leader

The Rover Evacuation Team Leader is responsible for identifying and evacuating all members of the public within the response zones. He/she provides support to those who need evacuation assistance by checking residences, businesses, trappers, Guide/Outfitters, transients, and seasonal and casual area users. **Note:** wording in forms for public interface may need to be adjusted for in person delivery rather than telephone delivery.

ROVER EVACUATION TEAM LEADER	
Location	
<input type="checkbox"/>	Location not pre-determined.
Takes Direction From	
<input type="checkbox"/>	Public Protection Group Supervisor.
Confers With	
<input type="checkbox"/>	Public Protection Team, Public Protection Supervisor
Gives Direction To (via Rover Evacuation Team)	
<input type="checkbox"/>	Residents.
<input type="checkbox"/>	Businesses.
<input type="checkbox"/>	Trappers.
<input type="checkbox"/>	Guide/Outfitters.
<input type="checkbox"/>	Transients.
<input type="checkbox"/>	Seasonal and casual area users.
Alert/Minor	
<input type="checkbox"/>	Document all activities utilizing the ICS 214 – Activity Log.
<input type="checkbox"/>	Establish communication with the Public Protection Group Supervisor.
<input type="checkbox"/>	Review the ERP map. Identify all stakeholders in the EPZ.
<input type="checkbox"/>	Determine number of personnel required to efficiently communicate with people and sweep the EPZ.
<input type="checkbox"/>	Consider the need for a helicopter evacuation team to assist with evacuation in large or difficult terrain. Check availability
<input type="checkbox"/>	Review all forms and messaging required for the different levels of emergency. Confer with Public Protection Group Supervisor on appropriate messages to deliver.
<input type="checkbox"/>	Obtain safety equipment including SCBA, H ₂ S and LEL monitors (handheld instruments) and radio communication, as required.
<input type="checkbox"/>	Ensure a sufficient supply of appropriate forms.
<input type="checkbox"/>	Review vehicle requirements to carry out your assignment.
<input type="checkbox"/>	Fill vehicle fuel tank.
<input type="checkbox"/>	Review product release rates, wind direction, and safest egress routes.
Level 1	
<input type="checkbox"/>	Continue with previous actions.
<input type="checkbox"/>	Review the boundaries of the response zones.
<input type="checkbox"/>	Reevaluate how many members of the public could be inside the EPZ and the response zones. Account for residents, businesses, First Nations persons, trappers, guide/outfitters, grazing lessees and transients.
<input type="checkbox"/>	Identify highways, waterways, railroads, airports, campgrounds, hiking trails, etc. where stakeholders may be located.
<input type="checkbox"/>	Assess weather conditions in and around the area of the emergency. Determine if weather conditions could impact or impede emergency response efforts.
<input type="checkbox"/>	Identify and gather the required number of Rovers. Review map, forms, public messaging, location each are to rove and communication protocols. Standby and prepare to dispatch.
<input type="checkbox"/>	Prepare and implement Incident Action Plan in coordination with the Public Protection Group Supervisor.
<input type="checkbox"/>	Commence transient survey.
<input type="checkbox"/>	Advise members of the public that requested early notification or identified as having special needs of the incident. Provide evacuation assistance if requested.
<input type="checkbox"/>	Gather all Telephone Team contact data from the Public Protection Group Supervisor. Advise Rover Evacuation team of telephone contact status.

ROVER EVACUATION TEAM LEADER

ROVER EVACUATION TEAM LEADER	
ROVER EVACUATION TEAM LEADER	Level 2
	<input type="checkbox"/> Continue with previous actions.
	<input type="checkbox"/> Report any observations or issues which may negatively impact evacuations.
	<input type="checkbox"/> Take air quality monitoring readings periodically for your safety. Document all readings, including zero.
	<input type="checkbox"/> Ensure all public locations are visited and evacuated.
	<input type="checkbox"/> When contacting stakeholders identify yourself, speak slowly and confidently.
	<input type="checkbox"/> Document time of arrival.
	<input type="checkbox"/> Account for all members of the household, business or dwelling. Inquire as to the whereabouts of anyone not present.
	<input type="checkbox"/> Review the condition of stakeholders and identify any special requirements.
	<input type="checkbox"/> Relay travel time and directions to the reception centre using safe egress routes.
	<input type="checkbox"/> Check all fields and vacant locations to ensure that they are empty.
	<input type="checkbox"/> Post a Notice of Evacuation on all doors of each unoccupied residence and business, on each outbuilding and the windshield of each unattended vehicle within the evacuated zones.
	<input type="checkbox"/> Expand transient survey if EPZ is increased.
	<input type="checkbox"/> Update the Public Protection Group Supervisor of status at scheduled intervals.
	Level 3
	<input type="checkbox"/> Continue with previous actions.
	<input type="checkbox"/> Ensure EPZ has been evacuated.
	<input type="checkbox"/> Update the Public Protection Group Supervisor of status at scheduled intervals.
	Deactivation
	<input type="checkbox"/> Continue to monitor for gas pockets.
	<input type="checkbox"/> Assist evacuees in returning to their residences/businesses as required.
	<input type="checkbox"/> Ventilate residences/businesses as required.
	<input type="checkbox"/> Provide Company phone number in the event of additional concerns or questions.
	<input type="checkbox"/> Gather all incident related documentation from the Rover Team and forward to the Public Protection Group Supervisor if appointed, or Planning Section
	<input type="checkbox"/> Participate in the post-incident debriefing held by the Incident Commander.
<input type="checkbox"/> Participate in any Critical Incident Stress Debriefing, as required.	

Forms (All Rover Team)	
<input type="checkbox"/>	ICS 214 – Activity Log
<input type="checkbox"/>	ICS 234 – Work Analysis Matrix
<input type="checkbox"/>	Stakeholder Contact Record
<input type="checkbox"/>	Media Message
<input type="checkbox"/>	Environmental Monitoring Record
Public Protection Messages/Scripts	
<input type="checkbox"/>	Notification Script
<input type="checkbox"/>	General Evacuation Script
<input type="checkbox"/>	Shelter In Place script
<input type="checkbox"/>	Urgent Evacuation Script
<input type="checkbox"/>	Notice of Evacuation

3.5.3 Air Quality Monitoring Team Leader

The Air Quality Monitoring Team uses air quality monitoring equipment and personnel to identify and track the extent of the plume associated with a gas release to atmosphere.

AIR QUALITY MONITORING TEAM LEADER	
Location	
<input type="checkbox"/>	Location not pre-determined.
Takes Direction From	
<input type="checkbox"/>	Public Protection Group Supervisor.
Confers With	
<input type="checkbox"/>	Public Protection Team.
Gives Direction To	
<input type="checkbox"/>	Mobile air quality monitoring unit.
Alert/Minor	
<input type="checkbox"/>	Document all activities utilizing the ICS 214 – Activity Log.
<input type="checkbox"/>	Review ERP map, product release rates, wind direction, and safest egress routes.
<input type="checkbox"/>	Review stakeholder locations and proximity to urban developments.
<input type="checkbox"/>	Obtain radio communication equipment, as required.
<input type="checkbox"/>	Verify operational condition and appropriateness of plume monitoring equipment.
<input type="checkbox"/>	Ensure a sufficient supply of appropriate forms.
<input type="checkbox"/>	Review vehicle requirements to carry out your assignment.
<input type="checkbox"/>	Fill vehicle fuel tank.
Level 1	
<input type="checkbox"/>	Continue with previous actions.
<input type="checkbox"/>	Establish communication with the Public Protection Group Supervisor.
<input type="checkbox"/>	Prepare and implement Incident Action Plan in coordination with the Public Protection Group Supervisor.
<input type="checkbox"/>	If safe to do so, perform air quality monitoring with hand-held aspirating detectors until mobile air quality monitoring unit arrives. Document all readings, including zero.
<input type="checkbox"/>	Confirm dispatch of the mobile air quality monitoring unit, if required.
Level 2	
<input type="checkbox"/>	Continue with previous actions.
<input type="checkbox"/>	Track the plume perimeter and record measured concentration.
<input type="checkbox"/>	Where a release has the possibility of being sustained, the EPZ must be redefined using mobile monitoring vehicles equipped with devices to continuously measure and record wind speed, directions and concentrations.
<input type="checkbox"/>	Air quality monitoring must occur downwind with priority being directed to the nearest un-evacuated residence or area where people may be present.
<input type="checkbox"/>	If the EPZ includes a portion of an urban density development, mobilize sufficient air quality monitoring units so that one unit will be dedicated to the urban density development.
<input type="checkbox"/>	In coordination with the Public Protection Group Supervisor, provide monitored information to applicable Regulatory Authority, local authority, local health authority and environmental authority on a regular basis throughout the emergency.
<input type="checkbox"/>	Update the Public Protection Group Supervisor of status at scheduled intervals.
Level 3	
<input type="checkbox"/>	Continue with previous actions.
<input type="checkbox"/>	Ensure the EPZ is being monitored effectively.
<input type="checkbox"/>	Provide Air Quality Monitoring Record reports to the Public Protection Group Supervisor.
<input type="checkbox"/>	Update the Public Protection Group Supervisor of status at scheduled intervals.

AIR QUALITY MONITORING TEAM LEADER

AIR QUALITY MONITORING TEAM LEADER	
AIR QUALITY MONITORING	Deactivation
	<input type="checkbox"/> Collect and submit all reports and documents to the Public Protection Group Supervisor.
	<input type="checkbox"/> Determine from the Public Protection Group Supervisor if your position will require any follow up actions before you leave the scene.
	<input type="checkbox"/> Participate in the post-incident debriefing held by the Incident Commander.
	<input type="checkbox"/> Participate in the Critical Incident Stress Debriefing as required.
Forms	
<input type="checkbox"/>	ICS 214 – Activity Log
<input type="checkbox"/>	Media Message
<input type="checkbox"/>	Environmental Monitoring Record

3.5.4 Reception Team Leader

The Reception Team Leader is responsible for establishing a Reception Centre at a suitable location outside the EPZ and addressing the concerns and immediate needs of evacuated stakeholders.

RECEPTION TEAM LEADER	
Location	
<input type="checkbox"/>	Reception Centre.
Takes Direction From	
<input type="checkbox"/>	Public Protection Group Supervisor.
Confers With	
<input type="checkbox"/>	Public Protection Team.
Gives Direction To	
<input type="checkbox"/>	Evacuated stakeholders.
Alert/Minor	
<input type="checkbox"/>	Document all activities utilizing the ICS 214 – Activity Log.
<input type="checkbox"/>	Prepare reception centre kit (pen, paper, area phone book, registration forms, and title badges).
Level 1	
<input type="checkbox"/>	Continue with previous actions.
<input type="checkbox"/>	Identify appropriate Reception Centre.
<input type="checkbox"/>	Contact reception centre to make necessary arrangements.
<input type="checkbox"/>	Determine number of personnel required to efficiently manage the Reception Centre. Identify and, if required, dispatch additional Reception Centre Personnel to your location.
<input type="checkbox"/>	Review map, forms, public messaging, and communication protocols. Stand by and be prepared to start.
<input type="checkbox"/>	Review all forms and messaging required for evacuated people at the Reception Centre. Confer with Public Protection Group Supervisor on appropriate messages to deliver.
<input type="checkbox"/>	Prepare and implement Incident Action Plan in coordination with the Public Protection Group Supervisor.
<input type="checkbox"/>	Proceed to designated Reception Centre and prepare facility to receive evacuees if evacuation is probable.
<input type="checkbox"/>	Request, receive and deliver incident information and status to the evacuees.
<input type="checkbox"/>	Set up communication with the Public Protection Group Supervisor.
Level 2	
<input type="checkbox"/>	Continue with previous actions.
<input type="checkbox"/>	Receive evacuees and record names of evacuees who arrive at the Reception Centre.
<input type="checkbox"/>	Receive school children who live inside the EPZ whose school buses have been redirected to the Reception Centre. Children must be supervised until they are picked up by their parents or guardians.
<input type="checkbox"/>	If necessary, arrange for a school administrator to come to the Reception Centre.
<input type="checkbox"/>	Address evacuees' immediate needs for food and housing.
<input type="checkbox"/>	Ensure all media releases, company public messages and status update forms are posted in the Reception Centre.
<input type="checkbox"/>	Provide information to the evacuees on the status of the incident.
<input type="checkbox"/>	Record details of temporary destinations and contact numbers when evacuees leave the Reception Centre.
<input type="checkbox"/>	Discuss immediate expense issues. Provide expense claim forms as requested.
<input type="checkbox"/>	Relay concerns regarding requirements for ongoing care of livestock to the Public Protection Group Supervisor, if applicable.
<input type="checkbox"/>	Provide support to evacuees who may be emotionally upset.
<input type="checkbox"/>	Update the Public Protection Group Supervisor of status at scheduled intervals.
Level 3	
<input type="checkbox"/>	Continue with previous actions.
<input type="checkbox"/>	Verify with Public Protection Group Supervisor that all members of the public have been evacuated.
<input type="checkbox"/>	Continue with status updates for residents and other concerned members of the public.
<input type="checkbox"/>	Update telephone contacts for evacuees as required.
<input type="checkbox"/>	Update the Public Protection Group Supervisor of status at scheduled intervals.

RECEPTION TEAM LEADER

RECEPTION TEAM LEADER	
RECEPTION TEAM	Deactivation
	<input type="checkbox"/> Advise evacuees that they may return to their residences and arrange any assistance.
	<input type="checkbox"/> Collect and document all evacuation expense claims, provide copies to the Public Protection Group Supervisor.
	<input type="checkbox"/> Gather all incident related documentation from the Reception Centre Team and forward to the Public Protection Group Supervisor.
	<input type="checkbox"/> Provide Company phone number in the event of additional concerns or questions.
	<input type="checkbox"/> Participate in post-incident debriefing held by the Incident Commander.
	<input type="checkbox"/> Participate in the Critical Incident Stress Debriefing as required.

Forms	
<input type="checkbox"/>	ICS 214 – Activity Log
<input type="checkbox"/>	Evacuee Expense Claim Form
<input type="checkbox"/>	Reception Centre Registration Form
<input type="checkbox"/>	Media Message

3.5.5 Telephone Team Leader

The Telephone Team Leader is responsible for contacting impacted stakeholders to provide updates regarding any emergency situation when necessary. Communication will be facilitated using the appropriate scripts as a guide.

TELEPHONE TEAM LEADER	
Location	
<input type="checkbox"/>	Location not pre-determined.
Takes Direction From	
<input type="checkbox"/>	Public Protection Group Supervisor.
Confers With	
<input type="checkbox"/>	Public Protection Team.
Gives Direction To (via Telephone Team)	
<input type="checkbox"/>	Area Stakeholders.
Alert/Minor	
<input type="checkbox"/>	Document all activities utilizing the ICS 214 – Activity Log.
<input type="checkbox"/>	Review the ERP map.
<input type="checkbox"/>	Assemble required telephone team forms.
<input type="checkbox"/>	Review area stakeholder list and phone numbers, if applicable.
<input type="checkbox"/>	Review the Communication Plan scripts.
<input type="checkbox"/>	Identify appropriate space and communication devices to facilitate stakeholder telephone notification, if required.
Level 1	
<input type="checkbox"/>	Continue with previous actions.
<input type="checkbox"/>	Develop and implement Incident Action Plan in coordination with the Public Protection Group Supervisor.
<input type="checkbox"/>	Standby and prepare to initiate stakeholder telephone notification.
<input type="checkbox"/>	Recruit and review action plan with assistants as required.
<input type="checkbox"/>	Prepare evacuation or shelter-in-place phone messages based on direction from the Public Protection Group Supervisor. Use scripts in the manual for consistent wording and clarity.
<input type="checkbox"/>	Gather location and directions to the Reception Centre. Ensure all team members have Reception centre information.
<input type="checkbox"/>	Notify stakeholders and other area users inside the EPZ so they may choose whether to voluntarily evacuate.
<input type="checkbox"/>	An automated telephone notification system can be used but prepare to follow-up the automated system with personal contact from the Telephoner Team.
<input type="checkbox"/>	Record all details of contacts using the Stakeholder Contact Record for documentation.
<input type="checkbox"/>	Advise the Public Protection Group Supervisor about stakeholders requiring assistance.
<input type="checkbox"/>	Update the Public Protection Group Supervisor of status.
Level 2	
<input type="checkbox"/>	Continue with previous actions.
<input type="checkbox"/>	Contact stakeholders and other area users in EPZ and advise them to evacuate.
<input type="checkbox"/>	Confirm the location of the Reception Centre so coordination with stakeholders can occur.
<input type="checkbox"/>	If school is in session, contact impacted schools and school bus authorities. This contact is not to be made by an automated telephone system.
<input type="checkbox"/>	Coordinate with the Reception Team Leader and request a school administrator assist with the effective management of the students and parents at the Reception Centre.
<input type="checkbox"/>	Document and track the status of stakeholders who have evacuated or sheltered.
<input type="checkbox"/>	Update the Public Protection Group Supervisor of status at scheduled intervals.
Level 3	
<input type="checkbox"/>	Continue with previous actions.
<input type="checkbox"/>	Continue phoning stakeholders who have been unreachable.
<input type="checkbox"/>	Remain on standby to assist with telephone calls as required.
<input type="checkbox"/>	Update the Public Protection Group Supervisor of status at scheduled intervals.

TELEPHONE TEAM LEADER

TELEPHONE TEAM LEADER	
TELEPHONE TEAM	Deactivation
	<input type="checkbox"/> As instructed by the Public Protection Group Supervisor, advise all evacuees that they may return.
	<input type="checkbox"/> Ensure a post-incident telephone message is communicated to the public impacted by the emergency.
	<input type="checkbox"/> Collect all incident related documentation from the telephone team and submit to the Public Protection Group Supervisor.
	<input type="checkbox"/> Participate in the post-incident debriefing held by the Incident Commander.
	<input type="checkbox"/> Participate in the Critical Incident Stress Debriefing as required.

Forms	
<input type="checkbox"/>	ICS 214 – Activity Log
<input type="checkbox"/>	ICS 234 – Work Analysis Matrix
<input type="checkbox"/>	Stakeholder Contact Record
Public Protection Messages/Scripts	
<input type="checkbox"/>	Notification Script
<input type="checkbox"/>	General Evacuation Script
<input type="checkbox"/>	Shelter In Place script
<input type="checkbox"/>	Urgent Evacuation Script

3.6 On-Site Group Supervisor

The On-Site Group Supervisor is responsible for establishing the On-Site Command Post and coordinating personnel and equipment to address control, containment and recovery from the incident.

ON-SITE GROUP SUPERVISOR	
Location	
<input type="checkbox"/>	On-Site Command Post.
Takes Direction From	
<input type="checkbox"/>	Site Operations Section Chief.
Confers With	
<input type="checkbox"/>	Public Protection Group Supervisor.
Gives Direction To	
<input type="checkbox"/>	Fire Control Team Leader.
<input type="checkbox"/>	Isolation/Repair Team Leader.
<input type="checkbox"/>	Spill Response Team Leader.
<input type="checkbox"/>	Security Team Leader.
<input type="checkbox"/>	Ignition Team Leader.
<input type="checkbox"/>	On-Site Safety Team Leader
Alert/Minor	
<input type="checkbox"/>	Document all activities utilizing the ICS 214 – Activity Log.
<input type="checkbox"/>	Identify hazards.
<input type="checkbox"/>	Attend to medical needs.
<input type="checkbox"/>	Request emergency medical services, as required.
<input type="checkbox"/>	Isolate the scene.
Level 1	
<input type="checkbox"/>	Continue with previous actions.
<input type="checkbox"/>	Establish communication with the Site Operations Section Chief.
<input type="checkbox"/>	Discuss the incident situation and actions to be taken with the Site Operations Section Chief.
<input type="checkbox"/>	Release non-essential personnel.
<input type="checkbox"/>	Isolate the immediate area until the Public Protection Group Supervisor assumes this responsibility.
<input type="checkbox"/>	Activate appropriate Source Control Team Leaders to address the incident.
<input type="checkbox"/>	Ensure all on-site personnel follow the appropriate safe work procedures.
<input type="checkbox"/>	Ensure all on-site personnel have the appropriate training and personal protective equipment.
<input type="checkbox"/>	Assess the requirements for on-site safety supervision, equipment, and personnel. Appoint On-Site Safety Team Leader as required.
<input type="checkbox"/>	Coordinate on-site responses to gain control, shutdown, isolate, and depressure equipment, as required.
<input type="checkbox"/>	Review dangerous conditions near the incident site. For example, fuel leaks, toxic gas releases, oxygen deficiency, BLEVE, ignition sources and chemical leaks.
<input type="checkbox"/>	Build dykes with available materials to stop leaks from travelling off-lease or into waterways.
<input type="checkbox"/>	Evaluate ignition criteria and communicate with the Site Operations Section Chief regarding ignition decision.
<input type="checkbox"/>	Obtain spill samples as required and monitor environment for adverse effects.
<input type="checkbox"/>	Record and report all readings at established intervals to the Site Operations Section Chief.
Level 2	
<input type="checkbox"/>	Continue with previous actions.
<input type="checkbox"/>	Update the Site Operations Section Chief of status.
<input type="checkbox"/>	Continue spill sampling.
<input type="checkbox"/>	Ensure field responders are promptly notified of any status updates.
<input type="checkbox"/>	Continually reassess the situation and the risk to life and safety.
<input type="checkbox"/>	In conjunction with the Site Operations Section Chief, choose a qualified ignition team, discuss ignition duties and check ignition equipment in advance of meeting any ignition criteria.
<input type="checkbox"/>	Confirm with the Site Operations Section Chief that you have the authority to ignite, if required.

ON-SITE GROUP SUPERVISOR

ON-SITE GROUP SUPERVISOR	
ON-SITE GROUP SUPERVISOR	Level 3
	<input type="checkbox"/> Continue with previous actions.
	<input type="checkbox"/> Update the Site Operations Section Chief of status at scheduled intervals.
	<input type="checkbox"/> Initiate ignition procedure if ignition criteria have been met (upon consultation with Site Operations Section Chief).
	Deactivation
	<input type="checkbox"/> Ensure site is safe.
	<input type="checkbox"/> Ensure the incident site is not disturbed until all necessary site investigations have been completed by the appropriate authority.
	<input type="checkbox"/> Ensure all work areas, safety equipment, machinery, and tools are cleaned, repaired and returned to their proper location.
	<input type="checkbox"/> Ensure that on-site personnel and equipment including contracted services are decontaminated before leaving the incident site.
	<input type="checkbox"/> Collect all incident related documentation from the on-site teams and submit to the Site Operations Section Chief.
	<input type="checkbox"/> Participate in the post-incident debriefing held by the Incident Commander.
	<input type="checkbox"/> Participate in any Critical Stress Incident Debriefing, as required.

Forms	
<input type="checkbox"/>	ICS 214 – Activity Log
<input type="checkbox"/>	ICS 234 – Work Analysis Matrix
<input type="checkbox"/>	Spill/Release Written Report Form

3.6.1 On Site Safety Team Leader

Safety backup/site safety person. Provide advice to On-site Group Supervisor on safety procedures. Site Safety has the authority to alter or suspend any on-site activities that pose an immediate life safety threat. For all other activities that are considered unsafe, site safety may recommend corrective actions.

ON SITE SAFETY TEAM LEADER	
Location	
<input type="checkbox"/>	On-Site Command Post.
Takes Direction From	
<input type="checkbox"/>	On-Site Group Supervisor.
Confers With	
<input type="checkbox"/>	Medical Responders
<input type="checkbox"/>	Local Fire Department.
<input type="checkbox"/>	Industrial Firefighters.
<input type="checkbox"/>	On-Site Team.
Gives Direction To	
<input type="checkbox"/>	All On-Site Personnel.
Initial Response	
<input type="checkbox"/>	Report to the On-site Command Post (OSCP). Check in with the On-site Group Supervisor and obtain a briefing.
<input type="checkbox"/>	Identify current and potential responder safety hazards and life safety risks.
<input type="checkbox"/>	As appropriate ensure on site air quality is monitored. Document all monitoring levels and time stamps (including zero)
<input type="checkbox"/>	Promptly and clearly make safety concerns known to On-Site Group Supervisor.
<input type="checkbox"/>	Manage or support safe medical response. Ensure the use of STARS Remote Landing Zone Reference Card as required.
<input type="checkbox"/>	Stop and/or prevent unsafe acts.
<input type="checkbox"/>	Ensure incident scene is undisturbed except for emergency remedial actions and is recorded by diagrams and/or photographs.
<input type="checkbox"/>	Determine your staffing requirements (assistant, on-site safety, replacement).
<input type="checkbox"/>	Begin filling out required documentation.
All Levels	
<input type="checkbox"/>	Immediately make safety concerns known to the On-site Group Supervisor.
<input type="checkbox"/>	Identify hazardous situations associated with the incident.
<input type="checkbox"/>	Provide advice to On-site Group Supervisor regarding establishment of safe work zones.
<input type="checkbox"/>	As required, communicate with Site Safety Officer and get necessary support.
<input type="checkbox"/>	Assist On-site Group Supervisor to ensure the appropriate requirements are being followed. For example: <ul style="list-style-type: none"> • Use of appropriate personal protective equipment (PPE) • Safe and adequate lighting is in place as necessary • First aid and burn kits are readily available • Only radios designed and approved for use in flammable atmospheres are to be used (i.e. 'intrinsically safe') • Proper grounding and bonding procedures are adhered to • Responders park vehicles in safe locations upon arrival; assess spacing to ensure there is no mass convergence or congestion that limits site access/egress • Workers who show signs of stress, fatigue or other adverse symptoms are demobilized and sent for treatment if necessary.
<input type="checkbox"/>	Using the Daily meeting Schedule document ensure details and attendance records are maintained for on Site meetings.

ON SITE SAFETY TEAM LEADER

ON SITE SAFETY TEAM LEADER	
ON SITE SAFETY	Deactivation
	<input type="checkbox"/> Advise the On-site Group Supervisor to consider Incident Stress Debriefing for personnel who may have been exposed to stressful situations during the emergency.
	<input type="checkbox"/> Determine if your position will require follow-up actions before leaving site.
	<input type="checkbox"/> Deactivate your position when authorized by the On-site Group Supervisor.
	<input type="checkbox"/> As requested, participate in the incident response debriefing meeting.
	<input type="checkbox"/> As requested, support preparation of incident investigation and reporting.
	<input type="checkbox"/> Document post-incident learnings.

Forms	
<input type="checkbox"/>	ICS 214 – Activity Log
<input type="checkbox"/>	Environmental Monitoring Record
<input type="checkbox"/>	ICS 230 Daily Meeting Schedule
<input type="checkbox"/>	STARS Remote Landing Zone Reference Card

3.6.2 Fire Control Team Leader

The Fire Control Team Leader is responsible for coordinating the fire suppression efforts with the local fire department, industrial firefighting contractors, and the On-Site Team members.

FIRE CONTROL TEAM LEADER	
Location	
<input type="checkbox"/>	On-Site Command Post.
Takes Direction From	
<input type="checkbox"/>	On-Site Group Supervisor.
Confers With	
<input type="checkbox"/>	Local Fire Department.
<input type="checkbox"/>	Industrial Firefighters.
<input type="checkbox"/>	On-Site Team.
Gives Direction To	
<input type="checkbox"/>	On-Site Fire Control Personnel.
All Levels	
<input type="checkbox"/>	Document all activities utilizing the ICS 214 – Activity Log.
<input type="checkbox"/>	Inventory number, type and location of fire extinguishers.
<input type="checkbox"/>	Proactive notification to local Fire Department.
<input type="checkbox"/>	Establish communication with the On-Site Group Supervisor.
<input type="checkbox"/>	Determine classification of fire.
<input type="checkbox"/>	Prepare and implement Incident Action Plan in coordination with the On-Site Group Supervisor.
<input type="checkbox"/>	Request assistance from local Fire Department or Industrial Firefighters. Note: <i>Site Logistics Section Chief will provide support.</i>
<input type="checkbox"/>	Use a fire extinguisher only when it can be done safely.
<input type="checkbox"/>	Contain fire until fire department or additional firefighting resources arrive.
Deactivation	
<input type="checkbox"/>	Ensure site is safe.
<input type="checkbox"/>	Ensure all work areas, safety equipment, machinery, and tools are cleaned, repaired and returned to their proper location.
<input type="checkbox"/>	Complete and submit all incident related documentation to the On-Site Group Supervisor.
<input type="checkbox"/>	Participate in the post-incident debriefing held by the Incident Commander.
<input type="checkbox"/>	Participate in any Critical Stress Incident Debriefing, as required.

FIRE CONTROL TEAM LEADER

Forms	
<input type="checkbox"/>	ICS 214 – Activity Log

3.6.3 Isolation/Repair Team Leader

The Isolation/Repair Team Leader is responsible for emergency shutdown, isolation, depressurization, troubleshooting, and repair efforts with the On-Site isolation/repair personnel and the On-Site Team members.

ISOLATION/REPAIR TEAM LEADER	
Location	
<input type="checkbox"/>	On-Site Command Post.
Takes Direction From	
<input type="checkbox"/>	On-Site Group Supervisor.
Confers With	
<input type="checkbox"/>	On-Site Team.
Gives Direction To	
<input type="checkbox"/>	On-Site isolation/repair personnel.
All Levels	
<input type="checkbox"/>	Document all activities utilizing the ICS 214 – Activity Log.
<input type="checkbox"/>	Identify hazards involved.
<input type="checkbox"/>	Account for all personnel on-site.
<input type="checkbox"/>	Evacuate immediate work area.
<input type="checkbox"/>	Go to muster point.
<input type="checkbox"/>	When possible, confirm situation with back-up personnel.
<input type="checkbox"/>	Determine if situation requires isolation and/or emergency shutdown of an individual piece of equipment.
<input type="checkbox"/>	Determine if situation requires complete shutdown of facility.
<input type="checkbox"/>	Contact the On-Site Group Supervisor for further instructions and provide the exact location of the incident.
<input type="checkbox"/>	Implement Incident Action Plan in coordination with the On-Site Group Supervisor.
Deactivation	
<input type="checkbox"/>	Ensure site is safe.
<input type="checkbox"/>	Ensure all work areas, safety equipment, machinery, and tools are cleaned, repaired and returned to their proper location.
<input type="checkbox"/>	Complete and submit all incident related documentation to the On-Site Group Supervisor.
<input type="checkbox"/>	Participate in the post-incident debriefing held by the Incident Commander.
<input type="checkbox"/>	Participate in any Critical Stress Incident Debriefing, as required.

ISOLATION/REPAIR TEAM LEADER

Forms	
<input type="checkbox"/>	ICS 214 – Activity Log
<input type="checkbox"/>	ICS 234 – Work Analysis Matrix

3.6.4 Spill Response Team Leader

The Spill Response Team Leader is responsible for coordinating spill, containment, and clean-up efforts to minimize impairment to the environment, human health, or property.

SPILL RESPONSE TEAM LEADER	
Location	
<input type="checkbox"/>	On-Site Command Post
Takes Direction From	
<input type="checkbox"/>	On-Site Group Supervisor.
Confers With	
<input type="checkbox"/>	On-Site Team.
Gives Direction To	
<input type="checkbox"/>	Spill Responders.
Alert/Minor	
<input type="checkbox"/>	Document all activities utilizing the ICS 214 – Activity Log.
<input type="checkbox"/>	Collect date, time, name, and contact numbers from the person who reports the spill.
<input type="checkbox"/>	Dispatch initial responders to incident site.
<input type="checkbox"/>	Establish site control.
<input type="checkbox"/>	Analyze the situation.
<input type="checkbox"/>	Establish a muster point.
<input type="checkbox"/>	Identify the type and volume of spill product.
<input type="checkbox"/>	Report the incident to the On-Site Group Supervisor.
<input type="checkbox"/>	Implement spill response objectives in coordination with the On-Site Group Supervisor.
Level 1	
<input type="checkbox"/>	Continue with previous actions.
<input type="checkbox"/>	Dispatch spill responders and equipment to the incident site.
<input type="checkbox"/>	Control all access to the incident site.
<input type="checkbox"/>	Identify the contamination zone, support zone, and equipment staging area.
<input type="checkbox"/>	Identify an emergency signal, escape routes, and meeting location for response personnel.
<input type="checkbox"/>	Place a wind indicator at appropriate locations.
<input type="checkbox"/>	Establish an entry and exit checkpoint at the periphery of the incident site.
<input type="checkbox"/>	Monitor weather conditions that could hinder the spill response.
<input type="checkbox"/>	Identify area stakeholders and environmental sensitivities.
<input type="checkbox"/>	Identify designated spill control points.
<input type="checkbox"/>	Initiate containment and recovery operations.
<input type="checkbox"/>	Develop a waste management plan.
<input type="checkbox"/>	Develop sampling and analysis strategy.
Level 2	
<input type="checkbox"/>	Continue with previous actions.
<input type="checkbox"/>	Establish a bulletin board.
<input type="checkbox"/>	Post site safety plan, SDS, crew roster sheets, status reports, and other relevant information.
<input type="checkbox"/>	Obtain radios and megaphones to direct communications on-site.
<input type="checkbox"/>	Establish first aid station in a visible area with appropriate facilities and supplies.
<input type="checkbox"/>	Establish a decontamination area where responders can remove contaminated clothing, wash up and return clean equipment.
<input type="checkbox"/>	Create diagrams of response strategies, e.g. trenching berm, setting up a boom, blocking a culvert, etc.

SPILL RESPONSE TEAM LEADER

SPILL RESPONSE TEAM LEADER	
SPILL RESPONSE TEAM LEADER	Level 3
	<input type="checkbox"/> Continue with previous actions.
	Deactivation
	<input type="checkbox"/> Ensure site is safe.
	<input type="checkbox"/> Ensure all work areas, safety and spill equipment, machinery, and tools are cleaned, repaired and returned to their proper location.
	<input type="checkbox"/> Complete and submit all incident related documentation to the On-Site Group Supervisor.
	<input type="checkbox"/> Participate in the post-incident debriefing held by the Incident Commander.
<input type="checkbox"/> Participate in any Critical Stress Incident Debriefing, as required.	

Forms	
<input type="checkbox"/>	ICS 214 – Activity Log
<input type="checkbox"/>	ICS 234 – Work Analysis Matrix
<input type="checkbox"/>	Spill/Release Written Report Form

3.6.5 Security Team Leader

The Security Team Leader is responsible for the security of the site and establishing boundaries to prevent unauthorized entry.

SECURITY TEAM LEADER	
Location	
<input type="checkbox"/>	On-Site Command Post.
Takes Direction From	
<input type="checkbox"/>	On-Site Group Supervisor.
Confers With	
<input type="checkbox"/>	On-Site Team.
Gives Direction To	
<input type="checkbox"/>	Security Personnel.
All Levels	
<input type="checkbox"/>	Document all activities utilizing the ICS 214 – Activity Log.
<input type="checkbox"/>	Investigate and report a security breach that has the potential to impact people, property or the environment.
<input type="checkbox"/>	Monitor and ensure security of the site.
<input type="checkbox"/>	Develop security guidelines for the site and potentially affected area.
<input type="checkbox"/>	Establish communication with the On-Site Group Supervisor at scheduled intervals.
<input type="checkbox"/>	Implement Incident Action Plan in coordination with the On-Site Group Supervisor.
<input type="checkbox"/>	Establish a security perimeter.
<input type="checkbox"/>	Control access to the incident site of non-essential personnel.
<input type="checkbox"/>	Report any significant or unusual activities immediately to the On-Site Group Supervisor.
Deactivation	
<input type="checkbox"/>	Complete and submit all incident related documentation to the On-Site Group Supervisor.
<input type="checkbox"/>	Participate in the post-incident debriefing held by the Incident Commander.
<input type="checkbox"/>	Participate in any Critical Stress Incident Debriefing, as required.

SECURITY TEAM LEADER

Forms	
<input type="checkbox"/>	ICS 211 – Check-In Record
<input type="checkbox"/>	ICS 214 – Activity Log
<input type="checkbox"/>	ICS 234 – Work Analysis Matrix

3.6.6 Ignition Team Leader

The Ignition Team Leader is responsible for reviewing pre-ignition considerations, preparing ignition equipment and assembling a trained ignition team in the event that ignition criteria is met.

IGNITION TEAM LEADER	
Location	
<input type="checkbox"/>	On-Site Command Post.
Takes Direction From	
<input type="checkbox"/>	On-Site Group Supervisor in coordination with the Site Operations Section Chief and Incident Commander.
Confers With	
<input type="checkbox"/>	On-Site Team.
Gives Direction To	
<input type="checkbox"/>	Ignition Team Members.
Alert/Minor	
<input type="checkbox"/>	Document all activities utilizing the ICS 214 – Activity Log.
<input type="checkbox"/>	Consider safety and health risks to emergency personnel.
<input type="checkbox"/>	Consider proximity of release to public areas.
<input type="checkbox"/>	Consider availability of air monitoring equipment and personnel.
<input type="checkbox"/>	Consider detectable concentrations of H ₂ S and/or flammable gases near the source of the release and within the EPZ.
<input type="checkbox"/>	Consider weather conditions.
<input type="checkbox"/>	Consider duration of the release and potential volume.
<input type="checkbox"/>	Consider impacts to livestock.
<input type="checkbox"/>	Consider impacts to other values at risk including property, timber or infrastructure.
Level 1	
<input type="checkbox"/>	Continue with previous actions.
<input type="checkbox"/>	Establish communication with the On-Site Group Supervisor.
<input type="checkbox"/>	Implement Incident Action Plan in coordination with the On-Site Group Supervisor.
<input type="checkbox"/>	Review ignition procedures.
<input type="checkbox"/>	Review ignition criteria.
<input type="checkbox"/>	Review flare gun manufacturer's loading instructions and specifications.
<input type="checkbox"/>	Prepare ignition equipment.
<input type="checkbox"/>	Review training of ignition team members.
Level 2	
<input type="checkbox"/>	Continue with previous actions.
<input type="checkbox"/>	Assemble an adequate ignition team, ideally containing four members but never fewer than two members so that there is at least one person for rescue backup.
<input type="checkbox"/>	Carry out pre-ignition planning.
<input type="checkbox"/>	Monitor the area for combustible gas.
<input type="checkbox"/>	Erect windsock and streamers if time permits.
<input type="checkbox"/>	If it is not an urgent situation and time permits, consultation with the On-Site Group Supervisor, Site Operations Section Chief, Incident Commander, CEOC Operations Chief and Regulatory authorities should be made regarding ignition.
Level 3	
<input type="checkbox"/>	Continue with previous actions.
<input type="checkbox"/>	Assemble an adequate ignition team, ideally containing four members but never with fewer than two members so that there is one person for rescue backup.
<input type="checkbox"/>	Carry out pre-ignition planning.
<input type="checkbox"/>	Monitor the area for combustible gas.
<input type="checkbox"/>	If time permits, consultation with the On-Site Group Supervisor, Site Operations Section Chief, Incident Commander, CEOC Operations Chief and Regulatory authorities should be made regarding ignition.

IGNITION TEAM LEADER

IGNITION TEAM LEADER	
IGNITION TEAM	Deactivation
	<input type="checkbox"/> Ensure all work areas, safety equipment, machinery and tools are cleaned, repaired and returned to their proper location.
	<input type="checkbox"/> Complete and submit all incident related documentation to the On-Site Group Supervisor.
	<input type="checkbox"/> Participate in the post-incident debriefing held by the Incident Commander.
	<input type="checkbox"/> Participate in any Critical Stress Incident Debriefing, as required.
Forms	
<input type="checkbox"/>	ICS 214 – Activity Log
<input type="checkbox"/>	Stakeholder Contact Record
<input type="checkbox"/>	Environmental Monitoring Record

3.7 Staging Area Manager

The Staging Area Manager oversees and controls the movement of equipment, services, and personnel at the staging area.

STAGING AREA MANAGER	
Location	
<input type="checkbox"/>	Location not pre-determined.
Takes Direction From	
<input type="checkbox"/>	Site Operations Section Chief.
Confers With	
<input type="checkbox"/>	On-Site Team.
Gives Direction To	
<input type="checkbox"/>	Contractors and suppliers.
Alert/Minor	
<input type="checkbox"/>	No assigned duties during an alert/minor.
Level 1	
<input type="checkbox"/>	Document all activities utilizing the ICS 214 – Activity Log.
<input type="checkbox"/>	Proactively review area map to identify potential staging areas near the incident site and outside of the EPZ.
<input type="checkbox"/>	Ensure potential staging area has an adequately sized site that is stable and level with suitable access roads.
<input type="checkbox"/>	Ensure potential staging area has no entry problems such as narrow approach ways, gates, power lines, etc.
<input type="checkbox"/>	Ensure potential staging area has adequate communication reception.
Level 2	
<input type="checkbox"/>	Continue with previous actions.
<input type="checkbox"/>	Ensure approval has been obtained from landowner.
<input type="checkbox"/>	Establish a staging area.
<input type="checkbox"/>	Erect staging area information and directional signs to the staging area, if required.
<input type="checkbox"/>	Flag the perimeter of the staging area.
<input type="checkbox"/>	Obtain an office trailer and emergency lighting, if required.
<input type="checkbox"/>	Advise the Site Operations Section Chief about the location and directions to the staging area.
<input type="checkbox"/>	Respond to Site Operations Section Chief's request for resources.
<input type="checkbox"/>	Coordinate and maintain a log of personnel and services.
<input type="checkbox"/>	Maintain a copy of the ICS 211 - Check-In List. Provide a completed copy of all resources that are available, in use, and out of service to the Site Operations Section Chief and CEOC Finance Chief. <i>Note: Out of Service resources should not be located at the Staging Area.</i>
Level 3	
<input type="checkbox"/>	Continue with previous actions.
<input type="checkbox"/>	Continue coordinating staging area operations support requirements until incident is concluded.
Deactivation	
<input type="checkbox"/>	Demobilize or move staging area in accordance with incident demobilization plan.
<input type="checkbox"/>	Remove all equipment and supplies and coordinate clean-up of the staging area.
<input type="checkbox"/>	Complete and submit all Staging Area documentation to the Site Operations Section Chief.
<input type="checkbox"/>	Participate in post-incident debriefing held by the Incident Commander.
<input type="checkbox"/>	Participate in any Critical Incident Stress Debriefing, as required.

STAGING AREA MANAGER

Forms	
<input type="checkbox"/>	ICS 211 – Check-In List
<input type="checkbox"/>	ICS 214 – Activity Log
<input type="checkbox"/>	ICS 234 – Work Analysis Matrix

3.8 Site Safety Officer

The role of the Site Safety Officer is to develop and recommend measures for assuring the safety of all personnel, as well as to assess and anticipate hazardous situations. The Site Safety Officer reviews the site Incident Action Plan for safety concerns and discontinues any operation which threatens the health and safety of responders.

SITE SAFETY OFFICER	
Location	
<input type="checkbox"/>	Incident Command Post.
Takes Direction From	
<input type="checkbox"/>	Incident Commander.
Confers With	
<input type="checkbox"/>	Section Chiefs.
<input type="checkbox"/>	Site Liaison Officers.
<input type="checkbox"/>	On Site Safety Team Lead
Gives Direction To	
<input type="checkbox"/>	Site Operations Section Chief.
<input type="checkbox"/>	On Site Safety Team lead
All Levels	
<input type="checkbox"/>	Document all activities utilizing the ICS 214 – Activity Log.
<input type="checkbox"/>	Continually evaluate risks and identify hazardous situations associated with the incident.
<input type="checkbox"/>	Assertively make safety concerns known to the Incident Commander.
<input type="checkbox"/>	Exercise emergency authority to stop and prevent unsafe acts.
<input type="checkbox"/>	Prepare ICS 215A – Incident Action Plan Safety Analysis. Collaborate with the On-Site Safety Team lead and Site Operations Section Chief in the development of the ICS 215A.
<input type="checkbox"/>	Instruct On-Site Safety Team lead to confirm all workers have required training before they are dispatched to the incident.
<input type="checkbox"/>	Prepare ICS 206 – Medical Plan for the operational period to be provided to all Command and General Staff as part of the Incident Action Plan (IAP).
<input type="checkbox"/>	Prepare ICS 208 - Safety Message/Plan for the operational period - can be included as part of the IAP.
<input type="checkbox"/>	Review the complete Incident Action Plan for safety implications.
<input type="checkbox"/>	Document safety message for operation period on the Incident Action Plan.
<input type="checkbox"/>	Conduct responder safety orientations, if required.
<input type="checkbox"/>	Ensure the proper use of personal protective equipment.
<input type="checkbox"/>	Ensure that responder personnel are taking appropriate actions; safe work procedures, proper grounding, bonding procedures, working in teams, etc.
<input type="checkbox"/>	Ensure workers who show signs of stress, fatigue or adverse symptoms are demobilized and sent for treatment if necessary.
<input type="checkbox"/>	Recommend alternatives for activities which are considered to be unsafe.
<input type="checkbox"/>	Ensure incident casualties receive first aid and ongoing care.
<input type="checkbox"/>	If any serious injuries occur, ensure the incident scene remains undisturbed, if possible, until there has been a thorough investigation.
<input type="checkbox"/>	Investigate accidents that have occurred within the incident area.
<input type="checkbox"/>	Document all injuries and on-site medical treatments.
<input type="checkbox"/>	Review and approve the medical plan if implemented.
<input type="checkbox"/>	Ensure safe and adequate lighting is in place as required.
<input type="checkbox"/>	Ensure only intrinsically safe radios are used in the incident area.
<input type="checkbox"/>	Ensure that nobody, including contract personnel, works alone.
<input type="checkbox"/>	Participate in planning meetings.
<input type="checkbox"/>	Continue to follow up and maintain safety responsibilities.

SITE SAFETY OFFICER

SITE SAFETY OFFICER	
SITE SAFETY	Deactivation
	<input type="checkbox"/> Participate in the post-incident debriefing held by the Incident Commander.
	<input type="checkbox"/> Complete and submit all incident related documentation to the Incident Commander
	<input type="checkbox"/> Participate in the Critical Incident Stress Debriefing as required.

Forms	
<input type="checkbox"/>	ICS 206 – Medical Plan
<input type="checkbox"/>	ICS 208 – Safety Message/Plan
<input type="checkbox"/>	ICS 214 – Activity Log
<input type="checkbox"/>	ICS 215A – Incident Action Plan Safety Analysis

3.9 Site Liaison Officer

The Site Liaison Officer interfaces with government agency representatives. The objective of the Site Liaison Officer is to ensure there is collaborative communication with the government agency representatives and to report communications to the Incident Commander.

SITE LIAISON OFFICER	
Location	
<input type="checkbox"/>	Incident Command Post.
<input type="checkbox"/>	Government Emergency Operations Centre (Level 2 and 3).
Takes Direction From	
<input type="checkbox"/>	Incident Commander.
Confers With	
<input type="checkbox"/>	Section Chiefs.
<input type="checkbox"/>	Site Safety Officer.
All Levels	
<input type="checkbox"/>	Document all activities utilizing the ICS 214 – Activity Log.
<input type="checkbox"/>	Receive briefing from Incident Commander.
<input type="checkbox"/>	Evaluate which government agencies have jurisdiction for the type of incident and inside the planning zone.
<input type="checkbox"/>	When requested by the Incident Commander, take measures to request a closure order of the EPZ.
<input type="checkbox"/>	Notify RCMP, local police and/or local authority to inform them of the location of roadblocks. The authority contacted will be dependent on whether the roadway is a numbered highway, urban roadway, or rural road. Provide them with sufficient information regarding the incident and allow them to determine if they choose to take control of the roadblock.
<input type="checkbox"/>	Confirm RCMP road closures for primary highways, secondary roadways, and HAZMAT incidents. Final approval and notification must be completed by the Incident Commander.
<input type="checkbox"/>	In coordination with the Incident Commander, complete Regulatory Authority notification according to the applicable requirements.
<input type="checkbox"/>	Review Section 11.1 Jurisdictional Forms to determine required written notifications. Ensure jurisdictional forms are completed and submitted.
<input type="checkbox"/>	Refer to the Notification Requirements for Key Government Agencies and Resources in the Jurisdictional section of this document. (see Section 9.0)
<input type="checkbox"/>	Determine which government and regulatory notifications have been completed.
<input type="checkbox"/>	Receive representatives from the Regulatory Authority, the local authority and local regional health authority at the Incident Command Post.
<input type="checkbox"/>	Coordinate the flow of information to and from the government agencies. or appoint a representative to
<input type="checkbox"/>	Update the Incident Commander.
<input type="checkbox"/>	Travel to or appoint a representative to the Government Emergency Operations Centre, if necessary.
Deactivation	
<input type="checkbox"/>	Ensure any agency communications initiated during the emergency, are revisited and communicate call down.
<input type="checkbox"/>	Complete and submit all incident related documentation to the Incident Commander
<input type="checkbox"/>	Participate in post-incident debriefing held by Incident Commander.
<input type="checkbox"/>	Participate in the Critical Incident Stress Debriefing as required.

SITE LIAISON OFFICER

Forms	
<input type="checkbox"/>	ICS 214 – Activity Log
<input type="checkbox"/>	ICS 234 – Work Analysis Matrix
<input type="checkbox"/>	Section 11.0 Jurisdictional Forms, as required
<input type="checkbox"/>	Status Board

3.10 Site Scribe

The Site Scribe provides documentation and administrative assistance to the Incident Command Post. This includes the recording of meeting minutes, information filing, and reproduction tasks. If required, a Site Scribe may be assigned to solely maintain a written record of the incident response.

SITE SCRIBE	
Location	
<input type="checkbox"/>	Incident Command Post.
Takes Direction From	
<input type="checkbox"/>	Incident Commander.
<input type="checkbox"/>	Site Planning Section Chief
All Levels	
<input type="checkbox"/>	Document all activities utilizing the ICS 214 – Activity Log.
<input type="checkbox"/>	Maintain a chronological summary of the incident response activities.
<input type="checkbox"/>	Record names of personnel in each assigned response position and their location utilizing ICS 211 – Check-In List and ICS 207 – Incident Organization Chart.
<input type="checkbox"/>	Record control and containment measures.
<input type="checkbox"/>	Record environmental monitoring information.
<input type="checkbox"/>	Record injuries, deaths, and missing persons.
<input type="checkbox"/>	Record phone calls.
<input type="checkbox"/>	Record decisions.
<input type="checkbox"/>	Record actions.
<input type="checkbox"/>	Record status of the public protection actions.
<input type="checkbox"/>	Collect documentation from response team members.
<input type="checkbox"/>	Maintain a consistent system for organizing the data.
<input type="checkbox"/>	As needed, photograph and post information for response team members to see.
Deactivation	
<input type="checkbox"/>	Participate in the post-incident debriefing held by the Incident Commander.
<input type="checkbox"/>	Gather and forward all incident related documentation from the Incident Command Post to the Planning Section.
<input type="checkbox"/>	Participate in the Critical Incident Stress Debriefing as required.

SITE SCRIBE

Forms	
<input type="checkbox"/>	ICS 207 – Incident Organization Chart (may be completed by Site Planning Section Chief, if assigned)
<input type="checkbox"/>	ICS 211 – Check-In List
<input type="checkbox"/>	ICS 214 – Activity Log
<input type="checkbox"/>	Environmental Monitoring Record
<input type="checkbox"/>	ICS 234 – Work Analysis Matrix
<input type="checkbox"/>	Status Board

3.11 Site Planning Section Chief

The Site Planning Section Chief is responsible for strategic planning, evaluating and processing information for use in the development of the Incident Action Plan. Disseminating information can be in the form of the Incident Action Plan, formal briefings, or status board displays.

SITE PLANNING SECTION CHIEF	
Location	
<input type="checkbox"/>	Incident Command Post.
Takes Direction From	
<input type="checkbox"/>	Incident Commander.
Confers With	
<input type="checkbox"/>	Section Chiefs.
<input type="checkbox"/>	Liaison.
<input type="checkbox"/>	Site Safety Officer.
Gives Direction To	
<input type="checkbox"/>	Planning Section
<input type="checkbox"/>	Section Chiefs.
All Levels	
<input type="checkbox"/>	Document all activities utilizing the ICS 214 – Activity Log.
<input type="checkbox"/>	Prepare the ICS 202 – Incident Objectives Form following each Command and General Staff Meeting. Obtain sign-off from Incident Commander prior to dissemination as part of the Incident Action Plan.
<input type="checkbox"/>	Prepare for the Planning Meeting, Review ICS 215 – Operational Planning Worksheet developed in the Tactics Meeting. Review ICS 215A – Incident Action Plan Safety Analysis prepared by the Site Safety Officer.
<input type="checkbox"/>	Assess current operations effectiveness and resource efficiency and gather information to support incident management decisions.
<input type="checkbox"/>	Facilitate Planning Meeting with Command and General Staff. Review. Validate the operational plan as proposed by the Site Operations Section Chief.
<input type="checkbox"/>	Prepare the ICS 203 – Organization Assignment List with information on all positions currently activated, include the names of personnel assigned to each position. ICS 203 serves as part of the Incident Action Plan.
<input type="checkbox"/>	Prepare the Incident Action Plan when requested by the Incident Commander.
<input type="checkbox"/>	Distribute Incident Action Plan to the Incident Commander for approval prior to disseminating to Command and General Staff.
<input type="checkbox"/>	Assess the current situation and prepare an incident response strategy considering “what if” scenarios.
<input type="checkbox"/>	Assemble information and propose alternative strategies.
<input type="checkbox"/>	Compile and display incident information on the Status Board.
<input type="checkbox"/>	Using the information contained within the ICS 203 – Organization Assignment List, continuously monitor and update ICS 207 – Incident Organization Chart.
<input type="checkbox"/>	In a prolonged incident, ensure site response strategies are considered. Develop the ICS 209 – Incident Status Summary as required.
<input type="checkbox"/>	Consider and appoint appropriate personnel to develop a safe, efficient effective re-entry plan for evacuees.
Deactivation	
<input type="checkbox"/>	Develop plan for demobilization. Utilize ICS 221 – Demobilization Check-Out Form.
<input type="checkbox"/>	Gather and forward all incident related documentation from the Planning Section to the Incident Commander
<input type="checkbox"/>	Participate in the post-incident debriefing held by the Incident Commander.
<input type="checkbox"/>	In coordination with the Incident Commander prepare post incident reports & after incident action reports. Ensure all documentation is securely filed.
<input type="checkbox"/>	Participate in the Critical Incident Stress Debriefing as required.

SITE PLANNING SECTION CHIEF

Forms	
<input type="checkbox"/>	ICS 202 – Incident Objectives
<input type="checkbox"/>	ICS 203 – Organization Assignment List
<input type="checkbox"/>	ICS 207 – Incident Organization Chart
<input type="checkbox"/>	ICS 209 – Incident Status Summary (to be completed following a significant incident)
<input type="checkbox"/>	ICS 214 – Activity Log
<input type="checkbox"/>	ICS 221 – Demobilization Check-Out
<input type="checkbox"/>	ICS 230 – Daily Meeting Schedule

3.12 Site Logistics Section Chief

The Site Logistics Section Chief assists the response effort by procuring equipment and support services.

SITE LOGISTICS SECTION CHIEF	
Location	
<input type="checkbox"/>	Incident Command Post.
Takes Direction From	
<input type="checkbox"/>	Incident Commander.
Confers With	
<input type="checkbox"/>	Section Chiefs.
<input type="checkbox"/>	Site Liaison Officer
<input type="checkbox"/>	Site Safety Officer.
Gives Direction To	
<input type="checkbox"/>	Site Section Chiefs.
All Levels	
<input type="checkbox"/>	Document all activities utilizing the ICS 214 – Activity Log.
<input type="checkbox"/>	Develop and implement Incident Action Plan in coordination with the Section Chiefs and Incident Commander.
<input type="checkbox"/>	Procure supplies.
<input type="checkbox"/>	Procure transportation services.
<input type="checkbox"/>	Procure equipment.
<input type="checkbox"/>	Procure manpower.
<input type="checkbox"/>	Procure communications systems.
<input type="checkbox"/>	Procure oil spill contractor/cooperative services.
<input type="checkbox"/>	Procure catering services for the responders.
<input type="checkbox"/>	In a prolonged incident, identify and obtain accommodations for responders.
Deactivation	
<input type="checkbox"/>	Notify all services and suppliers of the stand-down of the incident.
<input type="checkbox"/>	Gather and forward all incident related documentation from the Logistics Section to the Incident Commander.
<input type="checkbox"/>	Participate in the post-incident debriefing held by the Incident Commander.
<input type="checkbox"/>	Participate in the Critical Incident Stress Debriefing as required.
SITE LOGISTICS SECTION CHIEF	
Forms	
<input type="checkbox"/>	ICS 214 – Activity Log
<input type="checkbox"/>	ICS 234 – Work Analysis Matrix

3.13 Site Admin/Finance Section Chief

The Site Admin/Finance Section Chief is responsible for tracking cost, time compensation and claims. This role, when filled by field personnel, is to provide financial administrative support to the CEOC.

SITE ADMIN/FINANCE SECTION CHIEF	
Location	
<input type="checkbox"/>	Incident Command Post.
Takes Direction From	
<input type="checkbox"/>	Incident Commander.
Confers With	
<input type="checkbox"/>	Section Chiefs.
<input type="checkbox"/>	Site Liaison Officer
<input type="checkbox"/>	Site Safety Officer.
All Levels	
<input type="checkbox"/>	Document all activities utilizing the ICS 214 – Activity Log.
<input type="checkbox"/>	Obtain briefings from the Incident Commander.
<input type="checkbox"/>	Account for costs.
<input type="checkbox"/>	Track time.
<input type="checkbox"/>	Assist response team with expedient payment for “out of pocket” expenses as a result of the incident for evacuees.
<input type="checkbox"/>	Adhere to procurement procedures. Assist Section Chief with contracts for new support services as required
<input type="checkbox"/>	Track compensation and claims.
<input type="checkbox"/>	Attend planning meetings.
<input type="checkbox"/>	Submit reports and expense claims to the CEOC Financial Department.
Deactivation	
<input type="checkbox"/>	Participate in the post-incident debriefing held by the Incident Commander.
<input type="checkbox"/>	Gather and forward all incident related documentation from the Admin/Finance Section for to the Incident Commander
<input type="checkbox"/>	Participate in the Critical Incident Stress Debriefing as required.

SITE ADMIN/FINANCE SECTION CHIEF

Forms	
<input type="checkbox"/>	ICS 214 – Activity Log
<input type="checkbox"/>	Evacuee Expense Claim Form

4.0 **CEOC INCIDENT COMMAND STRUCTURE - ROLES AND RESPONSIBILITIES**

4.1 CEOC Command Chart

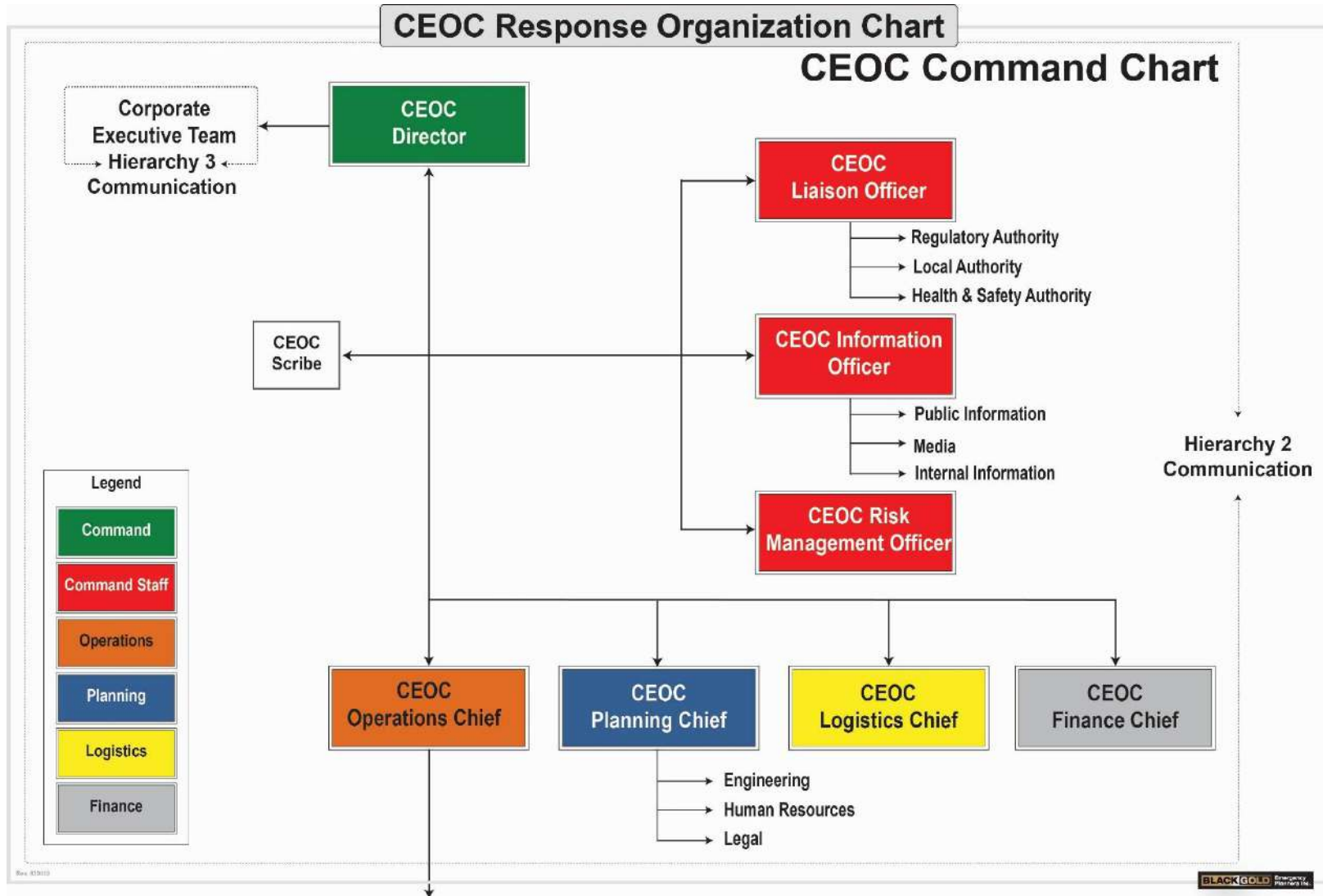

4.2 CEOC Director

The CEOC Director provides advice and support to the CEOC Chiefs. The CEOC Director provides overall policy direction and has the final decision authority.

CEOC DIRECTOR	
Location	
<input type="checkbox"/>	Corporate Emergency Operations Centre.
Confers With	
<input type="checkbox"/>	Corporate Executive Team.
Gives Direction To	
<input type="checkbox"/>	CEOC Chiefs.
<input type="checkbox"/>	CEOC Liaison Officer.
<input type="checkbox"/>	CEOC Risk Management Officer.
<input type="checkbox"/>	CEOC Information Officer.
All Levels	
<input type="checkbox"/>	Document all activities utilizing the ICS 214 – Activity Log.
<input type="checkbox"/>	Advise the Corporate Executive Team.
<input type="checkbox"/>	In consultation with the CEOC Operations Chief, develop and implement a comprehensive response plan for the incident.
<input type="checkbox"/>	Evaluate the CEOC Operations Chief's actions.
<input type="checkbox"/>	Make CEOC Operations Chief aware of external expertise and services that can be provided.
<input type="checkbox"/>	Ensure personnel and expertise from Engineering, Human Resources and Legal are available as required to support the incident response activities.
<input type="checkbox"/>	Confirm the status of the incident.
<input type="checkbox"/>	Estimate the maximum impact and duration of the incident.
<input type="checkbox"/>	Determine the impact on the public.
<input type="checkbox"/>	Determine business continuity issues.
<input type="checkbox"/>	Advise on corporate responsibilities.
<input type="checkbox"/>	Advise on any internal company policies.
<input type="checkbox"/>	Identify agencies (government and regulatory) with jurisdiction related to the incident.
<input type="checkbox"/>	If incident escalates ensure that the CEOC Liaison Officer role is filled.
<input type="checkbox"/>	Ensure that CEOC Liaison Officer is coordinating communication between government agencies and company personnel as required.
<input type="checkbox"/>	Ensure ongoing internal communication, as appropriate.
<input type="checkbox"/>	Approve major capital financial support as required.
<input type="checkbox"/>	Advise and support the CEOC Information Officer regarding media and public statements.
Deactivation	
<input type="checkbox"/>	Ensure the CEOC Liaison Officer, in coordination with the Regulatory Authority and Incident Commander, agree that there is consensus to downgrade the level of emergency.
<input type="checkbox"/>	Ensure the CEOC Liaison Officer has notified all previously contacted government agencies of the decision to downgrade the emergency.
<input type="checkbox"/>	Ensure all records and reports are gathered in their original state for accurate post-incident review. Provide all incident related documentation to the CEOC Planning Chief.
<input type="checkbox"/>	Ensure all CEOC Team Members are notified.
<input type="checkbox"/>	Participate in the post-incident debriefing held by the Incident Commander.
<input type="checkbox"/>	Participate in the Critical Incident Stress Debriefing as required.
<input type="checkbox"/>	Approve final release of incident reports in coordination with the legal department.

CEOC DIRECTOR

Forms	
<input type="checkbox"/>	ICS 214 – Activity Log.

4.3 CEOC Operations Chief

The CEOC Operations Chief is the main link between the Incident Command Post, the Corporate Emergency Operations Centre and is the main informant for the CEOC Director. The CEOC Operations Chief speaks directly with the Incident Commander.

The CEOC Operations Chief provides operational, public safety, planning and logistics advice and support to assist the Incident Commander with developing an effective field Incident Action Plan (IAP).

CEOC OPERATIONS CHIEF	
Location	Corporate Emergency Operations Centre.
Takes Direction From	<input type="checkbox"/> CEOC Director.
Confers With	<input type="checkbox"/> CEOC Chiefs. <input type="checkbox"/> CEOC Liaison Officer. <input type="checkbox"/> CEOC Risk Management Officer. <input type="checkbox"/> CEOC Information Officer.
Gives Direction To	<input type="checkbox"/> Incident Commander.
All Levels	<input type="checkbox"/> Document all activities utilizing the ICS 214 – Activity Log. <input type="checkbox"/> Establish method of communications with the Incident Commander. <input type="checkbox"/> Schedule regular briefings with the Incident Commander. <input type="checkbox"/> Dedicate a phone line to the Incident Commander. <input type="checkbox"/> Confer with the Incident Commander to ascertain the level of emergency. <input type="checkbox"/> Activate the CEOC. <input type="checkbox"/> Appoint CEOC team members. <input type="checkbox"/> Complete the CEOC team and site command team assignment charts. <input type="checkbox"/> Schedule regular briefings with the CEOC team members and clarify objectives as necessary. <input type="checkbox"/> Ensure the Status Board and ICS 234 - Work Analysis Matrix are prominently displayed in the CEOC. <input type="checkbox"/> Develop Incident Action Plan in coordination with the CEOC team members and Incident Commander. <input type="checkbox"/> Ensure public protection and responder safety issues are being addressed. <input type="checkbox"/> Discuss actions with the Incident Commander and provide support until situation is normalized. <input type="checkbox"/> Verify the boundaries of the emergency response planning zones. <input type="checkbox"/> Discuss shelter and/or evacuation plan, as required. <input type="checkbox"/> Discuss transient surveys plan, as required. <input type="checkbox"/> Discuss mobile air quality monitoring plan, as required. <input type="checkbox"/> Discuss the area isolation and roadblock plan, as required. <input type="checkbox"/> Discuss NOTAM (Notice to Airmen) if necessary. <input type="checkbox"/> Verify that adequate containment and recovery measures are initiated. <input type="checkbox"/> Evaluate which government agencies have jurisdiction inside the emergency response zones. <input type="checkbox"/> In coordination with the Incident Commander, ensure Regulatory Authority notification according to the applicable requirements. <input type="checkbox"/> Refer to the Notification Requirements for Key Government Agencies and Resources in the Jurisdictional section of this document. <input type="checkbox"/> Designate CEOC Liaison Officer and direct them to communicate with the Site Liaison Officer to ensure coordinated notifications are received to the Regulatory Authority, environmental agency, health authority, local authority, Police, occupational health and safety authority and pressure vessel authority contact. <input type="checkbox"/> Ensure Regulatory Authority notification according to the applicable requirements. <input type="checkbox"/> Ensure the applicable reporting form has been completed and submitted to the applicable Regulatory Authority.

CEOC OPERATIONS CHIEF

CEOC OPERATIONS CHIEF		
CEOC OPERATIONS CHIEF	<input type="checkbox"/> Ensure confirmation of the level of emergency with Regulatory Authority.	
	<input type="checkbox"/> Ensure the notification of the applicable Regulatory Authority if the public or media has been contacted.	
	<input type="checkbox"/> Evaluate ignition criteria and communicate with the Incident Commander and applicable Regulatory Authority regarding ignition decision.	
	<input type="checkbox"/> Ensure other required government authorities have been notified (e.g. environmental agency, local health authority, local authority, occupational health and safety authority and pressure vessel authority).	
	<input type="checkbox"/> Ensure monitoring data is being provided to the appropriate regulatory agencies via the Site Liaison Officer and CEOC Liaison Officer.	
	<input type="checkbox"/> Assess the potential for media interest and the need to notify the CEOC Information Officer.	
	<input type="checkbox"/> Direct media communication to CEOC Information Officer.	
	<input type="checkbox"/> Ensure communication with all previously contacted agencies is maintained throughout the incident duration at set frequencies, until the incident is downgraded.	
	<input type="checkbox"/> Assess corporate responsibility with regards to health, environment, community, and business impacts including joint venture partner notification.	
	<input type="checkbox"/> Keep the CEOC Director and Corporate Executive Team advised of ongoing events.	
	<input type="checkbox"/> Discuss business continuity concerns with CEOC Director.	
	<input type="checkbox"/> Assess the incident situation with regards to both short and long-term implications.	
	<input type="checkbox"/> For prolonged incidents, ensure provisions for relieving and rotating staff on a regular basis.	
	Deactivation	
	<input type="checkbox"/> In consultation with the Incident Commander and the applicable Regulatory Authority, downgrade the emergency.	
	<input type="checkbox"/> In consultation with the applicable Regulatory Authority, ensure the NOTAM is lifted, if necessary.	
	<input type="checkbox"/> Ensure all appropriate agencies previously notified of the emergency are notified of the stand-down of the emergency.	
	<input type="checkbox"/> Ensure all evacuees are notified of the stand-down of the emergency.	
	<input type="checkbox"/> In consultation with the CEOC Information Officer, ensure the media is notified of the stand-down of emergency.	
	<input type="checkbox"/> Confirm with the Incident Commander that all evacuees are being assisted in returning to their residences/businesses.	
	<input type="checkbox"/> Ensure follow-up meetings are held with affected residents/landowners.	
	<input type="checkbox"/> Ensure all, incident related documentation From the CEOC Operations Section is collected and provided to the Planning Section.	
	<input type="checkbox"/> Participate in the post-incident debriefing held by the Incident Commander.	
	<input type="checkbox"/> Ensure Critical Incident Stress Debriefing for responders is coordinated by the Human Resources Department.	
	<input type="checkbox"/> Participate in any Critical Incident Stress Debriefing.	

Forms	
<input type="checkbox"/>	ICS 214 – Activity Log
<input type="checkbox"/>	ICS 234 – Work Analysis Matrix
<input type="checkbox"/>	Notification Record
<input type="checkbox"/>	Status Board

4.4 CEOC Liaison Officer

The CEOC Liaison Officer assists the Information Officer with the interface with government agencies to determine their response capabilities at the time of the incident and to provide incident status reports. The mandate of the CEOC Liaison Officer is to support the Information Officer and develop an integrated response to the incident with the Regulatory Authority and Government Agencies.

CEOC LIAISON OFFICER	
Location	
<input type="checkbox"/>	Corporate Emergency Operations Centre.
<input type="checkbox"/>	Government Emergency Operations Centre (Level 2 and 3).
Takes Direction From	
<input type="checkbox"/>	CEOC Director.
Confers With	
<input type="checkbox"/>	CEOC Chiefs.
<input type="checkbox"/>	CEOC Information Officer.
<input type="checkbox"/>	CEOC Risk Management Officer.
All Levels	
<input type="checkbox"/>	Document all activities utilizing the ICS 214 – Activity Log.
<input type="checkbox"/>	Receive briefing from CEOC Operations Chief.
<input type="checkbox"/>	Establish Communication and work with the Site Liaison Officer. Work in coordination with Site Liaison Officer.
<input type="checkbox"/>	Evaluate which government agencies have jurisdiction inside the planning zone and response zones.
<input type="checkbox"/>	When requested by the Incident Commander, take measures to request a closure order of the EPZ.
<input type="checkbox"/>	Notify RCMP, local police and/or local authority to inform them of the location of roadblocks. The authority contacted will be dependent on whether the roadway is a numbered highway, urban roadway, or rural road. Provide them with sufficient information regarding the incident and allow them to determine if they choose to take control of the roadblock.
<input type="checkbox"/>	Confirm RCMP road closures for primary highways, secondary roadways, and HAZMAT incidents. Final approval and notification must be completed by the Incident Commander.
<input type="checkbox"/>	In coordination with the CEOC Operations Chief and Site Liaison Officer ensure Regulatory Authority notification is completed according to the applicable requirements.
<input type="checkbox"/>	Refer to the Notification Requirements for Key Government Agencies and Resources in the Jurisdictional section of this document.
<input type="checkbox"/>	Determine which government and regulatory notifications have been completed.
<input type="checkbox"/>	Develop a communication strategy with those government agencies who need to be contacted.
<input type="checkbox"/>	Address inquiries from and obtain information required by the government agencies.
<input type="checkbox"/>	Fill out and submit the forms as provided by the applicable government and/or Regulatory Authority.
<input type="checkbox"/>	Coordinate the flow of communication to and from the government agencies.
<input type="checkbox"/>	Coordinate the use of expertise and resources available through the government agencies.
<input type="checkbox"/>	Ensure a delegated representative attends the Government Emergency Operations Centre, if established.
<input type="checkbox"/>	Update all previous contacts of change in status.
Deactivation	
<input type="checkbox"/>	In coordination with the Regulatory Authority ensure that there is consensus to downgrade the emergency.
<input type="checkbox"/>	Notify all previously contacted government agencies of the decision to downgrade the emergency.
<input type="checkbox"/>	Gather all incident related documentation from the CEOC Liaison team. Coordinate data and documentation with the Site Liaison Officer and ensure all documentation is submitted to the Planning Section.
<input type="checkbox"/>	Participate in post-incident debriefing held by Incident Commander.
<input type="checkbox"/>	Participate in the Critical Incident Stress Debriefing as required.

CEOC LIAISON OFFICER

Forms	
<input type="checkbox"/>	ICS 214 – Activity Log
<input type="checkbox"/>	ICS 234 – Work Analysis Matrix
<input type="checkbox"/>	Government/Regulatory Reporting Form
<input type="checkbox"/>	Status Board

4.5 CEOC Information Officer

The CEOC Information Officer will develop a communication strategy to ensure information and releases are appropriate, consistent, accurate, and timely. The CEOC Information Officer implements the communication plan, providing media information support and serving as the dissemination point for all media releases.

The CEOC Information Officer ensures the affected public receives ongoing information about emergency status, relief programs, and services.

CEOC INFORMATION OFFICER	
Location	
<input type="checkbox"/>	Corporate Emergency Operations Centre.
Takes Direction From	
<input type="checkbox"/>	CEOC Director.
Confers With	
<input type="checkbox"/>	CEOC Chiefs.
<input type="checkbox"/>	CEOC Liaison Officer.
<input type="checkbox"/>	CEOC Risk Management Officer.
All Levels	
<input type="checkbox"/>	Document all activities utilizing the ICS 214 – Activity Log.
<input type="checkbox"/>	Prepare telephone response for Company receptionists.
<input type="checkbox"/>	Contact the Emergency 24-hour number attendant, if applicable and/or the Company Field Office to ensure all media enquiries are directed to the CEOC Information Officer.
<input type="checkbox"/>	Monitor communication issues and incorporate into communications plan.
<input type="checkbox"/>	Ensure communication channels are established and maintained with appropriate stakeholders.
<input type="checkbox"/>	Assess media impacts and ensure concerns are clearly identified.
<input type="checkbox"/>	Prepare all media responses with the assistance of the CEOC Director.
<input type="checkbox"/>	Establish media notification schedules.
<input type="checkbox"/>	Ensure all media releases are approved by the Incident Commander and coordinated with the applicable Regulatory Authority prior to release, if/when possible.
<input type="checkbox"/>	Organize news conferences.
<input type="checkbox"/>	Dispatch personnel to field locations, media information centres and/or Government Emergency Operations Centre, if applicable.
<input type="checkbox"/>	Ensure all other external requests are redirected to the appropriate recipient.
<input type="checkbox"/>	Prepare Reception Centre messaging as required. Ensure Reception Centre team has a current approved Incident Status Update Form . Ensure all messages and releases are posted in the Reception Centre.
<input type="checkbox"/>	Ensure Public Protection Team is disseminating the appropriate messages at the appropriate time during the emergency. <ul style="list-style-type: none"> - 6.11.1 General Evacuation Script - 6.11.2 Shelter in Place Script - 6.11.3 Urgent Evacuation Script - 6.11.4 Notification Script Section 10.5 Notice of Evacuation placards
Deactivation	
<input type="checkbox"/>	If required, continue media and public interaction.
<input type="checkbox"/>	Upon direction from the CEOC Liaison Officer and in coordination with the Regulatory Authority, prepare a media statement regarding the downgrade of the emergency if required.
<input type="checkbox"/>	Gather all incident related documentation from the CEOC Information Team and ensure all documentation is provided to the Planning Section.
<input type="checkbox"/>	Participate in post-incident debriefing held by Incident Commander.
<input type="checkbox"/>	Participate in the Critical Incident Stress Debriefing as required.

CEOC INFORMATION OFFICER

Forms	
<input type="checkbox"/>	ICS 214 – Activity Log
<input type="checkbox"/>	ICS 234 – Work Analysis Matrix

Use this template following the onset of an incident.

EMERGENCY COMMUNICATION PLANNING TEMPLATE	
EMERGENCY COMMUNICATION PLANNING TEMPLATE	<input type="checkbox"/> Identify the Communication Team.
	<input type="checkbox"/> Activate Communication Team.
	<input type="checkbox"/> Communication Team meets to assess the situation and develop communication strategies
	<input type="checkbox"/> CEOC Information Officer meets with CEOC Director to determine the response and message.
	<input type="checkbox"/> Communication Team prepares initial internal and external communication statements.
	<input type="checkbox"/> Ensure communication statements and strategy are reviewed and approved by CEOC Director.
	<input type="checkbox"/> CEOC Information Officer delivers initial internal and external messages in coordination with the applicable Regulatory Authority.
	<input type="checkbox"/> Communication Team updates company website information regarding the emergency.
	<input type="checkbox"/> Communication Team coordinates meetings with media and delivers approved messages.
	<input type="checkbox"/> Communication Team obtains regular status reports from CEOC Director.
	<input type="checkbox"/> Communication Team prepares and distributes status reports regularly on the communication situation.
	<input type="checkbox"/> Communication Team prepares and delivers regular updates to stakeholders, government agencies and other relevant entities.
	<input type="checkbox"/> Communication Team prepares and delivers messages on resolution of the emergency.
	<input type="checkbox"/> Communication Team provides ongoing updates to internal and external parties as the situation is resolved.
	<input type="checkbox"/> Communication Team is advised by CEOC Director that the emergency is over.
	<input type="checkbox"/> Communication Team stands down once the emergency has been resolved.
	<input type="checkbox"/> Communication Team prepares, and issues post-incident reports as needed to internal and external parties.
	<input type="checkbox"/> Communication Team conducts post-incident review of and revision to the Crisis Communication Plan.

4.6 CEOC Risk Management Officer

The CEOC Risk Management Officer takes into consideration events that have the potential to impact the Company's operations and business continuity. He/she identifies appropriate strategies to mitigate the risks.

CEOC RISK MANAGEMENT OFFICER	
Location	
<input type="checkbox"/>	Corporate Emergency Operations Centre.
Takes Direction From	
<input type="checkbox"/>	CEOC Director.
Confers With	
<input type="checkbox"/>	CEOC Chiefs.
<input type="checkbox"/>	CEOC Liaison Officer.
<input type="checkbox"/>	CEOC Information Officer.
All Levels	
<input type="checkbox"/>	Document all activities utilizing the ICS 214 – Activity Log.
<input type="checkbox"/>	Review the Incident Action Plan for risk management implications.
<input type="checkbox"/>	Determine the severity and impact of business interruption to the company; loss of service, supply chain interruptions, catastrophic loss of critical infrastructure, etc.
<input type="checkbox"/>	Establish which critical services/functions may be required for the response to the emergency.
<input type="checkbox"/>	Identify the critical functions that need to be reinstated within 24-hours or are time-dependent; IT recovery, supply chain, procurement, vendors, etc.
<input type="checkbox"/>	Aim to maintain the Company's minimum level of service.
Deactivation	
<input type="checkbox"/>	Implement business/disaster/IT recovery procedures.
<input type="checkbox"/>	Acquire the additional resources necessary for restoring business operations.
<input type="checkbox"/>	Gather all incident related documentation from the CEOC Risk Management Team and ensure all documentation is provided to the Planning Section.
<input type="checkbox"/>	Participate in the post-incident debriefing held by the Incident Commander.
<input type="checkbox"/>	Participate in the Critical Incident Stress Debriefing if required.

CEOC RISK MANAGEMENT OFFICER

Forms	
<input type="checkbox"/>	ICS 214 – Activity Log
<input type="checkbox"/>	ICS 234 – Work Analysis Matrix

4.7 CEOC Planning Chief

The CEOC Planning Chief leads the incident action planning process, typically thinking 12 to 36 hours in advance. He/she advises and supports the CEOC Operations Chief regarding technical assistance required for the response. The CEOC Planning Chief anticipates what actions need to be taken and recommends priorities to allocate corporate resources.

Note: The Site Planning Section Chief responsibilities may be allocated to CEOC Planning Chief dependent on the emergency level. See Site Planning Section Chief role in the previous section.

CEOC PLANNING CHIEF	
Location	
<input type="checkbox"/>	Corporate Emergency Operations Centre.
Takes Direction From	
<input type="checkbox"/>	CEOC Director.
Confers With	
<input type="checkbox"/>	CEOC Chiefs.
<input type="checkbox"/>	CEOC Liaison Officer.
<input type="checkbox"/>	CEOC Risk Management Officer.
<input type="checkbox"/>	CEOC Information Officer.
All Levels	
<input type="checkbox"/>	Document all activities utilizing the ICS 214 – Activity Log.
<input type="checkbox"/>	Assess the current situation and prepare an incident response strategy considering 'what if' scenarios.
<input type="checkbox"/>	Develop and implement Incident Action Plan.
<input type="checkbox"/>	Gather specialists (Human Resources, Engineering, Environmental, or Legal) required for the response.
<input type="checkbox"/>	Ensure incident information is documented, current and disseminated to the CEOC.
<input type="checkbox"/>	Utilize the Status Board, ICS 234 – Work Analysis Matrix and Response Organizational Chart.
<input type="checkbox"/>	Review the degree of success of the previous actions.
<input type="checkbox"/>	Post charts, plot plans, surveys, and maps as they are developed.
<input type="checkbox"/>	In a prolonged incident, ensure corporate response strategies are considered.
<input type="checkbox"/>	Notify and assemble replacement personnel if the incident lasts longer than 24-hours.
Deactivation	
<input type="checkbox"/>	Compile the overall post-incident action plan.
<input type="checkbox"/>	Gather all incident related documentation from the CEOC Planning Section and ensure all documentation is submitted to the Site Planning Section Chief.
<input type="checkbox"/>	Participate in the post-incident debriefing held by the Incident Commander.
<input type="checkbox"/>	Participate in the Critical Incident Stress Debriefing as required.

CEOC PLANNING CHIEF

Forms	
<input type="checkbox"/>	ICS 202 – Incident Objectives
<input type="checkbox"/>	ICS 203 – Organization Assignment List
<input type="checkbox"/>	ICS 207 – Incident Organization Chart
<input type="checkbox"/>	ICS 209 – Incident Status Summary (to be completed following a significant incident)
<input type="checkbox"/>	ICS 214 – Activity Log
<input type="checkbox"/>	ICS 221 – Demobilization Check-Out
<input type="checkbox"/>	ICS 234 – Work Analysis Matrix
<input type="checkbox"/>	ICS 230 – Daily Meeting Schedule

4.7.1 Engineering

The Engineering representative is responsible for all technical supporting data (well files, diagrams, schematics, process flow diagrams, etc.) along with any other engineering support requested by the CEOC Operations Chief.

ENGINEERING	
Location	
<input type="checkbox"/>	Corporate Emergency Operations Centre.
Takes Direction From	
<input type="checkbox"/>	CEOC Planning Chief.
All Levels	
<input type="checkbox"/>	Document all activities utilizing the ICS 214 – Activity Log.
<input type="checkbox"/>	Gather the necessary information needed to resolve the emergency situation (down-hole diagrams, facility schematics, etc.).
<input type="checkbox"/>	Provide engineering analysis and recommend solutions.
<input type="checkbox"/>	Assist with the development of control and containment procedures.
Deactivation	
<input type="checkbox"/>	Gather all incident related documentation from the Engineering Team and ensure all documentation is submitted to the Planning Section.
<input type="checkbox"/>	Participate in the post-incident debriefing held by the Incident Commander.
<input type="checkbox"/>	Participate in the Critical Incident Stress Debriefing as required.
ENGINEERING	
Forms	
<input type="checkbox"/>	ICS 214 – Activity Log

4.7.2 Human Resources

The Human Resources representative is responsible for addressing employee inquiries and assisting individual employees affected by the incident.

HUMAN RESOURCES	
Location	
<input type="checkbox"/>	Corporate Emergency Operations Centre.
Takes Direction From	
<input type="checkbox"/>	CEOC Planning Chief.
All Levels	
<input type="checkbox"/>	Document all activities utilizing the ICS 214 – Activity Log.
<input type="checkbox"/>	Mobilize additional Human Resource staff as required.
<input type="checkbox"/>	Sort and compile information about insurance and benefits for affected employees.
<input type="checkbox"/>	As required, mobilize counsellors to provide Critical Incident Stress Debriefing to employees and families.
<input type="checkbox"/>	Clarify the nature and extent of injuries to any employees or contract personnel.
<input type="checkbox"/>	Coordinate next of kin notification by the police in the event of death.
<input type="checkbox"/>	Coordinate any follow up next of kin notification on behalf of the Company.
<input type="checkbox"/>	Ensure compliance with all regulations for employment and human resource issues.
Deactivation	
<input type="checkbox"/>	Gather all incident related documentation from the Human Resources Team and ensure all documentation is submitted to the Planning Section.
<input type="checkbox"/>	Participate in the post-incident debriefing held by the Incident Commander.
<input type="checkbox"/>	Coordinate Critical Incident Stress Debriefing as required.

HUMAN RESOURCES

Forms	
<input type="checkbox"/>	ICS 214 – Activity Log

4.7.3 Legal

The Legal representative will provide legal advice on response activities, documentation, and communication.

LEGAL	
Location	
<input type="checkbox"/>	Corporate Emergency Operations Centre.
Takes Direction From	
<input type="checkbox"/>	CEOC Planning Chief.
All Levels	
<input type="checkbox"/>	Document all activities utilizing the ICS 214 – Activity Log.
<input type="checkbox"/>	Council on legal matters.
<input type="checkbox"/>	Evaluate liability implications of the incident.
<input type="checkbox"/>	Ensure that proper documentation is gathered and preserved.
<input type="checkbox"/>	Assist with legal settlement activities.
<input type="checkbox"/>	Review press releases.
Deactivation	
<input type="checkbox"/>	Gather all incident related documentation from the Legal Team and ensure all documentation is submitted to the Planning Section.
<input type="checkbox"/>	Participate in the post-incident debriefing held by the Incident Commander.
<input type="checkbox"/>	Participate in the Critical Incident Stress Debriefing as required.
LEGAL	
Forms	
<input type="checkbox"/>	ICS 214 – Activity Log

4.8 CEOC Logistics Chief

The CEOC Logistics Chief provides response support to the various Command Centres. This includes ordering supplies, communications, equipment, and personnel to support the emergency response activities.

Note: The Site Logistics Section Chief role may be allocated to CEOC Logistics Chief dependent on the emergency level. See Site Logistics Section Chief role in the previous section.

CEOC LOGISTICS CHIEF	
Location	
<input type="checkbox"/>	Corporate Emergency Operations Centre.
Takes Direction From	
<input type="checkbox"/>	CEOC Director.
Confers With	
<input type="checkbox"/>	CEOC Chiefs.
<input type="checkbox"/>	CEOC Liaison Officer.
<input type="checkbox"/>	CEOC Risk Management Officer.
<input type="checkbox"/>	CEOC Information Officer.
All Levels	
<input type="checkbox"/>	Document all activities utilizing the ICS 214 – Activity Log.
<input type="checkbox"/>	Assemble assistants as required to contact and procure equipment and services for the Response Team.
<input type="checkbox"/>	Develop and implement Incident Action Plan in coordination with the CEOC Chiefs.
<input type="checkbox"/>	Procure materials.
<input type="checkbox"/>	Procure equipment.
<input type="checkbox"/>	Procure manpower.
<input type="checkbox"/>	Procure transportation.
<input type="checkbox"/>	Procure communications systems.
<input type="checkbox"/>	Procure catering services for the responders.
<input type="checkbox"/>	Procure spill services and contractors.
<input type="checkbox"/>	Procure information technology services and support.
<input type="checkbox"/>	Procure medical aid capabilities.
<input type="checkbox"/>	Procure lighting units.
<input type="checkbox"/>	Procure sleeping and sheltering areas.
<input type="checkbox"/>	Procure sanitation and showers.
<input type="checkbox"/>	Determine the maintenance workload requirements and timelines.
<input type="checkbox"/>	Analyze equipment readiness status.
Deactivation	
<input type="checkbox"/>	Notify all services and suppliers of the stand-down of the incident.
<input type="checkbox"/>	Coordinate equipment recovery and demobilization operations.
<input type="checkbox"/>	Gather all incident related documentation from the CEOC Logistics Team and ensure all documentation is submitted to the Planning Section.
<input type="checkbox"/>	Participate in the post-incident debriefing held by the Incident Commander.
<input type="checkbox"/>	Participate in the Critical Incident Stress Debriefing as required.

CEOC LOGISTICS CHIEF

Forms	
<input type="checkbox"/>	ICS 214 – Activity Log
<input type="checkbox"/>	ICS 234 – Work Analysis Matrix

4.9 CEOC Finance Chief

The CEOC Finance Chief is responsible for employee and contractor time tracking, procurement procedures, compensation claims and cost accounting.

Note: The Site Admin/Finance Section Chief role may be allocated to CEOC Finance Chief dependent on the emergency level. See Site Admin/Finance Section Chief role in the previous section.

CEOC FINANCE CHIEF	
Location	
	Corporate Emergency Operations Centre.
Takes Direction From	
<input type="checkbox"/>	CEOC Director.
Confers With	
<input type="checkbox"/>	CEOC Chiefs.
<input type="checkbox"/>	CEOC Liaison Officer.
<input type="checkbox"/>	CEOC Risk Management Officer.
<input type="checkbox"/>	CEOC Information Officer.
All Levels	
<input type="checkbox"/>	Document all activities utilizing the ICS 214 – Activity Log.
<input type="checkbox"/>	Ensure that accounting standards for response efforts are established and communicated.
<input type="checkbox"/>	Approve necessary banking and funding arrangements.
<input type="checkbox"/>	Approve payment authorization limit for field response team personnel.
<input type="checkbox"/>	Attend CEOC planning meetings.
<input type="checkbox"/>	Track procurement costs.
<input type="checkbox"/>	Track compensation claims.
<input type="checkbox"/>	Compile employee and contractor time tracking.
<input type="checkbox"/>	Determine the level and detail of documentation required for insurance requirements.
<input type="checkbox"/>	Provide guidance on effective purchasing practices to achieve cost savings for products and services.
Deactivation	
<input type="checkbox"/>	Evaluate public and other third-party claims.
<input type="checkbox"/>	Compile loss estimates and summarize expected financial impact.
<input type="checkbox"/>	Approve compensation payments.
<input type="checkbox"/>	In conjunction with the insurance company, settle claim payment.
<input type="checkbox"/>	Gather all incident related documentation from the CEOC Finance Team and ensure all documentation is submitted to the Planning Section.
<input type="checkbox"/>	Participate in the post-incident debriefing held by the Incident Commander.
<input type="checkbox"/>	Participate in the Critical Incident Stress Debriefing as required.

CEOC FINANCE CHIEF

Forms	
<input type="checkbox"/>	ICS 214 – Activity Log
<input type="checkbox"/>	Evacuee Expense Claim Form

4.10 CEOC Administration/Scribe

The CEOC Administration/Scribe provides documentation and administrative assistance to the CEOC. This includes the recording of meeting minutes, information filing, and reproduction tasks. If required, a Scribe may be assigned to solely maintain a written record of the incident response.

CEOC ADMINISTRATION/SCRIBE	
Location	
<input type="checkbox"/>	Corporate Emergency Operations Centre.
Takes Direction From	
<input type="checkbox"/>	CEOC Director.
All Levels	
<input type="checkbox"/>	Document all activities utilizing the ICS 214 – Activity Log.
<input type="checkbox"/>	Maintain a chronological summary of the incident response activities.
<input type="checkbox"/>	Record names of personnel in each assigned response position and their location utilizing ICS 211 – Check-In List and ICS 207 – Incident Organization Chart.
<input type="checkbox"/>	Record control and containment measures.
<input type="checkbox"/>	Record environmental monitoring information.
<input type="checkbox"/>	Record injuries, deaths, and missing persons.
<input type="checkbox"/>	Record phone calls.
<input type="checkbox"/>	Record decisions.
<input type="checkbox"/>	Record actions.
<input type="checkbox"/>	Record status of the public protection actions.
<input type="checkbox"/>	Collect documentation from response team members.
<input type="checkbox"/>	Maintain a consistent system for organizing the data.
Deactivation	
<input type="checkbox"/>	Gather all incident related documentation from the CEOC Finance Team and ensure all documentation is submitted to the Planning Section.
<input type="checkbox"/>	Participate in the post-incident debriefing held by the Incident Commander.
<input type="checkbox"/>	Participate in the Critical Incident Stress Debriefing as required.

CEOC ADMINISTRATION/SCRIBE

Forms	
<input type="checkbox"/>	ICS 207 – Incident Organization Chart (may be completed by CEOC Planning Chief, if assigned)
<input type="checkbox"/>	ICS 211 – Check-In List
<input type="checkbox"/>	ICS 214 – Activity Log
<input type="checkbox"/>	ICS 234 – Work Analysis Matrix
<input type="checkbox"/>	Environmental Monitoring Record
<input type="checkbox"/>	Status Board

5.0 COMMAND CENTRES AND RESPONSE LOCATIONS

To coordinate response efforts, the Company and Government will establish various Command Centres to facilitate required actions. These centres represent the location of specific members of the response team and may be set up temporarily (in a vehicle for example) or long-term (field or head office) depending on the nature of the emergency and the availability of a facility. The following Command Centres would be established as required depending upon the nature and seriousness of the incident.

5.1 On-Site Command Post (OSCP)

The On-Site Command Post is at 'ground zero' and will be located as close to the actual incident site as possible given safety concerns. This location is where the On-Site Group Supervisor would manage actions to control and mitigate the situation and coordinate subsequent remedial activities.

The On-Site Command Post is the focal point for control and containment activities as well as communications to the Incident Command Post. The Incident Command Post and On-Site Command Post can be located at the same place.

5.2 Incident Command Post (ICP)

The Incident Command Post is the location from which the Incident Commander oversees all incident operations. Key field response activities, including public safety actions, are coordinated from this centre. It must have the appropriate equipment and resources, including good communication equipment, to manage the emergency. The ICP will be established near the site of the emergency but outside of the hazard area. Often the Incident Command Post is located in the closest company office, a nearby facility or building. It may be combined with the Regional Emergency Operations Centre.

5.3 Staging Area

The decision to establish a staging area will be made by the Site Operations Section Chief as directed by the Incident Commander. The staging area is a control point for regulating the flow of equipment and services.

The Staging Area is used for the initial drop off of heavy equipment and large numbers of personnel used in an emergency response. This will greatly aid the efficiency and preparedness of all equipment movement into the EPZ when required. Resources in the Staging Area need to be ready for deployment within five minutes from the incident site, if at all possible. When establishing the Staging Area, ensure that it has adequate entrance and exit routes and is on a paved surface, if possible.

5.4 Reception Centre

Reception Centres are established to provide a safe place for people within an established EPZ, including employees, contractors, and site visitors, to evacuate to during an emergency.

Reception Centre Activation Procedures:

Local Authorities may have predetermined reception centre locations identified within their Municipal Emergency plan. Early contact with the local authority will ensure a coordinated response between the municipality and Company.

Unless otherwise requested by a Local Authority, the company will select a reception centre that is a safe distance from the release source and that can accommodate company personnel, the public and any other evacuees.

Services provided include registration and inquiry, emergency food services, emergency clothing services, emergency lodging services, and personal services.

A company representative will be assigned to travel to the Reception Centre, along with the Local Authority's representative, if applicable, to meet and register evacuees, and coordinate activities.

Arrangements for accommodation, reimbursement of daily expenses and temporary care of evacuated property are managed through the centre.

5.5 Helibase

A Helibase is a location where aircraft are maintained and fuelled. If helicopter evacuation is or may be a requirement, the helicopter services may be placed on standby at a Level 1 Emergency.

5.6 Helispot

The Helispot is the temporary location where the helicopter can land to load or unload evacuees, equipment, and supplies. Rover/Evacuation personnel will be located at each Helispot to assist evacuees including non-essential employees, contractors, and site visitors.

5.7 Corporate Emergency Operations Centre (CEOC)

Significant emergencies impact a business in many ways including reputation loss, regulatory non-compliance, the incurring of legal liabilities, financial loss, etc. During a Hierarchy 2 emergency the CEOC Team will assemble and provide support to the affected location.

The CEOC is the principal site of response coordination to support the Incident Commander. This is the centre where head office support activities are coordinated, it includes Company representatives with adequate authority, technical, and media relations skills. It is the location where personnel formulate strategies and action plans to manage regional emergency response issues.

The CEOC is equipped with the tools, accessibility and space to accommodate the CEOC Team and support personnel.

5.7.1 Suggested Equipment and Supplies for the CEOC

Office Equipment and Supplies	
<input type="checkbox"/> Pens/Pencils	<input type="checkbox"/> Appropriate batteries for all equipment
<input type="checkbox"/> Felt-tip markers	<input type="checkbox"/> Appropriate printer cartridges
<input type="checkbox"/> Dry erase markers	<input type="checkbox"/> Envelopes of various size
<input type="checkbox"/> Coloured grease pencils	<input type="checkbox"/> Light bulbs
<input type="checkbox"/> Pencil sharpeners	<input type="checkbox"/> Paper for flip charts
<input type="checkbox"/> Staples/staplers	<input type="checkbox"/> String
<input type="checkbox"/> Staple removers	<input type="checkbox"/> Photocopy/printer paper
<input type="checkbox"/> Scissors	<input type="checkbox"/> Identification tags/name plates
<input type="checkbox"/> Scotch tape/tape dispenser	<input type="checkbox"/> CEOC forms
<input type="checkbox"/> Notepads	<input type="checkbox"/> Laminated Status Board
<input type="checkbox"/> Calculator(s)	<input type="checkbox"/> Laminated ICS 234 – Work Analysis Matrix
<input type="checkbox"/> Elastic bands	<input type="checkbox"/> Clocks
<input type="checkbox"/> File folders	<input type="checkbox"/> Waste baskets/recyclable containers
<input type="checkbox"/> In/Out boxes	<input type="checkbox"/> Stamps (“For Action”, “Completed”, “Approved”)
<input type="checkbox"/> Map tacks/thumb tacks	<input type="checkbox"/> Flashlights
Communications Equipment	
<input type="checkbox"/> Telephones	<input type="checkbox"/> Telephone Conference Unit (Polycom)
<input type="checkbox"/> Phone/computer cables	<input type="checkbox"/> Computers/laptops with networking capability
<input type="checkbox"/> Power boards	<input type="checkbox"/> LCD projector/screen
<input type="checkbox"/> Extension cords	<input type="checkbox"/> Overhead projector
<input type="checkbox"/> Television/DVD player	<input type="checkbox"/> AM/FM radios
<input type="checkbox"/> Digital cameras/video camera	<input type="checkbox"/> Fax machine
<input type="checkbox"/> Memory card(s)/disc(s)/tape(s) for cameras	<input type="checkbox"/> Photocopier
Furnishings	
<input type="checkbox"/> Workstation desks/tables	<input type="checkbox"/> Filing cabinet(s)
<input type="checkbox"/> Conference table(s)	<input type="checkbox"/> Whiteboard(s)
<input type="checkbox"/> Map stand	<input type="checkbox"/> Cork boards
<input type="checkbox"/> Chairs	<input type="checkbox"/> Flip chart stands
<input type="checkbox"/> Bookshelf/shelves	<input type="checkbox"/> Coat rack/hangers
Reference Materials	
<input type="checkbox"/> Updated CEOC floor plan	<input type="checkbox"/> Contingency plans
<input type="checkbox"/> Checklists (operational guidelines)	<input type="checkbox"/> Local, area, and regional maps
<input type="checkbox"/> Updated contact/supplier/media lists	<input type="checkbox"/> Aerial photos
<input type="checkbox"/> Current phone/email lists	<input type="checkbox"/> Resource inventories
<input type="checkbox"/> Emergency Response Plans (with extras)	<input type="checkbox"/> CANUTEC guide
<input type="checkbox"/> OHS Standards	<input type="checkbox"/> TDG Regulations
Store Supplies and Dispensary	
<input type="checkbox"/> Paper towels	<input type="checkbox"/> Facial tissue/Kleenex
<input type="checkbox"/> First aid kit	
Food Service Areas	
<input type="checkbox"/> Coffee/tea	<input type="checkbox"/> Pitchers
<input type="checkbox"/> Kettle/tea pot	<input type="checkbox"/> Glasses/paper cups
<input type="checkbox"/> Coffee maker filters/coffee pot	<input type="checkbox"/> Refrigerator/freezer
<input type="checkbox"/> Mugs	<input type="checkbox"/> Stove
<input type="checkbox"/> Food preparation/serving equipment	<input type="checkbox"/> Dishwashing supplies
<input type="checkbox"/> Eating utensils/dinner plates	<input type="checkbox"/> Storage cabinets
<input type="checkbox"/> Food supplies	<input type="checkbox"/> Garbage bags
<input type="checkbox"/> Water	

5.8 Government Command Posts

5.8.1 Regional Emergency Operations Centre (REOC)

If it is taking a considerable amount of time to bring an emergency under control or if the external support requirements are substantial, the appropriate government agency will establish a REOC in the area.

The REOC is a single operations centre that is established in a suitable location to manage the larger aspects of the emergency and it is managed jointly by government and industry staff. The Regulatory Authority encourages the combination of industry and municipal responses into a single REOC if possible.

This centre has two functions:

1. To provide a central location for addressing the demands and coordinating the services of various government agencies.
2. To provide a centre for public and media interaction.

If a REOC is established, the Company will dispatch a Liaison to the centre to represent the company's view on management, technical, and public affairs issues. The REOC may be combined with a Company command post in order to centralize personnel.

5.8.2 Municipal Emergency Operations Centre (MEOC)

The MEOC is activated by the Local Director of Disaster Services to support the local authority's emergency response. The MEOC can assess the capability of Municipal Government services and other available resources necessary to support the emergency response.

5.8.3 Government Emergency Operations Centre (GEOC)

If the incident affects more than one local authority, provincial/state involvement may necessitate the need for activation of a GEOC.

6.0 CRISIS COMMUNICATION PLAN

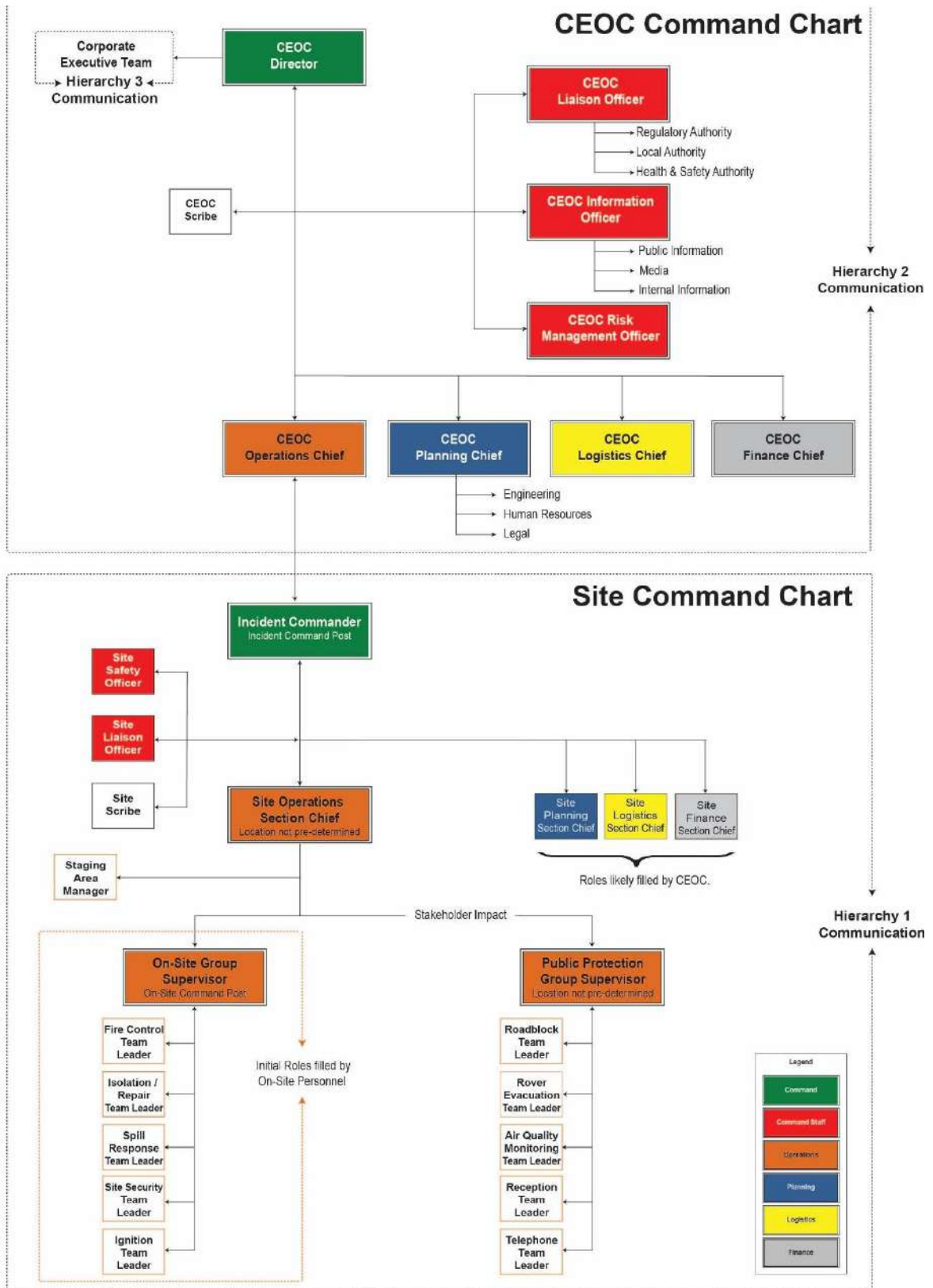

6.1 Purpose of the Crisis Communication Plan

A crisis communication plan provides policies and procedures for the coordination of communication within the organization and between the organization and any applicable outside agencies (e.g. the media, regulatory agencies, customers, suppliers, stakeholders, and the public) in the event of an emergency or controversial issue.

6.2 Crisis Communication Policy

The Company will conduct all aspects of response to a crisis with transparency, timeliness and honesty and will strive to implement effective communication channels between the Company and all stakeholders in the event of a critical incident.

All communication is designed from the following perspectives:

- Comply with all applicable laws and regulations making use of industry standards and best practices where appropriate.
- Accept accountability of the operation, of its assets, and the conduct of its employees, contractors, and consultants.
- Communicate openly with all stakeholders.

6.3 Crisis Communication Plan Objectives

The Communication Plan Objectives are as follows:

- To factually assess the situation and determine whether a communication response is warranted.
- To assemble personnel who will make recommendations on appropriate responses.
- To implement immediate action to:
 - Identify those parties who should be informed about the situation.
 - Communicate facts about the crisis.
 - Minimize rumours.
 - Restore order and/or confidence.

6.4 Crisis Communication Audiences

Important audiences for the Company during an emergency event includes employees, contractors, residents, businesses, visitors, stakeholder organizations, all levels of government, media, and the general public who are considered to be at risk. Priority in messaging will be given to those considered at greatest risk.

6.5 Internal Communication and Command Centres

Effective command, control, and coordination of the incident is dependent on situational awareness gained from fully functioning communication processes and systems. This not only applies between the responders and the On-site Command Post, but also across the entire response effort. The Incident Command Post and the Corporate Emergency Operations Centre function as communication hubs and it is important that the relationship and function of each centre is understood.

Internal communications are those between the incident site, company response team members, and other contract emergency resources.

Equipment includes telephones, two-way radios, computer networks, as well as company and response plan contact lists. Outside resources should be procured to assist with the equipment needs. Any site-specific radio and communication infrastructure existing within an area owned either by the Company or through mutual aid should be integrated into the response communication plan. Specific telephone lines may be identified for incoming and outgoing purposes and specific locations may be set up as communication centres with designated media personnel. Roadblock, monitoring, and rover crews also utilize the communication equipment to report conditions and actions, on an ongoing basis, to the Incident Commander or a designate.

An organized, efficient and effective collection of these resources and procedures are considered an incident communication system. It is this system that captures and relays information and orders so that effective decision-making and action can occur throughout the emergency management structure.

The different types of response centres in the emergency communication system are described below.

6.5.1 *Communication at On-site Command Post*

The On-site Command Post is the primary emergency response location. It is located a safe distance away from the incident but close enough to facilitate site emergency response operations and communication. If necessary, this could be at a Company Facility or Mutual Aid Operator's Field Office.

6.5.2 *Communication at Incident Command Post*

The Incident Command Post is typically located at a nearby facility or field office and provides oversight, support, and coordination of regional (vs. site) response activities. Emergency Response activities at the Incident Command Post include the management of impacts to employees, stakeholders and operations.

The Incident Command Post will need to collect relevant tactical information to make a strategic picture of what is happening. Communication of this information from the On-site Command Post/ Incident Command Post is critical as it enables the Incident Commander to communicate a strategic picture to the Corporate Emergency Operation Centres.

This accurate strategic picture will assist the CEOC to maintain strategic situational awareness of the event allowing senior decision makers to identify and respond appropriately to issues occurring at regional, national, and international levels.

6.5.3 *Communication at the Corporate Emergency Operations Centre (CEOC)*

During an emergency which requires a Hierarchy 2 communication level, the Corporate Emergency Operations Centre will assemble and provide support to the affected location. This may include the aspect of various support sections (e.g. Legal, Information Officer, Finance, etc.) responding to the Incident Command Post.

6.5.4 *Communication with the Executives: President and Board of Directors*

During an emergency which requires a Hierarchy 3 communication level, the President and Board of Directors should be notified because significant incidents impact business in many ways including, reputation loss, regulatory compliance, the incurring of legal liabilities, financial loss, etc.

Concurrent with notification to the CEOC of the incident, the CEOC Director will confirm that the Corporate Executive Team will be the primary conduit for Board notification.

The Corporate Executive Team will notify the Board of the incident and commit to providing updates as the incident evolves.

6.6 Crisis Communication Process

To be effective, emergency response requires timely and efficient communication. The appropriate Company personnel and government/regulatory agencies must be informed of the potential for a serious incident (or the occurrence of a significant event requiring emergency support and response). Notification of a potential incident can occur in several ways: through external stakeholders, through detection by field personnel or through Company reception/ 24-hour emergency number.

Regardless of whether all information is available at the time, the CEOC Information Officer should produce a media statement in a timely manner indicating that the situation is under investigation.

6.6.1 24-Hour Emergency Number

The Company must establish a 24-hour emergency number for stakeholders to report an operational emergency such as smoke, fire, odours, or spills. This number appears on all facility, well, and pipeline crossing signs. The Company must ensure that incoming calls to the 24-hour emergency number initiate immediate action.

The 24-hour emergency number may be managed by a Call Centre which provides a 24-hour a day, 7 days a week live answering service to notify Company personnel based on a pre-defined call-down list.

During an emergency, the CEOC Information Officer must contact the Emergency 24-hour number attendant to ensure all media enquiries are directed appropriately.

6.6.2 Public Inquiry

Calls to the Company main switchboard are first directed to the CEOC where support staff will screen and collect information from all inquiries. CEOC support staff will then pass all incoming information requests or issues to the CEOC Information Officer. The CEOC Information Officer, in conjunction with the CEOC Director, will evaluate all incoming requests for action and response and either handle the requests directly or forward the requests onto the Incident Commander or the Corporate Executive Team to handle.

The appropriate notifications must start immediately when declaring an emergency incident. See Communication Flow diagram for notification and reporting flow process.

6.6.3 Command Centre Communication Flow Diagram

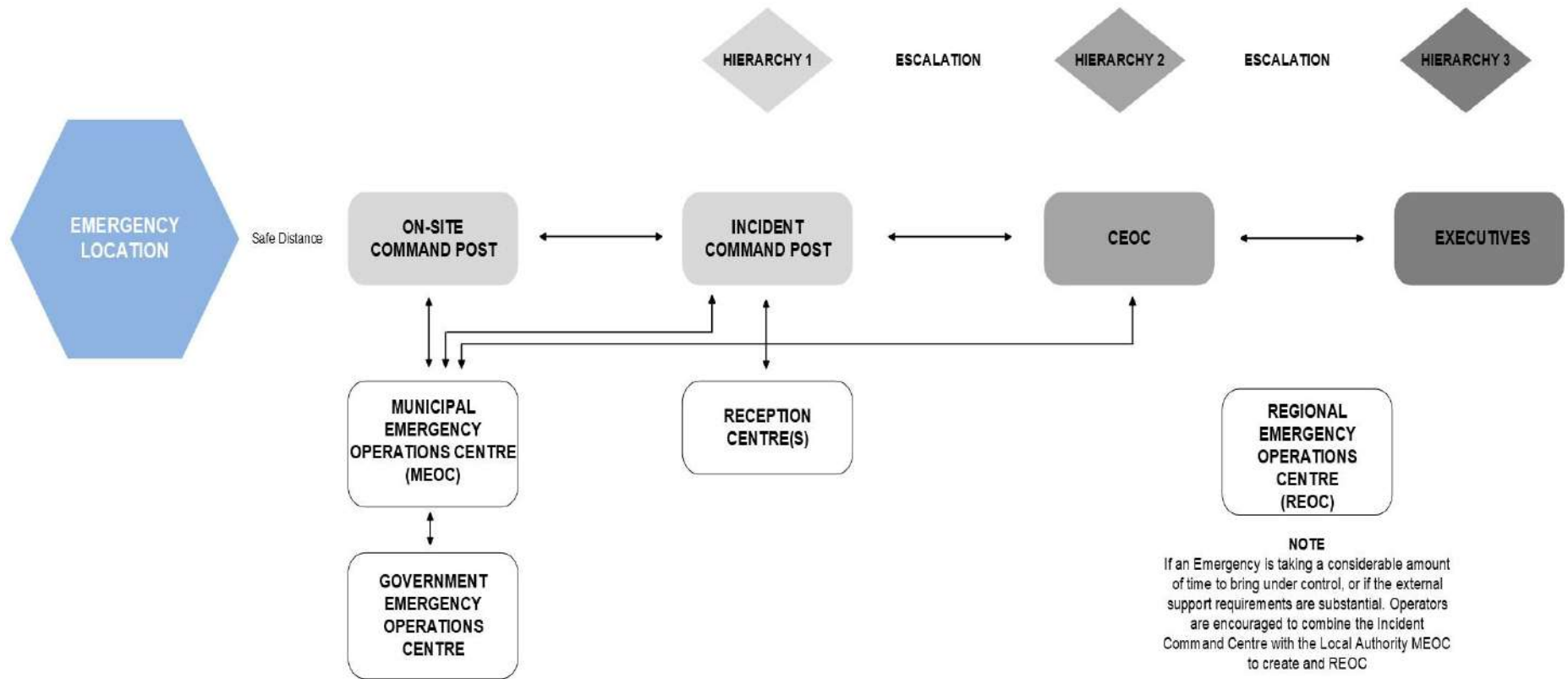

6.7 External Communication

6.7.1 Communication with Government/Regulatory

A key component of the plan is to establish and maintain effective two-way communication with government departments and regulatory agencies that have legislated responsibilities for emergency management within their jurisdiction.

6.7.2 Communication with the Public

Public communication can be done in person or by phone. The Company must provide the public with timely emergency information that addresses what actions, if any, are to be taken by the public (for example - shelter in place or evacuate). For extended emergency situations, scheduled information sessions should be conducted to keep the public and affected community updated on the incident (including environmental, health, or safety information).

The following Information must be disseminated to the public at the onset of and during an incident:

To those evacuated or sheltered - at onset	To those evacuated or sheltered - during	To the general public - during
<ul style="list-style-type: none"> • Type and status of the incident. • Location and proximity of the incident to people in the vicinity. • Public protection measures to follow, evacuation instructions, and any other emergency response measures to consider. • Actions being taken to respond to the situation, including anticipated time period. • Contacts for additional information. 	<ul style="list-style-type: none"> • Description of the products involved and their short-term and long-term effects. • Effects the incident may have on people in the vicinity. • Areas impacted by the incident. • Actions the affected public should take if they experience adverse effects. 	<ul style="list-style-type: none"> • Type and status of the incident. • Location of the incident. • Areas impacted by the incident. • Description of the products involved. • Contacts for additional information. • Actions being taken to respond to the situation, including anticipated time period.

6.8 Media Communication

In times of crisis, the public forms their opinions from various media sources. It is critical the company uses all available platforms to relay information to the public.

6.8.1 Media Crisis Communication Policy

Media releases should be coordinated with the applicable Regulatory Authority prior to release to ensure consistency and accuracy of information. The CEOC Director will delegate the CEOC Information Officer role to interact with the Regulatory Authority and other applicable government agencies.

It is expected that the designated CEOC Information Officer will interact with the media in a timely, open and honest manner.

When dealing with members of the press, Company representatives must:

- Demonstrate professionalism at all times.
- Be available for comment and response.
- Be timely and respect the increasingly fast pace of the news cycle.
- Be completely transparent.
- Provide only truthful and accurate information being mindful of the Company's continuous disclosure obligations and restrictions.
- Provide available point of contact for follow-up inquiries.
- Never comment on issues outside of your area of expertise.

Generally, other Company personnel are not permitted to make any verbal or written public statements regarding Company operational matters or events (e.g. accidents, spills, injuries) unless approved by the CEOC Information Officer.

Company goals are to:

- Limit public statements to only those that are deemed necessary.
- Make public statements solely from the Company's Head office.
- Present a unified and accurate corporate image to the community.
- Provide correct information to the public.
- To be in compliance with applicable laws, rules and regulations.

If approached by the media for an interview:

- Politely check and record credentials of media, news photographers, and public officials.
- Remember you are always "on-the-record" with the media.
- Assure the media that a Company representative will address their questions at a later time.
- All media inquiries at the emergency site must be forwarded to the CEOC Information Officer who is authorized to supply the media with a brief initial statement.
- Use the following statement as a guideline, never lie or say "no-comment".

Hello, my name is _____ (state your name).

"We are currently dealing with the situation at hand to ensure the safety of persons, property and the environment. The matter is being investigated. A statement will be released by the Company once the facts have been determined. If you would like to leave your contact information with me, I will promptly pass it on to someone who will contact you and provide you with information as it becomes available."

Name of Media Individual: _____

Media Organization: _____

Telephone Number: _____

6.8.2 Media Access to Emergency Site

Company safety procedures apply to everyone on-site. Therefore, to ensure the safety the media will not be allowed on-site unless otherwise agreed to by Senior Management. No objection should be made of the media filming or photographing the event provided they do so in a safe place, off the property.

The following information provides some additional guidelines when dealing with the media and public reactions.

6.8.3 Preliminary Holding Statement

A preliminary holding statement is a brief description of a critical situation. The statement is intended to be the first information that contains the key messages from the Company to the public, prior to any media release. It includes a brief description of the situation, including who was involved, what occurred and any other critical information. It is not meant to replace a media release or a press conference. The preliminary holding statement will be regularly updated by the CEOC Information Officer with the most current key points or messages from the company.

The preliminary holding statement should be provided to all telephone operators in the case of a crisis. The statement should be faxed or emailed to the Incident Commander and On-Site Group Supervisor as soon as approved so that the field location can communicate the same messages as Head Office. By having one consistent statement for all callers, the amount of conjecture, personal opinion and speculation is removed from the media contact.

Where a Preliminary Holding Statement is required by the media, the Statement shall contain:

Nature of Emergency:	General description of what happened. Do not give an opinion of the cause. Do not speculate. Use non-technical language.
Where, When:	Location of the site from the nearest major centre and the time the incident began.
Injuries/Fatalities/ Damages:	No opinions shall be given as to the extent of damage or injuries. State the number of people receiving treatment. No names are to be released until after permission has been granted by the next-of-kin.
Status:	Indicate the nature of the situation: what is being done and by whom.
When to Expect More Information:	The CEOC Information Officer, or alternate, will issue further information to the media. Ongoing media attention focused at the emergency site shall be referred to the CEOC Information Officer.

Sample Preliminary Holding Statement

Name of Media Representative: _____ Organization they work for: _____ Date: _____ Time (0-2400 hrs): _____
At approximately _____ (Time, am/pm) today, NorthRiver Midstream Inc. experienced a _____ (Fire/Explosion/Gas Release) at its _____ facility located approximately _____ kilometres (east/west/north/south) of _____ (Nearest Town/City).
<p style="text-align: center;">There are no injuries associated with this incident.</p> <p style="text-align: center;">or</p> <p style="text-align: center;">There are injuries associated with this incident. However, the numbers, names, and conditions of those injured have not yet been confirmed for release.</p>
<p style="text-align: center;">The cause of this incident is not yet known, and no estimate of damage is available. However, NorthRiver Midstream Inc. is directing emergency procedures at this time and steps are being taken by NorthRiver Midstream Inc. to control this incident.</p>
<p style="text-align: center;">For additional information about this incident, please call: _____.</p> <p style="text-align: center;">NorthRiver Midstream Inc. at _____.</p>

6.8.4 General Guidelines

- Be proactive in advising media of the situation to ensure consistent and appropriate communication to the public.
- Establish an agreed upon schedule for updating the media on a timely basis.
- Coordinate media communication with the Government Emergency Operation Centres if established.
- Return media calls promptly and courteously.
- Restrict comments to indisputable facts and brief descriptions of what is being done.
- Keep messages consistent.
- Record names and numbers for media contacts (so you can provide subsequent contact and updates).

The questions that should be answered are:

- What, where and when did it happen?
- Who was involved? (not providing any names)
- Why did it happen? Do not respond until you have facts – otherwise we are investigating the cause.
- What is the status of the situation?
- When will more information be expected?
- Which Government agencies were notified/are on the scene?
- Plus, any other relevant facts that will dispel rumour, speculation and fear.

DO	DO NOT
<ul style="list-style-type: none"> • Ensure individuals present for any media communication are authorized to be there. • Provide factual information quickly. A reporter will be on the next news broadcast regardless. It is in the Company's best interest that he/she has the facts and not just speculation and comments from others. • Have one person locally and one at the head office as designated spokespersons (all others will defer questions to them). • Keep your commitments. If you say you will check something, ensure you do. • If there is an important development, provide an information update immediately. • Show yourself as caring and concerned. • Reinforce that the Company has active safety, prevention, and response programs. • As soon as the Company can confirm, provide: <ul style="list-style-type: none"> ○ Estimate of when production or flow can be resumed. ○ Estimate of clean-up details (e.g. cost, time frame). ○ After notification of families, names of those injured. • Keep your answers brief. • Maintain strong eye contact with those asking questions. Wandering or averted eyes will make you seem dishonest. • Immediately provide the CEOC Information Officer with details of what you have said. • Keep a record of all media representatives' organizations and when you talk with them. • Politely correct reporters who have carried inaccurate information. 	<ul style="list-style-type: none"> • Never use the term "no comment." Those two words arouse suspicion. If you don't have the answer, say for example "I don't have that information now, but it is currently being investigated". • Do not speculate or guess. • Do not place blame on anyone – or accept any blame. Do not prejudge the situation by agreeing with any statement (e.g. you heard the driver was speeding). • Do not accuse anyone of negligence. • Do not discuss anything "off the record". • Do not discuss liability. • Do not get flustered by hostile questions: control any anger you may want to return. • Do not play favourites with reporters. Be consistent with the information you provide. • Do not ask to see or hear a reporter's story to check it before it goes. Do, however, make yourself available to confirm facts. • Do not answer hypothetical questions. Comment that the question is hypothetical and that every effort is being made to contain the situation. • Do not fall victim to the either/or question. Repeat your facts. • Do not repeat the reporter's negative or colourful words (e.g. deadly) even to deny them and do not accept or make comparison to other publicized situations. <p style="text-align: center;">Do not allow yourself to be positioned in front of a blowout for an interview or photograph but do try to find an interesting backdrop that you control.</p>

Public reaction to a crisis moves through four stages:

1. Curiosity This is the need (or want) to know stage.
2. Concern People want to know how it affects them, their community or region.
3. Anxiety If the Company does not seem to be informing a concerned public, anxiety sets in. People worry about their health and the environment.
4. Anger/Fear Emotions focus on the perceived threat to people's self-interest. Anger is directed in many directions, especially towards the Company and Government.

6.8.5 Media Release

A media release is a communication directed at members of the news media for the purpose of announcing something ostensibly newsworthy. Typically, they are faxed or e-mailed to assignment editors and journalists at newspapers, magazines, radio stations, television stations or television networks.

The media release starts with the most important information first (who, what, where, when, why). This is followed by additional information that may be important with supporting details. It ends with contact information. The objective of each media release is to build or maintain the Company's reputation and public support. The release should emphasize company values, convey empathy to show the public that the Company is concerned and is taking responsibility for the situation. Include only facts that can be confirmed and emphasize resolve of the company to get answers or rectify the problem.

The Media Release contains three core messages that form the basis of all public incident communications.

The Company's primary concern is to ensure the safety of all those affected by the incident, to work closely and cooperatively with all agencies involved and to address any environmental impacts.	A core message of empathy
The Company is putting its full effort into bringing the impact of the incident under control. As more information becomes available it will keep all stakeholders informed.	A core message of commitment and candor
Incident prevention comprises an integral part of the Company's job in all its facilities. However, specific details of how the incident occurred will be subject to a full investigation and it is not appropriate for the Company's to either comment or speculate on this at this time.	A core message of competence

6.8.6 *Crisis Media Interview*

Crisis interviews are intended to communicate that the Company:

- Has control over the situation.
- Is familiar with the crisis situation and has the knowledge to handle and resolve problem.
- Takes accountability for the situation and attempts to instill trust with the public in handling the crisis.

During crisis media interviews, the messages should be simple, without jargon and conducted in a slow and clear manner with action points repeated. An interviewee should listen with empathy and invoke conviction and compassion through tone of voice.

Before conducting an interview always review, revise, and rehearse. Ensure information is confirmed and factual, that key messages are well prepared, that the interviewee is comfortable in the chosen location for the interview, and that all the background information supports key points.

When asked a question by a media interviewer, the interviewee should take time to assess whether he or she has the authority to answer the question or the expertise (adequate subject matter knowledge) to answer question. If so, then frame your response with these 3 key points in mind:

- What is the answer – avoid extended preamble and get to the point succinctly.
- How did you derive this answer – use 2-3 supporting points to substantiate your answer.
- Opportunity – select the best key message for the audience to build trust and confidence for company's actions.

Remember the keys to effective crisis media relations are:

- Accuracy of information.
- Speed of release of information.
- Empathy and openness builds trust with stakeholders.

6.8.7 News Conference Guidelines

When you notify the media of news conferences be sure to define what kind of event you are having. News conferences are held to announce something for the first time.

- Do not call unnecessary news conferences, if it's not worth their time, the media will only be angered. If holding a news conference, try to tell media in advance some details that you will be announcing.
- Gauge the size of your crowd carefully when reserving a room; it is better to have too much than too little space. Make sure microphones, chairs, lighting, and water are in place at least 30 minutes prior to the event.
- Decide format in advance – who will introduce speakers, who decides when questions/answer period ends, and other details.
- Decide in advance whether handouts are needed. If speaker is giving a talk for which there is a text, you may want to wait and hand out material after the talk, so media will stay and listen. However, it's advisable to tell the media you will provide a text of the speech, so they are not irritated by having to take unnecessary notes.
- Check to see what else is happening in your organization or the community before scheduling a press conference.
- Consider whether you need to let other organizations and agencies know you are having a news conference. You may wish to invite others to attend or participate in your event.
- Decide who will maintain control at the news conference, who will decide where cameras are set up, and who sits where.
- Try to plan the length of the news conference but be flexible.
- Consider the time of the news conference. If you want to make the noon, 6 PM or 11 PM news, you need to allow time for crews to travel and edit tape.
- If you are going to set restrictions on an event such as limited photo access, try to put the restrictions in writing and communicate to the media at least 24-hours in advance.

6.8.8 Reporting

Regular status updates or status reports provided during the emergency response will be the responsibility of the CEOC Information Officer in consultation with the CEOC Director. Reports should be provided to the agencies at defined intervals or as frequently as updates are required. Reporting intervals may be adjusted as the situation develops. Reporting will continue until the emergency has been declared over and the response effort has stood down.

Specifically, the Communication Plan establishes a guideline for the following core communication expectations:

Communication	Suggested Timeline
Notifications to internal staff and regulators	As per CEOC Director
Initial written public holding statement	Within 1 hour of CEOC team activation for a Level 2 or 3 crisis
Media release	Within 2 hours of CEOC team action for a Level 3 crisis
Media appearance (if required) and spokesperson preparation	Within 3 hours of communication team activation for a Level 3 crisis
News conference (if required)	Prior to 4 PM if possible
Formal updates – media release, continuous disclosure obligations	Every 4-6 hours or as situation warrants

6.9 Social Media

The use of social media, (Facebook, Instagram, “X”, Reddit, etc.) to communicate with the public can be a very efficient and effective form of communication during an incident. With the release of one small statement the Company can potentially notify a large segment of the population.

Social media provides a form of two-way communication with the public during an emergency situation. Social media provides the ability to directly see how a situation is affecting people and gives the opportunity to respond to them, keeping them informed, preventing panic, and keeping rumors at bay. By following keywords and hashtags, the Company is able to easily monitor what the community is saying about the incident and respond accordingly.

It should be noted that news organizations are increasingly monitoring social media as a way to find news stories; in some cases, finding out about events before a company.

During an emergency in the CEOC Information Officer should appoint an assistant to monitor social media. The designated person can employ a web program such as “HootSuite” to monitor several social media feeds at once.

6.10 Mutual Aid Agreements

A wide range of emergencies may occur that have an impact on neighbouring stakeholders. In this event, multiple parties may want to provide assistance during the emergency.

It must be agreed upon prior to any type of third party response that NorthRiver will remain the primary emergency responder, and that any assistance provided by third parties must be under the supervision of a NorthRiver representative. Furthermore, the party providing mutual aid must comply with all applicable NorthRiver policies and applicable government regulations.

If another Area Operator provides assistance, the principal behind this assistance should remain as follows:

- Companies or individuals providing assistance are to provide the support outside the lease boundary. The focus will be to provide the manpower and support required for roadblock crews, rovers, resident contact, and evacuation co-ordination as required by NorthRiver requesting the assistance.
- Third party responders will report to the Incident Commander or other coordinating position in the area.
- Individuals providing assistance retain the right to withdraw the assistance should their personal safety be jeopardized.

6.11 Emergency Answering Procedures

When answering telephone calls listen to the person on the other end of the line carefully. You need to determine whether this is an emergency situation or not. Try to get the following information, repeat it back for clarification.

- Record the time of day.
- Make sure you ask and log the following information:
 - The person’s name.
 - The person’s phone number.
 - The exact location of the person calling.
 - Directions to the caller’s home/incident site.
 - The exact location of the potential emergency.
 - The extent of injuries or damage.
 - Wind direction.
 - Nature of emergency.
- Please tell the caller to call _____ (collect) if their situation changes or gets worse.
- Call the Company representative for that area and relay all the information. Fax, or scan and email, a copy of the recorded information to the responder.

Please remember how important this information is as you will have to relay it to a Company representative.

If the person calling is agitated, try to keep them on the line long enough to get this information. Let them know a Company representative will be dispatched to check out the incident and will contact them with further information.

6.11.1 General Evacuation Script

<p>Ensure you are speaking with the correct person. Record answers to your questions on a separate sheet of paper. Speak slowly, calmly and clearly.</p>
<p>Mr./Mrs. _____, this is _____ of NorthRiver Midstream Inc. calling.</p> <p>I am phoning you because we are experiencing some _____ problems at the nearby _____ property.</p> <p>This situation does not pose any immediate threat, but we want you to be aware of it in case the situation gets worse.</p> <p>If it does, we will call back and ask you to go to the _____ reception centre. Would you need any help in getting to the _____?</p> <p>I will be calling back, in any event, to give you an update.</p> <p>If you have any questions, please phone me, collect, at _____.</p> <p>If at all possible, please avoid the use of your telephone, so we can call you again quickly with further information.</p> <p>Thank you.</p>

Immediately report, to the Telephone Team Leader, the names of all residents not contacted.

6.11.2 Shelter in Place Script

Telephone message for Residences/Businesses inside the EPZ where it is initially deemed unsafe to evacuate.

<p>Ensure you are speaking with the correct person. Record answers to your questions on a separate sheet of paper. Speak slowly, calmly and clearly.</p>
<p>Mr./Ms. _____, this is _____ from NorthRiver Midstream Inc. calling. We are experiencing a gas leak, which has created a vapour cloud (plume) that may be toxic or cause a serious fire and explosion near your home. NorthRiver Midstream Inc. is currently responding to the emergency. For your safety it is essential that you and your family/associates, remain sheltered indoors, preferably at the upper levels in your house until we can evacuate you safely or until the situation is under control and this serious hazard no longer exists.</p> <p>Please take the following actions immediately:</p> <ol style="list-style-type: none">1. Gather everyone in the house and close all windows and doors.2. Extinguish all potential sources of ignition, including open flames.3. Do not smoke.4. Turn off the electrical power at your switch box.5. If possible, plug any fresh air intakes or vents to your home, or furnace.6. Move to the upper levels of your house.7. Use a portable radio and stay tuned to a local station for public information. <p>Do not leave your house or attempt to start any vehicle until NorthRiver Midstream Inc. advises you that the area is safe.</p> <p>Do you understand what I have just told you?</p> <p>A Company representative or the local police will come to your house as soon as the fire and explosion hazard no longer exists.</p> <p>If at all possible, please avoid the use of your telephone, so we can call you again quickly with further information.</p> <p>If you have urgent questions, please call NorthRiver Midstream Inc. at _____*</p> <p>The Telephone Team Leader will designate the phone number at the time of the incident.</p> <p>Thank You</p>

6.11.3 Urgent Evacuation Script

<p>Ensure you are speaking with the correct person. Record answers to your questions on a separate sheet of paper. Speak slowly, calmly and clearly.</p>
<p>Mr./Ms. _____, this is _____ of NorthRiver Midstream Inc. calling. I want to tell you about a/the serious _____ we are experiencing at our _____ location.</p> <p>The wind is carrying the escaping gas to the north/south/east/west.</p> <p style="text-align: center;">YOU ARE IN NO IMMEDIATE DANGER.</p> <p>However, as a safety precaution, we want you to leave your premises and go right away to the reception centre located at _____.</p> <p>How many people are currently at your home?</p> <p>Are there any medical considerations or other special concerns that could affect your safe evacuation?</p> <p>Do you have transportation? If not, please stay indoors and close all windows and doors. We will send one of our drivers and vehicles to get you right away.</p> <p>If you have transportation, please take the north/south/east/west route, which will take you safely out of the endangered area. You can then travel by _____ to get to the reception centre.</p> <div style="border: 1px dashed black; padding: 5px;"><p>Read the following paragraph only during school hours:</p><p>We have contacted the schools and have arranged to hold students at the school. You may pick them up there or would you like to have us take them to the reception centre? What are your children's names and which school are they at?</p></div> <p>It is very important for us to know where you are and where you can be contacted both during and after the evacuation. Please report to the reception centre to confirm your accommodations and other support you may need.</p> <p>Any concerns you have regarding livestock, pets, or property will be addressed by our representatives at the reception centre.</p> <p>Please try not to use your telephone as it may tie up the lines and prevent us from calling other residents.</p> <p>Immediately report, to the Telephone Team Leader, the names of all residents not contacted.</p>

6.11.4 Notification Script

Ensure you are speaking with the correct person.
Speak slowly, calmly and clearly.

Mr./Ms. _____, this is _____ of NorthRiver Midstream Inc. calling. I am calling with an important message.

NorthRiver Midstream Inc. has an emergency near your location, which does not affect your safety; REPEAT, does not affect your safety. You are in no danger at this time; NorthRiver Midstream Inc. is notifying you for informational purposes only.

Repeat: You are in no danger at this time; we are notifying you for informational purposes only.

If you would like to voluntarily evacuate, please go to the Reception Centre located at the _____.

For further information, please contact NorthRiver Midstream Inc.'s 24-hour emergency number at 1-844-667-8477.

7.0 RESPONSE ACTION PLANS AND PROCEDURES

Emergency Response Action Guidelines for Site and Corporate Command

7.1 Purpose

The following examples of emergency response actions have been developed to provide a guide for response personnel. They should be reviewed and (if applicable) implemented as part of a specific emergency response.

The Site Command and Corporate Emergency Operations Command staff may follow these guidelines to protect worker and public safety.

7.2 Incident Site Worker Protection

To ensure that workers take the appropriate actions in the event of an emergency they should be properly trained and familiar with the Company emergency response strategy. This includes the following:

Actions:

- Ensure familiarity with egress routes and the muster point.
- Know where the safety equipment is located (fire extinguishers, first aid kits, gas monitoring equipment, and personal protective equipment).
- Understand how to initiate a site evacuation by sounding an alarm.
- If required, assist with a head count at the muster point and identify any missing personnel.
- Provide medical aid to an injured worker.
- Ensure that there is an accounting system in place for on-site personnel.

7.3 Personal Protective Equipment (PPE)

All responders should be properly equipped with PPE in their role as first responders at a Company site. In prolonged emergency response situations, a critical role of the Site Logistics Section Chief is to ensure that adequate quantities of all types of equipment and clothing are available for response personnel including essential spare parts (e.g. additional air bottles, bunker gear etc.). Local suppliers of safety equipment should be pre-identified.

Respiratory Protection:

- **Supplied-Air Breathing Apparatus (SABA):** Supplies air from air carts rather than breathing ambient air.
- **Self-Contained Breathing Apparatus (SCBA):** Supplies air from tanks carried on the responder's back with a full face-piece.
- **Air-Purifying Respirators:** Used when vapour concentration levels are confirmed to be safely below the level for the chemical involved.

Protective Clothing:

- **Penetration:** Liquid or vapour passes through seams or small openings in the clothing.
- **Degradation:** Breakdown of the clothing material caused by the action of the chemical.
- **Permeation:** Molecules of liquid or gas move through clothing material.

7.3.1 Protection Levels

There are four general levels of responder protection, which are recognized in both the U.S. and Canada. These are outlined in the table below.

- For solvents and Styrene, initial responders will probably require Level B protection until vapour concentration levels have been confirmed. Follow-up responders should have Level C protection.
- For certain specialty chemicals like Phenol, Level A protection may be required depending on the nature and location of the incident.

Levels of Responder Protection for Spill Response

Protection Level	Situation	Protective Equipment
A	Entry into unknown or high levels of skin-permeating chemicals.	SCBA and totally-encapsulated or gas-tight suit.
B	High concentrations – no skin-permeating chemicals present.	SCBA and chemical resistant clothing and gloves, boots.
C	Known levels of non-permeating chemicals.	Air-purifying respirator, liquid-repellent clothing, gloves, boots, safety goggles/glasses, and hard hat.
D	Chemicals well below danger levels.	Coveralls, gloves, boots, safety goggles or glasses, hard hat.

7.4 Hazard Monitoring Procedures

7.4.1 Stationary and Mobile Air Quality Monitoring Units

Activation and Use of Hazard Monitoring Equipment:

Intended Use:

- **Stationary Units:** These are typically installed at fixed locations to continuously monitor air quality in specific areas. They are used to detect and measure pollutants such as volatile organic compounds (VOCs), particulate matter (PM), and other hazardous substances (H₂S).
- **Mobile Units:** These units can be transported to different locations as needed. They are useful for temporary monitoring in areas where stationary units are not installed or during specific events or incidents.

Activation Procedures:

Ensure that stationary air quality monitoring units are activated immediately upon detection of a hazardous substance release. Mobile units should be deployed to strategic locations within the EPZ to provide real-time data.

Stationary Units:

- Ensure the unit is properly installed and calibrated according to the manufacturer's instructions.
- Power on the unit and verify that all sensors are functioning correctly.
- Set the monitoring parameters (e.g., types of pollutants, threshold levels) based on the specific requirements of the area being monitored.
- Begin continuous monitoring and regularly check the data output for any signs of hazardous substances.

Mobile Units:

- Transport the unit to the desired location and set it up according to the manufacturer's guidelines.
- Power on the unit and perform a calibration check.
- Configure the monitoring parameters as needed.
- Start the monitoring process and periodically review the data for any indications of hazardous substances.

Air Quality Monitoring equipment will be used to:

- Track the plume.
- Determine if ignition criteria are met.
- Determine whether evacuation and/or sheltering criteria have been met, particularly beyond the EPZ.
- Assist in determining when the emergency can be downgraded.
- Determine roadblock locations.
- Determine concentrations in areas being evacuated to ensure that evacuation is safe.

Downwind Mobile Air Quality Monitoring Requirements		
Level 1 Emergency	Level 2 Emergency	Level 3 Emergency
Deploy unit(s) to area of release and commence mobile air quality monitoring.	Continue mobile air quality monitoring. Request additional air quality monitoring unit(s) if required.	Continue mobile air quality monitoring. Request additional air quality monitoring unit(s) if required.

Determining the Response Zone Using Monitoring Equipment

Response personnel required to determine the extent of the response zones with handheld monitoring equipment must take the following precautions to protect their safety:

- Use the buddy system.
- Equip each responder with reliable H₂S detection and respiratory protective equipment.
- Establish and maintain communication with the Incident Command Post.
- If walking a pipeline right-of-way, walk a safe distance apart staying within visual and audible contact. As the lead responder monitors for H₂S, the backup responder will maintain communication and be prepared to rescue.

Detection

- Portable 3 or 4-head gas monitor.
- Mobile Air Monitor Units.

Record all Information

- Concentrations in ppm.
- Location and time of readings.
- Wind speed and direction.

Communication and Documentation

- Report all information to Public Protection Group Supervisor or Site Operations Section Chief.
- Notify Roadblock Personnel and Response Teams of changes.

7.4.2 Personal Handheld Monitors

Intended Use:

- These monitors are designed for individual use to detect and measure exposure to hazardous substances in real-time. They are commonly used by workers in environments where there is a risk of exposure to toxic gases, vapors, or particulate matter.

Activation Procedures:

- Ensure the monitor is fully charged and calibrated.
- Power on the device and check that all sensors are operational.
- Set the desired monitoring parameters (e.g., specific gases or particulates to be detected).
- Wear the monitor as instructed, ensuring it is positioned correctly to provide accurate readings.
- Continuously monitor the readings and respond to any alarms indicating the presence of hazardous substances.

Continuous Monitoring:

- Dispersion Monitoring: Utilize software and modeling tools to continuously monitor the dispersion of hazardous substances. Data from monitoring units should be integrated into the incident command system for real-time analysis and decision-making.

Data Analysis and Response:

- Regularly review the data output from the monitoring equipment to identify any trends or changes in the levels of hazardous substances.
- Use real-time data to make informed decisions about evacuation, containment, and mitigation measures.
- Communicate findings to relevant personnel and authorities to ensure a coordinated response.

Post-Incident Review:

- After the incident, analyze the collected data to evaluate the effectiveness of the monitoring procedures and response actions.
- Update hazard monitoring protocols based on lessons learned to improve future incident management.

Specification of Hazard Monitoring Devices:

- **Type of Hazard:** Select appropriate monitoring devices based on the specific type of hazard (e.g., gas detectors for H₂S, VOC monitors for hydrocarbons).
- **Entry and Egress Points:** Assess and deploy monitoring devices, if required, to identified access and egress points to ensure comprehensive coverage.
- **Population Density and Distance:** Based on the type of incident consider the population density and proximity to urban centers or rural subdivisions when determining the number and placement of monitoring devices.
- **Local Weather and Topography:** Account for local weather conditions and topographical features that may affect the dispersion of hazardous substances.

7.5 Isolation Procedures

Establishing Manned Roadblocks

Site Assessment:

- Conduct a thorough assessment of the site to identify strategic locations for Roadblocks.
- Determine the number of Roadblocks needed based on the size and layout of the area, as well as the expected traffic flow.

Design and Setup:

- Design the Roadblocks to include necessary infrastructure such as barriers, gates, and signage, as required.
- Ensure the Roadblocks are equipped with communication devices, lighting, and surveillance cameras, as required.
- Install stationary air quality monitoring units at each Roadblocks to continuously monitor for hazardous substances, if required.

Staffing:

- Assign trained personnel to each Roadblocks to manage entry and egress, if required.
- Ensure staff are equipped with personal handheld monitors to detect hazardous substances in real-time.
- Provide staff with protective gear and emergency response equipment.

Managing Manned Access Control Points/ Roadblocks

Access Control Procedures:

- Implement strict access control procedures to verify the identity and authorization of individuals entering and exiting the area.
- Maintain a log of all entries and exits for record-keeping and incident tracking.

Hazard Monitoring:

- Continuously monitor air quality at Roadblocks using stationary units and/or personal handheld monitors, as required.
- Set up mobile air quality monitoring units to provide additional coverage as needed.
- Regularly review monitoring data to detect any signs of hazardous substances.

Incident Response:

- Establish clear protocols for responding to incidents involving hazardous substances.
- Train staff on emergency procedures, including evacuation, containment, and communication.
- Ensure staff can quickly activate emergency response equipment and notify relevant authorities.

Communication and Coordination:

- Maintain open lines of communication between Roadblocks and central command.
- Use communication devices to relay real-time information about air quality and security status.
- Coordinate with emergency response teams to ensure a swift and effective response to incidents.

Periodic Review and Training:

- Conduct regular reviews of Roadblocks procedures and performance.
- Update protocols based on lessons learned from incidents and drills.
- Provide ongoing training to staff to ensure they are prepared to manage Roadblocks effectively.

These procedures ensure that manned Roadblocks are established and managed effectively to maintain security and monitor for hazardous substances, thereby protecting personnel and the environment.

Special Procedures for Major Highways and Railways:

- **Coordination with Authorities:** Coordinate with local transportation authorities to manage traffic and ensure the safety of major highways and railways passing through the EPZ.
- **Traffic Control Measures:** Implement traffic control measures such as roadblocks, detours, and temporary closures to prevent exposure to hazards.

7.5.1 Suggested Roadblock Equipment

- H₂S, LEL, CO, O₂ detection equipment (handheld instruments).
- High-visibility reflective vests.
- Communication equipment.
- Poisonous gas signs.
- Road barriers.
- ERP maps.
- Reflective triangles or cones.
- Flashlights (with batteries).
- Appropriate forms, such as air monitoring record and roadblock log of people leaving and entering the PAZ.
- Handheld stop signs.
- Personal protective equipment.
- Flares and/or flashing lights.
- First aid equipment.
- SCBA.
- Pens.
- Portable rotating emergency lights.
- Waterproof bag.
- Caution tape.
- Rain suit.

The permit holder must ensure that company equipment is operational meets industry standards.

7.5.2 *Setting up a Roadblock*

- Park vehicle on an angle across the lane, activating four-way flashers and roof-mounted rotating beacon.
- Put on a reflective vest.
- Take a reading with your handheld monitor for H₂S and lower explosive limit (LEL), ensuring your roadblock is not too close to the edge of the EPZ. Record readings on the Air Quality Monitoring Log.
- Notify the Public Protection Group Supervisor once your roadblock is set up.
- Continue to monitor and record H₂S and LEL levels at scheduled intervals. Report to the Public Protection Group Supervisor at scheduled intervals.
- Maintain roadblock until the emergency is over and the stand down declaration is given or until relieved by other roadblock personnel.

To give motorists time to prepare to come to a stop, it is recommended that the roadblock personnel setup all available reflective triangles 100 metres apart, at a minimum distance of 200 metres before the roadblock.

Roadblock Statement

Hello, my name is _____ (state your name).

I am representing NorthRiver Midstream Inc.. NorthRiver is presently experiencing control problems ahead. This situation is serious enough to warrant restricted access beyond this point and therefore I am requesting you take an alternate route.

Note: Confirm evacuation route and evacuation orders with Public Protection Group Supervisor prior to directing traffic on an alternate route

7.6 Evacuation or Shelter in Place Procedures

Evacuation and Shelter-in-Place:

- **Evacuation Procedures:** Develop clear evacuation routes and procedures for all response zones. Ensure that transients, such as hunters, trappers, recreational users, and non-resident landowners, are accounted for and evacuated.
- **Shelter-in-Place Instructions:** Provide detailed shelter-in-place instructions, including sealing windows and doors, turning off ventilation systems, and staying indoors until further notice.

Special Procedures for Public Facilities:

- **Evacuation of Large Groups:** Address special procedures for evacuating public facilities involving large numbers of people. Arrange for transportation assistance, such as school buses, and modify notification procedures to ensure timely evacuation.
- **Notification Systems:** Implement robust notification systems to alert the public and facilitate evacuation.

Consultation and Notification Outside EPZ:

- **Consultation Summary:** Discuss and document how notification and evacuation will occur outside the EPZ in consultation with appropriate authorities. (Include a summary of these discussions in the ERP.)
- **Objective:** To ensure effective communication and coordination with appropriate authorities and the public outside the EPZ during an emergency incident.

Procedure:

Coordination with Authorities:

- **Emergency Services Coordination:** Coordinate with local emergency services to manage traffic, evacuations, and public safety measures outside the EPZ.
- **Public Health Coordination:** Work with public health authorities to address potential health impacts and provide guidance on protective actions.
- **Transportation Coordination:** Collaborate with transportation authorities to manage road closures, detours, and public transportation assistance.

7.6.1 General Shelter in Place Procedures

The following steps should be communicated to the public if individuals are asked to shelter in place:

- Immediately gather everyone indoors and stay inside.
- Close and lock all windows and outside doors.
 - If convenient, tape the gaps around the exterior door frames.
- Extinguish indoor wood burning fires.
 - If possible, close flue dampers.
- Turn off appliances or equipment that either:
 - Blows out or uses indoor air, such as:
 - Bathroom and kitchen exhaust fans.
 - Built-in vacuum systems.
 - Clothes dryers.
 - Gas fireplaces.
 - Gas stoves.
 - Sucks in outside air, such as:
 - Heating ventilation and air conditioning (HVAC) systems for apartments, commercial or public facilities.
 - Fans for heat recovery ventilators or energy recovery ventilators (HRV/ERV).
- Turn down furnace thermostats to the minimum setting and turn off air conditioners.
- Leave open all inside doors.
- Avoid using the telephone, except for emergencies, so that you can be contacted by emergency response personnel.
 - Call the Company emergency number that you have been provided:
 - If you are experiencing symptoms or smelling odours (so that we can address your concerns and adjust our response priorities).
 - If you have contacted fire, police or ambulance (so that we can coordinate our response).
- Stay tuned to local radio and television for possible information updates.
- Even if you see people outside, do not leave until instructed by response personnel.
- If you are unable to follow these instructions, please notify the Company's emergency response personnel.

7.6.2 Post Shelter in Place Procedures

Once the emergency situation has been corrected you will receive a communication from the emergency response personnel. Advise the residents/area users/stakeholders to:

- Ventilate the building.
- Open all windows and doors.
- Turn on indoor fans.
- Turn on the furnace.
- Avoid remaining inside during this time (if possible) as the outdoor air may be fresher.
- Once the building is ventilated, return all heating, ventilating and other equipment to normal.

7.7 Health and Safety Plan

The Health and Safety Plan for a hazardous material spill highlights the critical information about the product, physical location of the spill and other incident-specific conditions required by responders to respond safely to the incident, as well as appropriate safety rules and precautions that will be enforced at the scene.

In most circumstances, the Health and Safety Plan for a specific incident should be prepared by a Site Safety Officer at the scene who is in a position to conduct a thorough, accurate hazard assessment.

The Health and Safety Plan should be concise, and written in clear, non-technical language to ensure understanding by responders.

The Health and Safety Plan outlines the key hazards associated with the incident, and the safety procedures and precautions that are to be enforced during the response. As the response progresses, the Health and Safety Plan should be updated on a regular basis to reflect changing conditions at or near the scene of the incident.

The Incident Commander is responsible for reviewing the Health and Safety Plan. The Site Operations Section Chief and On-Site Group Supervisor are responsible for implementing and enforcing the safety requirements of the plan throughout the response.

7.7.1 Product Specific Information

Product Hazards:

- Poisonous or toxic.
- Flammability.
- Corrosive.

Health Hazards and Risks:

- By ingestion.
- By direct contact, skin.
- By inhalation.

Critical Behaviours and Properties (as required by the situation):

- Vapours heavier or lighter than air?
- Sinks, floats, dissolves or evaporates in water?

Other:

Risk of Fire or Explosion:

- Flash Point.
- Lower Explosive Limit (LEL).
- Upper Explosive Limit (UEL).

**Exposure Limits
(ACGIH – if other specify):**

- TLV-TWA.
- TLV-STEL.
- TLV-C.

7.7.2 Responder Safety and Protection

Responder Qualifications/Training Requirements:

Recommended Level of Personal Protective Equipment (PPE):

- Level A (specify equipment).
- Level B (specify equipment).
- Level C (specify equipment).

7.7.3 Site-Specific Information

Drawing, map or sketch of the incident site showing:

- Key topographical features (e.g., buildings, natural features).
- Initial Isolation Zone.
- Protective Action Zone.
- Potential Downwind Evacuation Zone.
- Wind Direction.
- Real and potential vapour monitoring points.
- Security Access Points (if applicable).
- First Aid stations (if applicable).
- Command Centre and Staging Areas (if applicable).

Note key features of the location that might affect the safety of responders.

Describe proximity to:

- Populated areas (e.g. residential or commercial).
- Bodies of water (e.g. lakes, rivers, streams, ocean).
- Environmentally sensitive areas.

7.8 Public Safety and Protection

During any emergency involving Company assets, the Company maintains full responsibility for ensuring public safety, consistent with regulatory requirements. Local authorities may assist and exercise their statutory powers; however, their involvement does not transfer or diminish the Company's responsibility.

In many foreseeable situations, local authorities, such as:

- Police
- Fire Departments
- Municipal Emergency Management personnel
- Public Health officials

may choose to undertake or support public protection measures (e.g., evacuation, shelter-in-place, advisories, traffic control). These actions are carried out within their jurisdictional authority and in coordination with the Company's Incident Command.

Local authority actions may range from no intervention (if no public risk is present) to issuing public warnings, health alerts, or ordering partial or full evacuations in the affected areas.

The Company will lead the assessment of hazards and risks associated with the incident and will provide timely, accurate, and complete information to support local authority decision-making, including but not limited to:

- Physical and chemical properties of released substances
- Toxicological properties and associated health risks
- Critical parameters such as exposure limits, flash point, and explosive limits
- Behaviour of released substances on land, water, or in vapour form

7.9 Site Security

Site security describes security measures that are designed to deny unauthorized access to facilities, equipment and resources, and to protect personnel and property from damage or harm (such as espionage, theft, or terrorist attacks). Site security involves the use of multiple layers of interdependent systems which includes Closed-Circuit Television surveillance, security guards, protective barriers, locks, access control protocols, and many other techniques.

7.9.1 Safety

The safety of facility personnel is paramount during periods of elevated security risk. Facility personnel have the right to ensure the safety of their fellow employees, prevent damage to facility property and prevent harm to trespassers but do not have the authority or permission to confine persons trying to leave the property.

Response Plan for Site Security

- Call 911.
- Assess the threat risk versus the ability to safely continue the facility operations.
- Conduct a team meeting to include all facility personnel apprising them of the threat potential, an assessment of its legitimacy and include precautionary and egress measures.
- Advise facility support companies and contractors of the threat potential and the precautionary measures.
- Remain and operate in pairs during periods of elevated security risk, each team should be provided with a reliable means of communication.
- The facility gates should be closed and remain closed.
- When risk assessment deems it appropriate, anyone entering or exiting must be identified and the date and time documented by security.
- During periods of elevated security risk and continued operation, facility management shall coordinate the travel plans of personnel to and from the facility.
- In the event that the threat is assessed to be credible and provides potential for injury to facility personnel, consider operational shutdown and the initiation of either a controlled proactive evacuation or shelter in place.
- Consider the initiation of two-person security patrols throughout the facility.
- Confer with Company management with regard to acquiring security support.
- Do not attempt to challenge unauthorized persons who appear to be armed or significantly distraught.
- Ensure that none of the security measures restricts safe and immediate egress from the facility in the event of an emergency evacuation.
- Consider the postponement of all non-essential facility activities until an appropriate reduction in the security risk has occurred.

In the event of civil disobedience or ideological protest, facility personnel are directed as follows:

- Do not attempt to engage the protestors in anyway.
- Do not enter into discussions or verbal conversation.
- The On-Site Group Supervisor is to identify and communicate alternate egress routes from the facility in the event of emergency.
- Facility personnel should be sheltered away from the protestors as is possible to limit exposure.

7.9.2 Cyber Security

A Cyber Security Incident Response Plan ensures the organization can quickly identify, contain, and recover from digital security incidents that may disrupt operations or compromise sensitive information. It outlines clear roles, communication protocols, and immediate actions to reduce impacts and support continuity across essential services during an emergency.

If an employee knows or suspects a cyber security attack has occurred or is imminent, the incident must immediately be escalated to the internal IT emergency contact number 1-877-668-0897. The Cyber Security Response Action Plan will then be initiated by internal IT personnel.

7.10 Injury/Fatality

All personnel must be prepared to provide timely and effective response to preserve the health and safety of personnel injured due to an emergency event. Always consider the consequences and risks prior to taking response actions to assist a victim and providing medical assistance. Ensure that the rescuer does not become a victim.

If an incident involving equipment results in the death of a worker, the person who is in charge of the equipment must ensure the site of incident is not disturbed, unless:

- Protecting the health and safety of other personnel.
- Aiding an injured person involved in an incident.
- Taking essential action to make the scene safe or to prevent a further occurrence of the incident.

The On-Site Group Supervisor has the obligation to preserve the site intact until:

- An OHS inspector or police officer arrives at the site of incident.
- Or an OHS inspector or police officer directs otherwise at the time of notification.

7.10.1 Serious Injury/Fatality Safety

- Assess the incident site for hazards, consider the following hazards before proceeding to the victim:
 - Hazardous gases (H₂S, carbon monoxide, etc.).
 - Electrical.
 - Uncontrolled pressure.
 - Unsecured mechanical.
 - Liquid.
 - Fire and explosion.
 - Unsecured suspended loads.
 - Other unsafe conditions.

If at any time the scene is deemed unsafe to enter:

- Do not enter or approach the victim.
- Responders are to immediately return to a confirmed safe area.
- Conduct any mitigating actions that are possible from a safe area.
- Wait for assistance if unsafe conditions remain.
- Identify the mechanism of injury and establish control mechanisms (water spray, electrical de-energizing, etc.).
- Identify the victims that will require decontamination prior to medical treatment.

7.10.2 Action Plan for a Serious Injury/Fatality

Identify the Emergency Event Occurrence

- Notify facility personnel of an emergency event occurrence.
- Sound a facility wide alert.
- Identify the location of the emergency event.
- Provide initial personnel actions to ensure their safety.

Direct Facility Personnel

- Communicate the presence of uncontrolled hazards to facility personnel.
- Provide direction to facility personnel for ensuring their safety.
- Specify and assign personnel to safe mustering positions.
- Identify the safe access routes from, or around, areas of hazard, to the safe mustering positions.
- Account for all facility personnel.

Initiate External Emergency Response

- Call 911.
- Request medical aid and transport.
- Identify incident location.
- Provide a call back number.
- Provide basic injury information.
- Provide known event timeline.
- Identify hazards present.

Brief Personnel Tasked to Assist in Hazard Stabilization

- Current incident site conditions.
- Uncontrolled hazards.
- Hazard control priorities.
- Provide individual assignments.
- Identify personnel safety considerations during stabilization operations.
- Specify communication and coordination protocols for stabilization operations.
- Review critical considerations of individual tasks.
- Specify emergency evacuation plan.

Stabilize Hazards and the Incident Site

- Remove or control incident scene hazards.
- De-energize/safety equipment and power supplies.
- Isolate uncontrolled material releases.
- Remove sources of ignition.
- Lower elevated or suspended loads.
- Identify any areas of, or remaining scene hazards.
- Monitor, direct and coordinate stabilization operations.
- Monitor safety conditions in areas of stabilization operations.
- Monitor condition of and impact on the injured.
- Maintain effective communication with all intervening personnel.
- In the event that significant hazardous conditions remain uncontrolled, consider the activation and assignment of the Site Safety Officer.

Approach and Assess the Injured

- Approach the injured and check for signs of life.
- Confirm the total number of injured.
- Identify injuries present.
- Triage the injured: identify and prioritize the injury treatment based on criticality of need.
- Assess the safety of field treatment in the position found.
- Assess the ability or effectiveness of field medical treatment in the position found.
- Confirm the accountability of facility personnel versus known numbers on site:
 - Safe mustering position.
 - Tasked for stabilization.
 - Medical treatment.
 - Injured.

Assess the Need for Chemical Decontamination

- Identify the need to decontaminate injured prior to initiating field medical treatment.
- Identify the chemical exposure.
- Reference applicable SDS.
- Contact the chemical manufacturer to obtain additional decontamination/ neutralization information.
- Contact Company Corporate Health to advise.
- Contact the Canadian Transport Emergency Centre (CANUTEC) for assistance.

Provide Field Medical Treatment

- Provide chemical decontamination/neutralization prior to initiating field medical treatment.
- Stabilize injured in position found if possible.
- In the event that the injured must be moved:
 - Mark the position found.
 - Create a sketch.
- Provide medical treatment only within level of training.
- Ensure qualified personnel provide field medical treatment within prioritized medical aid protocols.
- Closely monitor injured until relieved by arriving emergency responders.
- Maintain appropriate confidentiality of incident, medical and injured personal information.

Provide Company Management with Incident Notification

- Provide event timeline.
- Provide total number of injured.
- Provide names of injured.
- Provide specific injuries.
- Provide ages of injured.
- Provide employers of injured.
- Provide job description of injured.
- Provide contact information of injured.
- Provide current medical status.
- Identify field medical treatment provider.
- Identify medical transport provider.
- Identify receiving hospital – trauma center.
- Provide next of kin contact information.

Meet and Brief Emergency Responders

- Position personnel to meet and direct emergency responders to the incident site.
- Provide a scene safety and hazard briefing.
- Identify the mechanism(s) of injuries.
- Provide an event timeline.
- Identify the number of injured.
- Identify the initial position and condition of each victim.
- Identify the injuries sustained by each victim.
- Identify the medical treatment provided.
- In the event of a victim chemical exposure:
 - Identify any decontamination provided.
 - Provide an SDS.
- Provide personal information for each victim.
- Assist emergency responders within ability and level of training.
- Monitor the safety of the incident site.
- Gather information regarding the medical treatment provider, the transport provider and the destination medical center, hospital or trauma center.

Special Considerations for Fatality Events

- The deceased must not be moved unless:
 - Doubt of death exists, or
 - Authorized/requested to do so by the medical examiner or designate.
- If the victim's injuries are obviously fatal no additional risk shall be taken to recover the body.
- The recovery of suspected fatalities does not take priority over the rescue of the living and incident control activities.
- Scene preservation is critical – lawful movement of a fatality is only permitted to rescue a person in danger or to establish area safety.
- Once the emergency event has been controlled, the area of a suspected fatality is to be cleared of all personnel and cordoned off.
- Institute a tracking log to account for all persons with access to the cordoned off area.
- Non-authorized pictures are prohibited.
- Police and OHS will attend to conduct investigations.

Provide Field Management of the Incident

- Isolate and maintain the incident site undisturbed until custody is handed over to the investigating agency.
- Re-evaluate the overall safety of the facility.
- Assess, monitor, and manage the individual condition of the uninjured facility employees.
- Interview witnesses to the incident, providing a written statement, immediately if possible, or delayed if the witness is physically or emotionally unable.
- Receive approval from Company management prior to re-establishing site operations.

7.10.3 Next of Kin Notification

If any personnel are seriously injured, missing or killed, it is the responsibility of the Incident Commander to ensure that NorthRiver provides prompt notification to a senior Company representative so that the immediate family can be notified as quickly as possible.

Next of Kin Notifications should be made in the following instances:

- A serious injury.
- A fatality.
- Instances where personnel may be involved in an emergency and are unharmed, but are not able to contact family members to advise of their status.

Death should never be declared by NorthRiver no matter how obvious. Death notifications are not to occur until a medical doctor or medical examiner with the local authorities has pronounced the casualty legally dead.

If the incident involves the death or serious injury of a member of the public, local police or RCMP will be contacted by the Incident Commander (or designate) and asked to identify and notify the next of kin.

Under no circumstances are the names of casualties or missing persons to be released to the public or media unless next of kin are notified and their consent is obtained.

Contractor Next of Kin Notification

If an employee of a contractor employed by NorthRiver is injured, the Incident Commander and a senior Company representative will ensure that the contractor's head office is notified. The Contract Company is responsible for their own employees' notification of Next of Kin. In the case where a contractor is a small operation, or with no office, NorthRiver will request that the RCMP or local police identify and notify the next of kin.

Employee Next of Kin Notification

If an employee or contract employee employed by NorthRiver is injured, a senior Company representative or the most senior company field representative known by the family will make Next of Kin notifications in conjunction with a Victims Services representative from the local police or RCMP detachment.

7.11 Missing Worker

If a member(s) of staff does not attend work during a scheduled shift and contact cannot be made, the On-Site Group Supervisor should assess the situation and decide whether to activate the Emergency Response Team.

Where it is determined that a worker is potentially missing the Emergency Response Team is to be activated to assist in determining their whereabouts and in mobilizing company personnel.

7.11.1 Response Plan for Missing Worker

- Attempt to establish contact with the missing person(s) by phone.
 - Leave a voicemail message with a provided call back number.
- Establish a history of the missing person(s) last known movements, by contacting colleagues, friends, family, contacts, and work associates.
- Identify the missing person(s) personal vehicle and attempt to locate vehicle on site or in proximity to his/her last known movements.
- Make enquiries with local/county/regional/state hospitals.
- Make enquiries with local/county/regional/state police.
- Continue to try to establish contact with the missing person using:
 - Mobile telephone number(s).
 - Home telephone number.
 - Text messages.
 - Email messages.
- If the missing person is a contractor:
 - The contracting company shall be contacted to determine if they know of the person's whereabouts or movements.
 - Continue to maintain regular contact with contracting company.

7.12 Air Ambulance

7.12.1 Command Control

Air Ambulances are dispatched based on flight conditions, aircraft availability/capability and criticality of the injured. Once you believe that an air ambulance is needed, call the appropriate number identified in the Telephone Directory in this binder and provide:

- Description of the patient's condition.
- Severity of injury.
- Type of injury.
- Level of consciousness.
- Exposure to hazardous materials.

If possible, establish contact with helicopter crew on a secure, dedicated radio frequency and remain in contact until touchdown. Identify the pre-designated Landing Zone if available.

All Landing Zone personnel must wear full PPE including, helmet, glasses, ear protection and a high-visibility vest.

Pre-Landing Checklist:

The flight crew will contact ground units via a prearranged radio frequency, ambulance radio frequency, or phone line for the following information.

TERRAIN	HAZARDS	LZ Markings
Level or sloping	Street signs	Four turbo flares
Type of surface	Vehicles	Four road flares
Dust or loose snow	Towers	Four reflective flares
Rocks, bushes, stumps, etc.	Poles	Four highway cones (days only)
	Wires	(Extra strobes/flares/cones on upwind side)

7.12.2 Landing Zone

When choosing a landing zone, look for the following:

- Flat or relatively level surface.
- Approximately 35 metres (120 feet) downwind from the scene to protect the incident from any downwash and exhaust.
- Ideally 30 metres (100 feet) square in size.

Sweep the site for all foreign unsecured and loose debris and wet the area down to reduce dust or loose debris from dislodging.

Communicate hazards (typically through the Air Ambulance dispatch) using the mnemonic **HOTSAW**:

- Hazards.
- Obstructions.
- Terrain.
- Surface.
- Animals.
- Wind/weather.

The landing zone should be marked on all four corners by either bright LED lights, or traffic cones.

7.12.3 Ground Operations

- Designate a Landing Zone Operator (LZO).
- When helicopter approaches the LZO will extend both arms straight above their head, giving the 'all-clear' signal.
- If there are any sudden changes or if any hazards arise the LZO simply waves off the landing, communicates the hazards to the crew and then the helicopter crew will assume a holding pattern until it is clear to land.
- The LZO remains in place, in a kneeling position, to act as a horizontal reference point for the pilot.
- For helicopter departure, the LZO again assumes a kneeling position at 12 o'clock giving the 'all-clear' signal for takeoff.

7.12.4 Loading and Unloading

- Do not approach the helicopter.
- The co-pilot will guide all crews nearing the helicopter for patient loading.
- For loading patients, crews must approach the helicopter in the 10 - 2 o'clock positions avoiding the tail rotor of the aircraft.

7.12.5 Hazards and Special Situations

- Landing zone operations and practices are the same for day and night operations.
- For night landings, all emergency personnel in the vicinity of the landing zone must don high visibility vests throughout operations.
- Nearby vehicles can focus lights on hazards in the immediate area but must not direct the lights at the helicopter as they could potentially obscure vision for the crew.
- If the incident is in a remote area turn nearby vehicles lights on to illuminate the landing zone, preferably vehicles should be located at the four corners of the landing zone.
- If the landing zone is covered in snow or partially obscured take up position in the centre of the landing zone and the pilot will land directly beside the LZO using them as a reference point.
- For road landings, all single lane highways or roads, traffic must be blocked in both directions throughout both the aircrafts' landing and take-off procedures work with the local police or highway authorities with jurisdiction.

7.12.6 Approach Routes

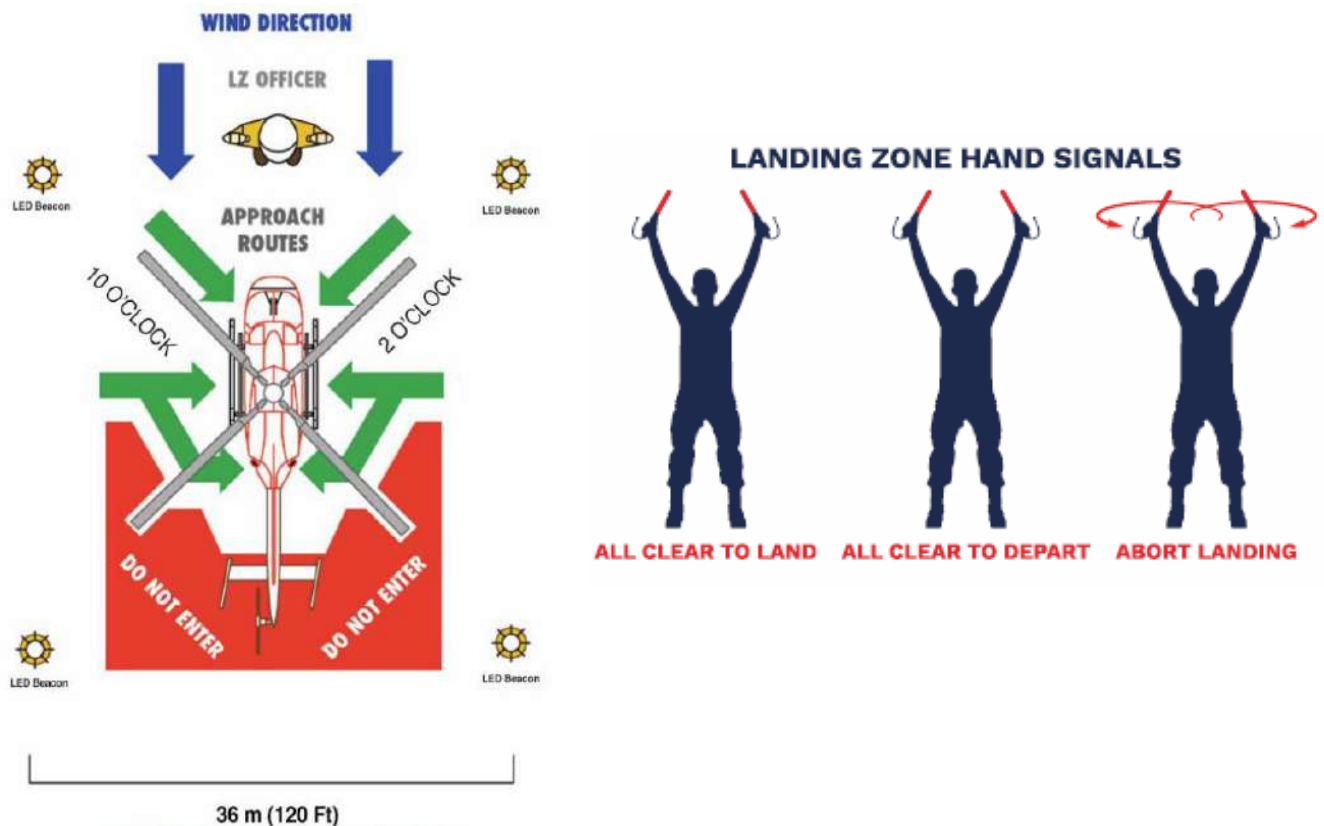

Incident Specific Initial Response Actions and Procedures

The following Response Action Plans and Procedures are designed to address specific incident types.

7.13 Spill Contingency Plan

The purpose of this Spill Contingency Plan is to define procedures for responding to discharges of petroleum or refined products that flow offsite and/or that impact surface water features such as drains, wetlands, ponds, or creeks.

The objective of the procedures described in this Spill Contingency Plan is to protect the public, Company personnel, and other responders during spills or releases and clean-up operations. In addition, the Spill Contingency Plan is intended to minimize damage to the environment, natural resources, and facility installations from a discharge.

This Spill Contingency Plan describes the responsibilities and procedures for responding to a petroleum or refined products discharge and performing clean-up operations.

7.13.1 Spill Preparedness Risk Analysis

The risk analysis is the identification of potential spill sources and product types from a company's operations, the potential hazards that could result from an uncontrolled release and the determination of the vulnerability of an area should a spill occur. The possibility that a spill could occur under all conditions in a given area must be anticipated. In terms of spills, higher risk operations are often linked with having facilities and/or transporting products in close proximity to the public and environmentally sensitive area including those areas that have surface water.

A typical risk analysis of a company's operations includes the following components:

- An evaluation of products handled in terms of their characteristics during an uncontrolled release as well as their impact on people, property and the environment.
- Familiarization with the environmental sensitivities around facilities and in areas where the products are handles and/or transported.
- Compliance with legal and company requirements (i.e. laws and regulations, industry standards, policies, procedures and guidelines).
- Review of construction and maintenance procedures.
- Evaluation of the spill prevention program.
- Review of the company emergency response plan and spill contingency plan.
- Evaluation of the overall company's response capability for each area of operation.

7.13.2 Seven Step Guideline for Spill Response

For specific spill volume thresholds and reporting requirements, see the applicable Jurisdictional Section in this ERP.

Step 1 – Collect and Document Spill Reporting Information

One of the first steps in a spill response will be to collect and document spill-reporting information. This emergency response plan has a spill report form that can be used to collect critical information. Ensure that staff are familiar with the spill report form and know who to pass information on to. Information documented on the spill report form will be used to notify initial spill responders, company contacts and where appropriate, government and land contacts. It is important to ensure that a contact number is recorded for the person that reports the spill and that there is follow-up contact with that person. Typical information on a spill report form includes:

- Person reporting and contact numbers.
- Operator, company and/or licensee information.
- Date and time of incident.
- Type and volume of the spilled product (product identification number if available).
- Incident cause.
- Incident location and site description.
- Safety concerns.

- Environmental issues.
- Level of emergency.
- Public concerns issues.
- Spill response activities.
- Contact information.

Responder tools will depend on the types of spills. If an employee has been identified as having a spill response role, it is important that he/she has quick access to initial response tools including:

- An emergency response plan or key information (e.g. contact lists, resource lists, access and control point maps) extracted from the plan.
- Communications equipment.
- Appropriate personnel protective equipment including a personal and/or electronic monitor (gas detector).
- Recording equipment (e.g. notebook, pens, and camera).
- Portable barriers and/or hazard warning ribbon.
- A compass and measuring equipment (e.g. topofil, tape measurer).
- Personal items (e.g. water, extra clothing, snacks, etc.).
- Wind indicators (e.g. portable windsocks, Teflon tape).

In addition, it may be of value to have access to some basic spill containment and sampling equipment including:

- Shovel.
- Rubber mat and/or plastic to cover storm and/or sewer drains and plywood to block culverts.
- Sorbent booms.
- Basic patching equipment for container leaks.
- Sampling equipment and containers.
- Quantabs for assessing salinity at produced water spills.

Step 2 – Dispatch Initial Responders to the Incident Site

Following the notification of the incident dispatch initial responders to the spill site to:

- Verify that there is a spill.
- Gain site control.
- Assess the incident.
- Make appropriate contacts.
- Develop an incident action plan.
- Isolate the leak.
- Initiate containment and recovery if safe to do so.

On route to the site, responders should consider how they would safely approach the area to minimize exposure. In general, the site should be approached from upwind and from high ground if possible, with appropriate PPE and detection equipment.

Three important things for responders to remember during the initial response are:

1. To protect the lives and well-being of spill responders.
2. Initial responders must only attempt what they are capable of doing safely.
3. Sounding the alarm with a call for help should be anticipated.

HELP! Where from?

- Internal resources.
- Other companies.
- Government agencies.
- Fire departments.
- Police.
- Ambulance.
- Contractors.
- Spill specialists.

It will be important that the response team have pre-determined organizational structure with a spill response team leader and that each member clearly understands his/her role. The initial response team should be organized so that they work in pairs (buddy system) prior to taking any action on-site. Good, clear communications within the initial response team is critical. If additional help is required, the initial responders should identify a practical meeting location that can be used as a staging area for manpower and equipment.

Step 3 – Arriving at the Spill Site – Site Control

One of the most critical steps once the responders arrive on the incident scene is for them to take control of the site. It is essential to keep all personnel out of the hazardous area until the identification of the nature and degree of hazards is known, and the initial assessment completed. This includes not only hazards from the spilled material but other physical hazards such as power lines, etc. Although no two spills are the same and not all of the assessment information is immediately available, the following general sequence of site control techniques is common during a disciplined spill response:

- Verify who is in command.
- Identify the emergency planning zone which is the area of greatest concern related to the hazards associated with the event.
- Secure all non-essential personnel from the emergency planning zone and identify the emergency planning zone with ribbon and/or barricades if possible.
 - This step could include the evacuation of a large number of people and outside assistance will likely be required.
- Identify an entry and exit checkpoint at the periphery of the emergency planning zone to regulate the flow of personnel and equipment.
- Control all access to the emergency site by adding a contamination reduction zone which is a transitional or buffer area and a support zone which is a clean area for the On-Site Command Post (OSCP), equipment, staging, etc.
- Identify a safe area within the contamination reduction zone to remove contamination from response personnel, their clothing, and equipment.
- Eliminate all potential ignition sources if safe to do so.
- Identify an emergency signal, escape routes, and a meeting location for response personnel.
- Place wind indicators at appropriate locations.
- Ensure responders understand the issues related to site management and understand their role.

If there is an injury at the spill site when the responders arrive it may be necessary to provide primary care to the injured persons until medical professionals arrive. In remote areas, it may be advantageous to consult with a physician via radio or phone and provide care for the injured during the transferring of the injured to medical professionals. It is extremely important that responders do not take an unreasonable risk when attempting a rescue operation at the incident site.

Step 4 – Situation Analysis

Following their arrival on-site, the response team will conduct an assessment of the spill, sometimes referred to as a situation analysis. The analysis can be broken down into smaller components as follows:

- What is the problem?
- What variables can affect it?
- What are the potential losses and critical issues?
- What is needed to protect response personnel?

The Problem?

Analyzing the problem means looking at the quantity and nature of the material, type and behavior of the container and stage of incident.

- Identify the spilled substance.
- Identify of the hazards associated with the uncontrolled release.

Sources of Information Include:

Operator Knowledge: The owner of the spilled material is a good source of information related to product identification, characteristics of the material and typical hazards associated with an uncontrolled release. The owner also has access to Safety Data Sheets (SDS) and an emergency response plan.

Shipping Documents: If the spill is linked to a transport vehicle, shipping documents or a waste manifest will be in the road vehicle within reach of the driver (i.e. seat or door pocket). The shipping document will outline contact information, a description of good carried, quantity of goods and an emergency response telephone number.

Safety Marks/Labeling: Placards (250 mm x 250 mm) used to identify loads over 450 litres, labels (100 mm x 100 mm) used to identify product in smaller containers and safety marks provide visual clues related to the identification and hazards associated with the spilled product. An international system of safety marks that responders should be familiar with includes:

- **Class Number:** Eight classes of dangerous goods are identified including; Class 1-Explosives, Class 2-Gases, Class 3-Flammable Liquids, Class 4-Flammable Substance, Class 5-Oxidizers/Organic Peroxides, Class 6-Toxic/Infectious Substances, Class 7-Radioactives, Class 8-Corrosives, Class 9-Miscellaneous
- **Colour:** The color of the safety mark will also provide clues as to the type and hazard associated with the material; for example, red indicates that the product is flammable.
- **Number:** A United Nations (UN) number, a four-digit number has been assigned to all dangerous goods; for example, gasoline is UN 1203, diesel fuel is UN 1202, and crude oil is UN 1267.
- **Container Identification:** The size and shape of the container involved in an uncontrolled release can also provide responders with a visual clue related to that container's contents.

Emergency Response Guidebooks: These guides help the responder identify the material by listing all of the United Nations (UN) numbers and linking the number with the name of the material and/or listing the materials in alphabetical order. The guidebook also provides a general guideline on potential hazards, public safety issues and emergency response considerations for each of the materials listed in the book. In addition, the guide includes initial isolation and protective action distances that can be used to zone a spill site (i.e. flammable liquids isolate spill for at least 25 to 50 meters in all directions).

Computer Databases: Countries maintain emergency response telephone numbers where the responder can obtain specific information regarding the spilled substance.

In terms of quantity, responders should be concerned with both the amount of product spilled and the amount that could be spilled. The type, condition and behavior of the container will help responders estimate spill volumes and forecast potential problems.

Variables That Affect the Spill: There are three primary variables that have an impact on a spill including the location of the spill, the time the spill occurs, and weather conditions. It is important to remember that no two spills are the same and that these variables can affect the spill in many different combinations.

Step 5 – Documentation and Information Management

Documentation of the incident is extremely important and should be initiated early in the response and maintained throughout the event. Documentation requirements will depend on the nature of the incident and should include the following:

First Report: Date and time of the release, location of the point of the release, composition of the release, quantity of spilled substance, release cause, circumstances leading up to the event, and initial response activities.

Spill Response Organizational Structure: Outline of the organizational structure with contact information.

Site Description: Spill sketch, photos, and map.

Event Records: Chronological record of events.

Safety: Findings of initial hazard assessment, safety controls, safety meetings, worker requirements, safety orientation, incident reporting, equipment, and resources.

Environmental Issues: Sensitivities, sampling information, waste management plan, etc.

Negotiations and Agreements: Internal company representatives, regulatory, and third-party contractual agreements. It is also important to maintain detailed records of site visitors, their contact information, reason for visit and specific details related to their involvement.

Incident Action Plan: An overview of the issues and plan to deal with those issues.

Regulatory Spill Reporting: Regulatory spill reporting requirements, located in Section 9, are dictated by the type of spill, the spill volume, and the location of the spill. Non-compliance related to spill reporting usually leads to enforcement action and substantial fines.

Type of Spill: In most jurisdictions an upstream petroleum-based spill is reported to the lead Regulatory Authority. Refined product spills and chemical spills are reported to the environmental agency. There is normally a memorandum of understanding between the Regulatory Authority and Environmental Agency related to ensuring that they advise each other of appropriate incidents. If the spill is caused by a transportation incident and the spilled product is regulated under the Transportation of Dangerous Goods Act, it is a requirement to report the incident to police as well.

Spill Volume: Provincial/State legislation identifies the minimum volume of spilled material that must be reported. In transportation-based spills where the product is TDG regulated, the minimum spill volumes are outlined in the Transportation of Dangerous Goods Act and Regulations.

Location of Spill: If the spill is not reportable because the volume is less than the reportable volume, but the spill causes an adverse effect (negatively impacts people, property, and/or environment) it is considered a reportable spill.

Step 6 – Developing the Incident Action Plan

Once the spill responders have control of the site and have completed the assessment, they should develop and document an incident action plan. The plan will identify spill issues and outline tactical objectives for dealing with the issues. The following is an example of some of the issues that could be included in an incident action plan:

- Emergency conditions.
- Hazards, risks and assessment information.
- Issues identification.
- Safety controls.
- Response objectives, tactics and alternative options.
- Resources.
- Organizational structure.
- Names of individuals and agencies participating in discussions.
- Waste management.
- Sampling and analysis.

The incident action plan is subject to change. The response team evaluates the incident on a continuous basis and new spill issues are introduced as the incident progresses. It is important that responders review the plan on a frequent basis, make changes if appropriate and ensure that stakeholders are aware of those changes.

Step 7 – Implementation of Response Objectives

Once the incident action plan has been developed, the response team will implement response objectives. The incident will be handled offensively, defensively or by non-intervention.

- Offensive tactics require responders to control and/or mitigate the incident within the higher risk areas of the event. Safety controls must be in place to undertake offensive tactics.
- Defensive tactics allow responders to control/mitigate the emergency remote from the higher risk (i.e. installing barriers to prevent product from migrating into sensitive areas, deploying boom at downstream control points, etc.).
- Non-intervention refers to responders taking limited action at the emergency site, normally additional resources arrive.

7.13.3 Company Spill Discovery and Response Actions

The Company has the primary responsibility for providing the initial response to spills and releases originating from one of their wells, facilities, or pipelines. To accomplish this, the Company has implemented the Incident Command System (ICS), developed response plans, and completed training to respond to a spill or release event. The Incident Commander plays a central coordinating role in any emergency situation.

The Incident Commander will direct notifications and initial response actions in accordance with the company Emergency Response Plan, training, and capabilities.

Discharge Discovery and Source Control

Upon discovery of a leak or spill the following actions should be taken:

- Immediately report the discharge to the Company Supervisor, providing the following information:
 - Exact location
 - Material involved
 - Quantity involved
 - Topographic and environmental conditions
 - Circumstances that may hinder response
 - Injuries, if any
- Turn off all sources of ignition.
- Locate the source of the discharge.
- Turn off all equipment related to the incident that could add to the impact of the release.
- If safe to do so, isolate the affected equipment by closing off the closest valves upstream and downstream from the discharge source.

Assessment and Notifications

Notifications to the appropriate Regulatory Authority must occur after the discovery of reportable discharges. The reporting clock starts when the first company or contract employee discovers the discharge.

- Investigate the discharge to assess the actual or potential threat to human health or the environment. Also consider:
 - Location of the discharge relative to receiving water bodies (drainages, creeks, or streams)
 - Quantity of spilled material
 - Ambient conditions (temperature, rain)
 - Other contributing factors such as fire or explosion hazards
 - Sensitive receptors downstream (wetlands, ponds, or reservoirs)
- Request outside assistance from local emergency responders, as needed.
- Evaluate the need to evacuate the facility and evacuate employees, as needed.

- Assess whether community evacuation is needed. Notify the local authority, fire/police for assistance, as needed.
- Contact Company Supervisor to determine if Regulatory Authority notifications are required.
- Communicate with property owners regarding the discharge and actions taken to mitigate the damage.
- If needed, bring in outside contractors and order recovery equipment such as vacuum trucks and backhoes to stop the flow. Mobilize equipment and resources to the spill site as soon as the need is identified.
- If spilled fluids reach (or threaten to reach) any nearby drainages or surface waters, you may need to notify the local authority, Regulatory Authority fire/police to limit access to the water by local residents until the product has been contained and recovered. Additionally, notify downstream water users of the spill and of actions that will be taken to protect these downstream receptors.

Control and Recovery

The Incident Commander directs the initial control of the release and other contractor personnel. The actions taken will depend on whether the product has reached water or is confined to land. All effort will be made to prevent the release from reaching water.

If the product has not yet reached water:

- Deploy sandbags and absorbent socks down gradient from the product, or erect temporary barriers such as trenches or mounds to prevent the product from reaching water.
- Implement land-based response actions (countermeasure) such as digging temporary containment pits, ponds, or curbs to prevent the flow of product into any water.
- Deploy absorbent sock and absorbent material along the water line to prevent product from entering waters.
- Contact clean-up contractor(s).
- Deploy floating booms immediately downstream from the release point.
- Control product flow on the ground by placing absorbent socks and other absorbent material or physical barriers (e.g., kitty litter, sandbags, earthen berm, trenches) across the product flow path.
- Deploy additional floating booms across the whole width of the affected waters at the next access point downstream from the release point. Plan ahead and access the stream or waters from safe locations.
- Deploy protective booming measures for downstream receptors that may be impacted by the spill.

Spill Clean-up/Mitigation/Reclamation

Once the pipeline break or leak has been located and isolated and the area has been secured, the following procedure should be followed.

- Determine if there are any other pipelines or utilities within 30 metres of the break or leak site. If so, the licensee of these lines must be contacted before any ground disturbance occurs.
- Uncover the affected section(s) of pipeline by the safest method. Hand excavation or hydrovac should be used whenever the break is within 5 metres of the pipeline in question or another pipeline until the break or leak is located.
- Expose the pipeline break or leak, ensuring that the proper trenching, back sloping and shoring techniques are used and that a safe route of access and egress is maintained at all times.
- Obtain a sufficient number of samples of effluent to quantitatively determine its physical and chemical properties.
- Drain effluent into a bell hole and remove the impacted soil and waste to an approved disposal site.
- Photographs are to be taken throughout the operation for documentation.
- Refer to the Environmental Regulatory Authority regarding land reclamation standards and requirements.

Decontamination Guidelines

These guidelines are for personnel directly exposed (or suspected of exposure) to oil or chemicals or their vapours, products of combustion, etc. The intention is to provide a general overview of those decontamination situations most likely to be faced by Company responders.

Decontamination areas:

- Will be set up as needed during response operations.
- These areas are to be used for decontamination at the work site.
- They are not to be used as a substitute for personal hygiene prior to arrival.
- Are designed to protect the health of response personnel and to prevent the spread of contamination into 'clean' areas.
- In the field, it will not be possible to remove all contaminated clothing before taking a break from work. It is essential, however, to clean hands and face to avoid inadvertently ingesting oil or spreading contamination to otherwise protected parts of the body.
- In the field, provisions will be made for:
 - Soap, water, paper towels, waterless hand cleaner, and/or other materials for washing hands and feet.
 - Refuse containers.
 - Eyewash station.
 - Safety equipment and clothing as needed.

Full decontamination will be required at the end of the daily shift. Typically, this involves reporting to an area designed for removing contaminated clothing. This must be done carefully to avoid allowing the contaminated clothing to come into contact with the skin or clean clothing. Cleaning stations are used to scrub the body thoroughly in order to remove all traces of chemical or other contaminants. Once fully decontaminated, clean clothing will be put on and contaminated clothing will be cleaned appropriately.

Communications and Control

A Command Post will be set up near the incident site in the event of a discharge. The Command Post will be equipped with a variety of fixed and mobile communication equipment (telephone, cell phones, computers, etc.) to ensure continuous communication with Company management, responders, authorities and other interested parties. Additional equipment will be obtained from the response contractor in the event that more communications equipment is necessary.

The Incident Commander is responsible for communicating the status of the response operations and for sharing relevant information with involved parties, including Company Management; local, provincial and federal authorities.

Disposal of Recovered Product and Contaminated Response Material

The Incident Commander ensures that all contaminated waste materials are disposed of in accordance with all applicable solid and hazardous waste regulations. Contact the Company Supervisor to get guidance on approved disposal locations. In some cases, on-site treatment (bioremediation) may be approved, minimizing costs.

- Place any recovered product that can be recycled into an on-site tank to be separated and recycled.
- Dispose of recovered product not suitable for on-site recycling with the rest of the waste collected at an approved and permitted location.
- Collect all debris in properly labeled waste containers (impervious bags, drums, or buckets or a roll off bin with a liner).
- Collect samples to characterize the waste for shipping and obtain approvals from licensed disposal facilities. Prepare shipping manifests and shipping documents as needed.
- Dispose of contaminated material in accordance with all applicable solid and hazardous waste regulations using a licensed waste hauler and disposal facility.

Termination

The Incident Commander ensures that clean-up has been completed and that the contaminated area has been treated or mitigated according to the applicable regulations and provincial/federal clean-up requirements. In some cases, the spill area soil must be sampled before backfilling can take place. The Incident Commander collaborates with the local, provincial or federal authorities regarding the assessment of damages, as needed.

- Ensure that all repairs to the equipment or pipelines have been completed.
- Review circumstances that led to the spill or release and take all necessary precautions to prevent a recurrence. Apply lessons learned to all operations.
- Evaluate the effectiveness of the response activities and make adjustments as necessary to response procedures and personnel training.
- Carry out personnel and contractor debriefings as necessary to emphasize prevention measures or to communicate changes in operations or response procedures.
- Restock spill response supplies.
- Submit any required follow-up reports to the authorities.

Training Exercises and Updating Procedures

The Company maintains an ongoing training program to ensure that personnel responding to discharges are properly trained and that all necessary equipment is available to them.

Following a response to a discharge, the Incident Commander and Company Management will evaluate the actions taken and identify procedural areas where improvements are needed. The Incident Commander will conduct a briefing with field personnel, contractors, and local emergency responders as needed to discuss lessons learned.

7.13.4 Spill Management Techniques

Spills on Land – Containment

General Containment Procedures

1. If the spill is not flowing or spreading, no containment is required.
2. Use the information gained from the assessment to plan the location of the initial containment measures and determine what type of measures will be required (e.g., booms, sorbents, etc.).
3. Organize and install the containment measures in order of priority to prevent the spill from getting larger and to protect sensitive areas. This will reduce the amount of clean-up work and result in lower clean-up costs and damage settlements. Oil Spill Co-op Contingency manuals should be referred to for the most appropriate containment techniques.
4. Local topography, locations of nearby streams, water bodies, and sewer outfalls, etc., should be taken into account when planning the location of containment berms and dikes. Appropriate Oil Spill Co-op Contingency manuals should be consulted for more information on this subject.
5. Containment berms and dikes should be deployed on land in a manner that will prevent any spilled material from entering a water source. Contingency back-up plans should be developed in case of a breach or failure of a containment structure.
6. If necessary, topsoil should be stripped from areas that will be affected by a fluid spill prior to the spill reaching that area.
7. If necessary, the area around the spill should be fenced off to prevent wildlife and livestock from entering the spill area.
8. If the material is producing flammable or noxious vapours, apply an appropriate foam suppressant to reduce and control the fire/vapour hazard to the surrounding area.
9. In the event of fluid spills breaching existing containment structures, contingency plans should be immediately implemented to prevent any materials from entering streams or water bodies.

Containment Techniques

Sorbing Boom and Blanket

Booms and sorbent blankets may readily contain small spills, especially those that have accumulated on the surface and not infiltrated the soil. Judge the amount of boom needed and assess migration potential based on weather conditions and the topography of the spill area.

Earth Berm

1. Where equipment is available for hand or machine digging, earth berms and containment dikes can be used to contain spills.
2. Suitable soil material (i.e., clay, silt) should be used in the construction of containment dikes and berms. Topsoil material should be stripped and preserved for reclamation procedures.
3. Where soils or surface materials are too permeable to provide adequate containment of spilled fluids, berms/dikes can be fortified with plastic sheeting or sorbent blankets to make the berm less permeable.

Subsurface Trenching

1. Trenches may be contoured to direct, or funnel spilled fluids towards a bellhole or other collection/containment area. If required, trenches and berms may also be constructed upstream of the spill to direct water or run off away from the spill.
2. Where significant subsurface flow of contaminants is anticipated, subsurface trenching will be required to intercept and contain any subsurface flow and direct it towards a bellhole or other low permeability containment area.
3. The specific pattern of trenching depends on the topography and flow regime in the subsurface materials. Trenches are most effective if they can be dug to the depth of the impermeable cemented hard pan or bedrock.
4. The bellhole containment area must be lined or located in impermeable material.

Liquid Spills on Open Ground

1. Spills on open ground are common to the oil and gas industry. Pipeline ruptures during the course of day-to-day operations and overflows of production fluids during well development/ completion activity account for a large portion of these material spills. Once on the ground, the spread of fluids is influenced by local topography and permeability of the soil. These two (2) factors together can make containment and clean-up operations difficult. Spills in areas of high relief can spread considerable distances in a short period of time causing greater aerial impact.
2. Fluid spills in areas with soils having high permeability should be cleaned up quickly in order to reduce the amount of infiltration into soil layers.
3. Spills should be cleaned up from the perimeter towards the centre. Travel through the affected area by equipment or personnel should be avoided at all times.
4. Universal or specific use absorbents can be used to collect spilled material from the containment area. Spill Co-ops can be contacted for information regarding the appropriate uses of available absorbents.
5. Contaminated soil should be excavated and removed to an area where runoff or leaching of the contaminants into the soil can be prevented.

Liquid Spills on Paved Areas

1. In areas of high relief, fluids spilled on pavement may travel rapidly over considerable distances. The viscosity of the fluid, the local relief, and lack of obstructions on the smooth surface will all affect the rate at which the spill will spread. If not contained, spilled materials may enter sewer outfalls and be transported into the local sewage system or into nearby water sources, which would complicate containment and recovery of the spill. This could potentially result in contamination of water sources and wildlife habitat. In such cases it is imperative that spilled materials are contained immediately and diverted away from any sewer outfalls that are within reach of the spill.

2. Spill Co-op procedure manuals can be consulted for the most effective method of containment and clean-up when dealing with particular fluid spills.
3. Location of downstream sewer outfalls, drainage ditches, streams, or water bodies should be determined so that they can be plugged or bermed to prevent spilled material from entering.
4. Foam suppressants should be applied on the spill if dangerous vapours are present.
5. Once contained, clean-up should start immediately. Spilled materials should be moved to collection areas utilizing shovels, scoops, squeegees, brooms, etc., and then removed by vacuum trucks.
6. Appropriate absorbent materials can be utilized to accumulate spilled material that cannot be moved to collection areas. Oil Spill Co-ops should be consulted to determine the most appropriate absorbent material.
7. Used absorbent materials should be stored in barrels or another appropriate container and disposed of appropriately.

Solid Materials Spills on Land

1. Solid material spills on the land can lead to extensive environmental impacts. Material spills of this nature spread through wind and surface runoff. If not properly contained and secured, this material can travel considerable distances or become incorporated in local water bodies, adversely affecting the water quality and associated habitat. Runoff from the spill area can also contaminate these water sources if not properly collected.
2. Appropriate PPE should be donned before attempting to contain and recover spilled materials. Depending on the material, this may require the use of respiratory protection, goggles or facemask, rubber gloves, boots, and/or disposable or other coveralls.
3. No clean-up actions are to take place until the spilled material is identified, and the correct safe handling procedures are put in place.
4. Environmental Regulatory Authority, local spill co-ops, and/or the manufacturer can be contacted to determine the appropriate containment and removal methods to use for the type of chemical spilled.
5. Extensive dry chemical spills should be covered immediately with secured plastic sheets to reduce the potential for the material to become wind-borne or leach into the soil from rainfall.
6. Dry chemicals can be removed with a shovel or by mechanical means and disposed of in an appropriate manner.

Spills on Land – Recovery and Removal

Sorbents

Sorbents can be used for small spills of oils, fuels, and lubricating oils that have not infiltrated the ground surface, or any other location where free product is floating or ponded.

Shovel and Barrel

Small crude/lubricating oil spills that have soaked into the ground can be dug out with a shovel. If the spill occurs on lease, spread the oil-soaked soil on a designated treatment area and work it into the first 5 cm of clean soil along with some manure and straw or other fibrous material. This can be worked in with a shovel and rake if the amount is small.

Vacuum Truck and Pumps

Hydrocarbons and saltwater can be recovered from containment areas or from standing water using vacuum trucks. The material is then transferred to holding tanks, sumps, or other approved facilities. Alternatively, 400 bbl tanks can be hauled to the site and set near the collection bell holes. Recovered fluids can then be pumped directly from the bellholes.

Earth Moving Equipment

Large earth moving equipment such as graders, scrapers, hoes, and front-end loaders may be utilized to contain and move oil contaminated sediments to a pre-approved storage, treatment, or disposal area. If the amount of oily sediment is small, it can be spread on a designated treatment area with some manure and straw or other fibrous material to bio-degrade the contaminated material.

Recovery Wells

Where spilled hydrocarbon or saltwater has infiltrated subsurface permeable materials and removal of the contaminated material is not desirable, it may be necessary to drill recovery wells around the spill area to the necessary depth, so the fluid can be intercepted and pumped to the surface.

Spills on Water – Containment, Recovery, and Removal

In situations where a substance that may be deleterious to the health and/or safety of humans and/or livestock or irrigated crops has been spilled into a watercourse it is necessary to notify regulators immediately and warn downstream users to take appropriate actions.

General Containment Procedures

1. In stagnant water bodies, floating booms should be deployed in a manner that will utilize winds and currents to help reduce the spreading of the spill.
2. Shorelines should be protected with floating booms, sorbent booms, or sorbent mats before the spill is moved to shore for removal.
3. In slow flowing watercourses (less than 1 km/h), floating booms should be placed downstream to accumulate spilled material. At higher rates of flow, booms should be angled in a manner that will divert floating material to an area of low flow velocity for removal.
4. Do not place booms in areas where the flow rate is greater than 6 km/h as they will be ineffective in containing the spill. If the flow rate is too high, try to locate a more suitable containment location downstream. Refer to an Oil Spill Co-op Contingency manual for more information on this subject. Flow rates can be determined by measuring the time it takes for an object to float a known distance downstream. The use of elongated objects (such as sticks) may produce erroneous results (on the low side), as they tend to align themselves in the direction of the current, which allows water to slip past them.

Floating Spills

1. Materials that float on water such as oil, diesel fuel, or gasoline, if left to spread, may have serious environmental implications. The rate and direction at which such a spill will spread is dependent on wind, currents, and rate of flow. Spills into stagnant water bodies are generally affected by wind currents and can spread to form complex configurations making containment more difficult. Spills into watercourses such as rivers or streams are often more difficult to handle. Materials may be transported considerable distances by the stream flow before they are contained. High rates of flow or large debris being transported by the stream (i.e., ice, logs, and branches) may damage floating booms or render boom deployment ineffective. It is essential that immediate containment and clean-up be initiated for floating spills in order to limit adverse environmental affects and to reduce clean-up costs.
2. Floating debris in the stream course should be removed or contained upstream. This will prevent floating booms that are located downstream from being damaged and reduce the potential for clogging or damage of skimming or vacuum equipment.
3. Accumulated spill material should be removed by vacuum truck, skimmers, trash pump, or suitable absorbents as quickly as possible.

Floating Spills Under Ice

1. Oil spilled under ice will collect in pockets. In stagnant water bodies, oil will concentrate near the spill area. Holes should be drilled into these pockets and the oil removed by suction equipment.
2. Oil spilled under ice that has formed over moving water is best recovered by constructing an ice slot or trench angled to the stream bank. Oil should be removed by suction equipment on a continual basis to prevent build-up and escape.
3. If ice is too thin to support men or equipment, holes can be formed by dropping large inanimate objects using a helicopter (which requires prior approval from Environmental Regulatory Authority).

Insoluble Liquids Denser than Water

1. Materials that are heavier than water and do not dissolve, such as oily sludges or heavy oils, present unique problems when spilled into water bodies, rivers, or streams. These materials tend to flow and accumulate in low spots due to their greater density. Because they do not dissolve, contaminants can mix with bottom sediments and damage these shallow nutrient rich zones. The spread of these types of spills is dependent on such factors as bottom relief, currents, and flow rate. Containment and clean-up of such spills can be difficult, depending on site-specific factors. Speed and effectiveness of containment and clean-up procedures are critical in reducing the negative impacts associated with these types of spills.
2. Oil Spill Co-op Contingency manuals should be referred to for the most appropriate method of containment and clean-up when dealing with a specific type of spill.
3. If the material has entered a water body or watercourse, natural low areas into which the material will flow and accumulate, should be identified.
4. Natural low areas should be pumped free of spilled material. Any contaminated bottom sediments should be transferred by vacuum lines to corresponding holding tanks. Sediments can then be removed to an appropriate disposal or reclamation facility.
5. Dredging low areas to accumulate spilled material in fast flowing watercourses should only be done when determined necessary, and upon proper authorization from Environmental Regulatory Authority.
6. Construction of a dam or dam system downstream, and diversion of upstream flow should be done only when determined necessary, and upon proper authorization from Environmental Regulatory Authority.

Soluble Chemical Spills into a Water Course

1. Chemicals that dissolve in water, such as “caustic” and other process chemicals, can result in serious environmental impacts when spilled into water bodies. Depending on the toxicity and concentration of the substance, local water quality could be severely affected, and downstream users placed at considerable risk. Once incorporated in the aqueous environment, tracing these contaminants can be difficult. Wind, currents, flow rate, and sometimes bottom relief influence the spread of contaminated water. It is imperative that all reasonable effort be made to prevent soluble chemicals from entering water sources, and land-based clean-up operations be initiated immediately. If spilled chemicals do enter a watercourse, a quick and effective response will help to limit the environmental impact.
2. Immediate notification should be given to the appropriate Oil Spill Co-ops, Regulators, and the affected landowners to ensure public safety and an expeditious clean-up operation.
3. Oil Spill Co-op Contingency manuals should be consulted for the most effective method of containment and clean-up method for particular spills.
4. Clean-up of the spilled material should be initiated immediately in order to minimize the area affected and the degree of environmental impact.
5. If chemicals have entered the watercourse, a dam should be constructed downstream from the spill site. If possible, water upstream of the spill should be diverted upon proper authorization from Environmental Regulatory Authority.
6. If damming and diversion are not feasible, then an accepted method for in-situ treatment of the contaminated water should be considered (i.e., activated carbon absorption, precipitation, neutralization, etc.).

Procedures for Obtaining Initial Soil Samples After a Spill

Sample Labelling and Storage

1. Store samples below 4°C and send them to the laboratory within 48 hours of sampling.
2. Clearly label all samples with the:
 - company name
 - well name/location
 - dates
 - sample location
 - unique sample identifier number, and
 - the name of the person who obtained the sample.
3. Store samples for transport in a secure travel container (i.e., a cooler).
4. In summer months pack the cooler with some frozen ice packs or ice to keep the samples below 4°C.
5. Wrap samples kept in glass jars individually in “bubble wrap” prior to packing in the cooler.

Laboratory Details

1. A chain-of-custody (CoC) or laboratory supplied Analysis Request Form should be completed and sent with the samples.
2. Ensure that all of the samples being sent to the lab are documented on the form, and that the proper analyses are requested for each sample.
3. Ensure that the required turnaround time for results is indicated. Normally these forms are in triplicate.
4. Retain one (1) copy for filing and send the other two (2) copies along with the samples.
5. The laboratory should be instructed to sign the CoC form when the samples are received and send one (1) of the copies back to confirm that they received the samples.
6. Keep both copies of the CoC form on file.
7. The laboratory will supply the sample containers, labels, CoC/Analysis Request forms, and the shipping container.

Spill Location

The spill location will likely have the greatest impact on the number and complexity of issues that a response team is faced with. The following are typical examples of how location can affect the spill's impact:

- **Populated versus Unpopulated areas:** Spills in remote areas will likely have less impact on the general public, as opposed to the same incident occurring in a populated area. Remote areas usually have their own unique characteristics that can present challenges to the responsible party (i.e. communications problems, resource availability, equipment access, exposure to wild animals, etc.).
- **Spills in Surface Water versus Land Based Spills:** Spills that migrate into surface water are much more complex to deal with than land-based spills. The issues become more complex when there is a current carrying the product downstream, particularly when there are downstream water users and the stream or river is abundant in fish and wildlife.
- **Land Uses:** It is not uncommon for there to be several land uses associated with a spill incident. The more land uses affected by the spill, the more issues the response team is usually faced with.
- **Spill Site Characteristics:** The soil structure, vegetation types, presence of storm, and sewer drains, topography, and man-made structures at a spill site are just a few of the potential site characteristics that can have an impact on the incident.

Time

The time of day, day of the week and month of the year all have an impact on the issues related to the incident. For example, a spill that occurs in the middle of the night will probably have a delay in the overall response.

Weather Conditions

Weather conditions can help or hinder the conditions at a spill incident. Wind can have major effect on downwind exposures, it can change directions in a matter of seconds and move spill vapours into highly sensitive areas. In some cases, stronger winds can disperse vapours and reduce the flammable range and toxicity of a hydrocarbon plume migrating from the incident site. Strong winds also have the potential to blow debris around the site and cause dead standing timber to fall. In the absence of wind, vapours can pool in low areas in and around the spill site. Wind can also affect the movement of a spilled substance on surface water by increasing or decreasing the spreading rate and pushing the substance in a downwind direction.

Temperature may have an effect on the behavior of a spilled substance and can reduce or increase vaporization rates. In addition, temperature extremes can present health risks to responders such as heat stress, hypothermia and exposure to lightning strikes. Travel time for responders can also be influenced by weather conditions.

Winter conditions present their own unique problems such as product mixed with or under ice and snow, short days, cold temperatures, equipment limitations, etc.

7.14 Sour Gas Release

7.14.1 Critical Sour Wells – Sour Release from a Manned Operation

For critical sour wells, if the EPZ includes a portion of an urban density development or urban centre, there must be a minimum of two mobile air quality monitors: one to monitor the boundary of the urban density development or urban centre and the other to track the plume. The licensee must also:

- Ensure that one unit is in the area during drilling and/or completions, testing, and workover operations in potentially critical sour zones.
- Ensure that the other unit is dispatched if it is evident that well control measures are deteriorating, and that sour gas release is likely to occur.
- Prior to conducting operations in the sour zone, determine where the monitoring equipment is located and what the estimated travel time is to the well site.

For critical sour wells whose EPZ does not include a portion of an urban density development or urban centre and for all noncritical sour wells, the licensee must:

- Dispatch mobile air quality monitoring unit(s) when it is evident that well control measures are deteriorating and that a sour gas release is likely to occur.
- Prior to conducting operations in the sour zone, determine where the monitoring equipment should be located and what the estimated travel time is to the well site.

Air quality monitoring occurs downwind, with priority being directed to the nearest un-evacuated residence or area where people may be present.

The licensee is expected to provide monitored H₂S and SO₂ information on a regular basis throughout a sour gas emergency to the environmental agency, the applicable Regulatory Authority, local health authority, and other local authorities.

7.14.2 Non-Critical Sour Gas Release from an Unmanned Operation

If the licensee is notified of a release by an alarm or by a reported odour, the source of the release must be investigated, and air quality monitoring units sent out upon confirmation of the release location.

Entry Procedures into the EPZ

- Only authorized personnel may enter the response zones.
- Use the "Buddy System" when required.
- Keep in contact with the Incident Commander using two-way radio or mobile telephone.
- Schedule reports every 10 to 15 minutes while in the response zones.
- Wear personal protective equipment (PPE).

- Continuously monitor the concentration of combustible gas (LEL) in the area.

7.14.3 *Sour Gas Release Site Safety*

- Communicate with all workers the potential presence of H₂S, SO₂ and LEL levels.
- Immediately initiate atmospheric monitoring of H₂S, SO₂ and LEL levels.
- Designate a safe muster location based on the extent of the Sour Gas release.
- Initiate immediate evacuation of all non-essential personnel.
- Identify areas of the site with confirmed or potential H₂S, SO₂ and LEL levels.
- Complete a site roll call to account for the safe location of all personnel that were on site prior to the event occurrence.
- Identify any unaccounted-for personnel.
- Attempt to remove or control all ignition sources, where ignition would threaten safety of workers.
- Perform search and rescue for site personnel unaccounted for or overcome by H₂S and SO₂.
- Continue to provide atmospheric monitoring of H₂S, SO₂ and LEL levels to ensure the safety of the Muster Location and emergency responder staging position.

Safety of Response Operations

- Ensure personnel that assist with release control operate only within their specific:
 - Levels of training.
 - Capability.
 - Experience.
- Personnel remaining in proximity to H₂S and SO₂ exposures shall be provided with and shall wear the appropriate PPE and SCBA appropriate to the exposure hazard.
- Ensure that any personnel utilizing SCBA have been properly trained and fitted.
- Monitor and provide control of the operating time of site personnel working in SCBA.
- Establish a decontamination station prior to assigning personnel to enter areas in proximity to H₂S and SO₂, for the safe and timely decontamination of any exposed personnel.

Action Plan Sour Gas Release

- Attempt to stop the release of Sour Gas, when safe to do so.
- Notify local emergency response agencies.
- Notify potentially exposed residential or public areas.
- Determine and implement public protection actions.
- Maintain air monitoring for H₂S and SO₂.
- Activate the Site Command and CEOC Command for support.
- Assist emergency response agencies in organizing area evacuations and access restrictions.

Request Emergency Response Agencies

- Call 911.
 - Request Fire Department, Emergency Medical Responders, and Police.
 - In the event of potential exposure to a sour gas release off-site
- Request that the local Emergency Management Representative and local police agency respond.
- Maintain air monitoring for levels of H₂S and SO₂.
- Designate a safe staging position for responding resources.

Brief Emergency Responders

- Provide emergency responders with an SDS for H₂S and SO₂.
- Brief emergency responders on:
 - Event timeline.
 - Nature of the release; dynamic - static.
 - Hazards of the release; flammable, corrosive, toxic, asphyxia.
 - Status of personnel accountability; search and rescue profile.
 - Other uncontrolled facility hazards.
 - Status of the release control operation.

- Status of other operating personnel within the facility.
- Identify the number of injured/exposed people due to any inhalation hazard.
- Identify the uncontrolled sources of ignition.
- Identify any confined spaces.
- Identify any low-lying areas where H₂S and SO₂ may pool.

7.15 Sweet Gas (Hydrocarbon) Release

The effectiveness of the following guidelines depends on the judgment exercised by all personnel. To extinguish hydrocarbon fires and prevent further explosions, it is necessary to do at least one of the following:

1. **Remove fuel** by isolating the section of equipment on fire and pumping out or depressurizing the flammable material.
2. **Remove oxygen** by the use of steam, chemicals, foam, dry powder, or CO₂ extinguishers. If the fire is small, the flames can be smothered with a fire blanket, new tarpaulin, or sand.
3. **Cool fuel** so that it no longer produces vapors using water where possible (as a fog) to extinguish fires or as a coolant for equipment, tanks, support columns, etc. or use to provide a protective shield while the fire is being extinguished by foam, chemicals, or power extinguishers.

Response Actions:

- Understand the type of product and its immediate hazards.
- Establish an evacuation route and muster point for workers at the site.
- Shut in all known fuel sources. Do not extinguish a leaking gas flame unless the leak can be stopped.
- Shut off high voltage power supplies to equipment in fire-affected area.
- Shut off fuel to heaters near to or downwind of the fire.
- Observe surrounding area for other possible re-ignition sources and if safe to do so take appropriate steps to eliminate these hazards.
- Dissipate static electrical charges on bodies of all personnel in area. Grounding may be accomplished by holding onto a metal structure for ten seconds with bare hands.
- Approach the site from an upwind or crosswind direction.
- Ensure an appropriate on-site and off-site air monitoring strategy is employed.
- Monitor the area for LEL.
- Monitor local weather conditions. Weather conditions such as temperature inversions, fog and wind may affect plume dispersions.
- Do not use water jet. For a small fire, use dry chemical, CO₂, water spray, or foam. For a large fire, use water spray, fog, or foam. Beware of electrical hazards.
- Move containing vessels from the fire area if this can be done without risk.
- Cool containing vessels with flooding quantities of water until long after fire is out.
- Keep unauthorized personnel away.

7.15.1 Flammability Limits

Monitored Flammability Limits (% of LFL)	Comments and Typical Actions
10% of the LFL (LFL/10)	This concentration represents a level at which industry response personnel should leave the area or don fire protective clothing if continuing to work in this environment or if approaching the source of a release.
50% of the LFL (LFL/2)	A concentration level at which ignition and flame propagation through a dispersing plume may be possible due to the non-homogenous nature of dispersion in the atmosphere (i.e., concentration fluctuations). A meteorologically weighted distance to this criterion (as calculated using quantitative hazard analysis methods) is often used as the basis for establishing emergency planning zones for flammable substances. If measured by air monitoring, this concentration represents a level at which public protection measures such as removal of ignition sources, shelter-in-place or evacuation may be warranted.
100% of the LFL (LFL)	A concentration level at which (in the presence of an ignition source) ignition and flame propagation through the dispersing plume is highly probable. Extreme caution should be exercised, and emergency response personnel should withdraw from the area.

Adapted from Best Management Practices, Emergency Air Monitoring, Canadian Association of Petroleum Producers, March 2014

7.16 Hydrocarbon Exposure

Exposure to flame (delayed ignition of a hydrocarbon gas release). Direct exposure to flame occurs when ignition of a flammable gas cloud in the environment is delayed. If ignited, a flame front will move from the point of ignition, through the gas, to the source.

For planning purposes, the flammable region of the plume is assessed by estimating the concentration of fuel in air as the gas is transported and dispersed from the release site. The lower flammable limit (LFL) is the lowest concentration at which the fuel will support combustion in the presence of an ignition source. While hydrocarbon gases cannot burn below the LFL, the distance to one half of the LFL (LFL/2) is used as a conservative basis for establishing the boundaries of the flammable region. For emergency response purposes, responders will use monitors to determine where a flammable gas exists.

Direct exposure to flame can result in third degree burns or death. If you detect a hydrocarbon release, extinguish and reduce all ignition sources and, if possible, move away from the area on foot in a cross-wind direction away from the source. If you cannot leave the area on foot or are uncertain about the source of a release or the wind direction, please shelter indoors.

7.16.1 Exposure to Heat Radiation (ignited hydrocarbon release)

Exposure to thermal radiation can result from a:

- Pool fire or refers to the burning of liquid hydrocarbon at the surface of a liquid hydrocarbon pool (e.g. burning of an oil pool).
- Jet fire: refers to the burning of liquid or gas at the point of the release into the atmosphere (e.g. the flame on the tip of a butane torch).

A number of criteria are used to evaluate the effects to people of heat exposure. These include:

- Thermal Radiation: a measure of the instantaneous level of heat radiation received at a location near a release.
- Thermal Load: a measure of the cumulative heat received at a location near a release and is a better measure of the overall impact to people.

These effects of heat exposure are summarized for these criteria in the tables below.

Thermal Radiation

Radiation Intensity (kW/m ²)	Damage to Equipment	Exposure to People
4	Sufficient to cause pain to personnel if unable to reach cover within 20 seconds; blistering of the skin (second degree burns); 0% lethality.	
12.5	Minimum energy required for piloted ignition of wood; melting of plastic tubing.	1% lethality in 1 minute. First-degree burns in 10 seconds.
25	Minimum energy required to ignite wood at indefinitely long exposures (non-piloted).	1% lethality in 30 seconds. Significant injury in 10 seconds.
37.5	Sufficient to cause damage to process equipment.	100% lethality in 1 minute. 1 % lethality in 10 seconds.

World Bank (1985) in Guidelines for Chemical Process Quantitative Risk Analysis, Center for Chemical Process Safety of the American Institute of Chemical Engineers, 1989.

Thermal Load

Harm Caused	Thermal Dose Units (TDU) (kW/m ²) ^{4/3} s
Pain	86 to 103
First Degree Burns	80 to 130
Second Degree Burns	240 to 350
Third Degree Burns	870 to 2600

Health & Safety Laboratory, 2004
For the purposes of establishing HPZs, the maximum distance to a thermal load of 342 (kW/m²)^{4/3} s is applied.

7.17 Liquids Release – Site/Facility

7.17.1 Liquid Release Site Safety

- Activate the site evacuation alarm and establish safety zones to protect workers, residents and public. Reference EPZ map or utilize Emergency Response Guidebook for zoning guidance.
- Where the spill/release is flammable, eliminate any sources of ignition and monitor for Lower Explosive Limits.
- Reference SDS for released material’s properties (located in the site office, drilling floor, etc.):
 - Exposures considerations.
 - Handling precautions.
 - Personal Protective Equipment.
 - Clean-up measures.
- Assess the specific hazards associated with exposure and response to the spill.
- Ensure that all site personnel are accounted for.
- Ensure all workers in proximity to the spill, are monitored to ensure their personal safety.
- Countermeasures must only be initiated where hazardous material exposure can be controlled within training levels of workers.

7.17.2 Action Plan for Liquids Release

- Where available consult the site-specific or field area section for an overview of spill potentials and environmental receptors including waterbodies and streams.
- Contain release to the site recovering as much spilled material as possible.
- Protect surface waterbodies, groundwater and other sensitive environmental receptors in the area.
- Notify Company management and notify local emergency response agencies.
- Rapid mobilization of response contractors and any additional technical support.

- Establish decontamination procedures prior to commencing recovery efforts.

Evacuate and Restrict Access

- Evacuate personnel from the facility when required by the scale of the spill.
- Request through 911 roadblocks and or evacuation of residents where indicated.
- Provide facility security at the access points to the facility to:
 - Restrict access to areas in proximity to the spill.
 - Maintain accountability of the personnel on site.
- Initiate the notification and access control to exposed or threatened public areas off-site.
- Coordinate roadblocks.

Identify the Released Material

- Identify the spilled product:
 - Chemical Name.
 - Common name.
 - Class.
 - Type.
 - UN/DOT Number.
- Reference the product's SDS identifying:
 - The flammability of the spilled product.
 - PPE requirements for proximal exposures and handling of the spilled product.
 - Released materials reaction with organic materials.
- Immediately report the release event to the line supervisor, providing all known information available.

Identify the Release Parameters

- Identify the source of the release.
- Identify and remove any known potential ignition sources for the spilled product within the Planning Zones.
- Initiate monitoring of any flammable or combustible material:
 - Identify and monitor elevated LEL areas.
- Identify:
 - The likely spill exposure area.
 - Velocity and volume of the release.
 - Potential to erode or overcome site containment features.
 - The potential worst-case scenarios.
- Consider discontinuing operations for larger dynamic release events.

Identify the Release Exposures

- Reference available site documents.
- Identify the release exposure to the Spill Retention Basins (SRBs).
- Identify the release exposure to Environmental receptors (e.g. waterbodies, streams, ground areas with high permeability, marshes, etc.).
- Identify any public or resident exposures.

Identify the External Resources Required

- Responding agencies.
- Technical personnel.
- Manpower.
- Equipment.
- Specialized materials.

Report Incident Information to the Incident Command Post

- Event timeline.
- Material released.
- Hazards and exposures generated from the released material.
- Volume of release.
- Volume-rate of release.
- Likely total volume of release.
- Worst case release volume.
- Off-site areas of release sensitivity.
- Current release control actions.
- Planned release control actions.
- External resource support required.

Initial Countermeasures

- All response personnel shall wear appropriate PPE.
- Provide a decontamination station for responders and initial containment personnel.
- Stop the flow of product at the source if safe to do so:
 - Close Isolation Valves.
 - Shutdown Transfer Pumps.
 - Transfer materials from leaking tanks into available and compatible undamaged storage tanks, vacuum trucks or lined secondary containment areas.
- Attempt control of the release by:
 - Confining the released materials to on-site areas.
 - Utilize absorbent booms and pads to contain and clean-up smaller release events.
 - Directing the release away from and limiting the negative exposure or spill accumulation in or around critical site facilities and components.
- Utilize the Spill Retention Basins (SRBs) as release control points:
 - Immediately plug off/cap the discharge pipes.
 - Block off drainage ditches, culverts and discharge pipes with sandbags, earthen dikes, and other available materials.
- Where containment is not possible, attempt to divert the release in a direction that may:
 - Allow for containment.
 - Use natural containment (topography).
 - Provide an outfall away from waterways.
 - Limit exposure of sensitive areas.
 - Limit public exposure.
- Adequately monitor Facilities for:
 - Leaks, pressure build-up, and gas generation.
 - Valve, pipe and equipment ruptures.
- Where a material release has entered waterway and cannot be contained, attempt to create control points:
 - In the event that the released material is lighter than water, create a dam with an underflow water passage to allow clean water flow while retaining and controlling the released material at the dam location.
 - In the event that the released material is heavier than water, create a dam with overflow water passage past the dam to allow clean water flow while retaining and controlling the released material at the dam location.

Management of Recovery Operations

- Track and document the areas outside the fence line, with regard to:
 - Release volume.
 - Proximity/exposure monitoring.
 - Control actions – time-based record.
 - Clean-up actions – time-based record.
- Initiate soil sampling and regulatory communication about remediation as maybe required.
- Recover surface fluids and contaminated soil.
- Fence-off release areas to protect people and wildlife until reclamation is complete.
- Contaminated material must be placed in appropriate impermeable storage (steel tank, lined containment area, etc.), sampled and disposed of at an approved licensed disposal facility.
- Plan adequate storage and disposal of any recovered/ contaminated product.
- Follow approved Transportation of Dangerous Goods (TDG) regulations when shipping recovered /contaminated materials.

7.18 Well Kick Incident

Possible warning signs of a well kick.

- Change in flow rate from well.
- Change in the rate of drilling.
- Change in pump pressure.
- Rapid change in mud properties.
- Fluctuations in weight indicator readings and/or erratic torque.

7.18.1 Well Kick Site Safety

- Well operations shall be monitored for the warning signs of a well kick.
- Never allow a crew member to look down the hole during a flow check.

Action Plan for Well Kick Incident

- Drill plan to include realistic kick tolerance(s); rig drills to ensure tolerances can be detected and shut-in.
- Once the well is shut-in the choke should remain closed.
- If the pressure exceeds maximum allowable, prepare for possible remedial actions.

Flow Check

- Call an alert.
- Pick up off bottom to clear the Kelly and ensure there are no tool joints across the rams.
- Stop the pump.
- Divert the flow line to the trip tank.
- Read and record the trip tank volume.
- Record the flow check and its results in the tour report.

Shut-In Procedures

- Call an alert.
- Pick up off bottom to clear the Kelly and ensure there are no tool joints across the rams.
- Stop the pump.
- Shut-in process is to open the hydraulic valve at the BOP/ HCR (hydraulically operated gate valve) and close a pipe ram.
- Let the pressure stabilize for 5 – 15 minutes.
- Read and record SIDPP.
- Read and record SICP.
- Read and record any gain in the trip tank.
- Prepare to kill the well.

Post-Incident Inspection/Function Testing

- Once a well kick has been detected and resolved a post kick inspection/integrity check of all operating equipment is to be completed.

7.19 Blow Out Incident**7.19.1 Blow Out Incident Safety**

Immediate Site Safety Procedures:

- Initiate site alarm/evacuation alarm/control ignition sources.
- Complete a headcount of all personnel on location.
- Report any missing personnel to the On-Site Group Supervisor.
- Where possible, determine who is missing and the last known location or work area.
- Coordinate rescue and treatment of workers exposed as required.
- If gas release is sour (or other toxic contaminant), ensure Public Protection Group Supervisor role is activated including air monitoring and roadblocks.
- Develop and communicate planning zones based on release rate and escalation potentials.
Consider:
 - Well – time duration of liquid returns (if any).
 - Pipeline – time duration of pipeline isolation and de-pressuring.
 - Environmental conditions – wind speed/direction, nearby structures, forested, etc.
- Develop and communicate PPE and personal gas detector requirements.
- Avoid personal exposure to pressurized gas jets and all flammable areas.
- Identify a new and safe post evacuation mustering location.

7.19.2 Action Plan for Blowout Incident

- Isolate the leak/release and reduce back flow potential.
- Isolate pipeline to reduce back flow potential.
- Initiate air monitoring, roadblocks, resident notifications and prepare for media/public concern.
- Coordinate spill response and clean-up plan.

Request Emergency Response Agencies

- Call 911.
 - Request fire department, emergency medical responders and police.
 - Designate a safe staging position for responding resources.
- In the event of potential exposure to the public request that the local Emergency Management Representative and local police agency respond.
- Maintain air monitoring for levels Natural Gas.

Brief Emergency Responders

- Provide external emergency responders with an SDS.
- Brief emergency responders on the:
 - Event timeline.
 - Status of personnel accountability; search and rescue profile.
 - Status of the release control operations.
 - Nature of the release: dynamic - static.
 - Other uncontrolled facility hazards.
 - Status of other operating personnel within the facility.
 - Hazards of the release: e.g. flammable, corrosive, toxic, asphyxia.
- Identify the number of injured/exposed people due to any inhalation hazard.
- Identify the uncontrolled sources of ignition.
- Identify any confined spaces where lighter than air gases and/or heavier than air gases from liquids could accumulate.

Implement Release Control Actions

- Identify the release point and point(s) of control.
- Identify any buildings, facilities or residences near the release point and point(s) of control.
 - Gas detected inside a building – evacuate all occupants to the muster point or reception centre. Shut off all ignition sources if safe to do so.
 - Gas detected near a building – determine if occupants should shelter in place or evacuate to the reception centre. Shut off all ignition sources if safe to do so.
 - If the gas test readings indicate rising LEL, evacuate all occupants to the reception centre.

Small scale hydrocarbon releases from the wellhead/pipeline/facility or equipment.

- Approach from upwind of release point.
- Isolate leak by closing isolation valve(s).
- Isolate leak by plugging/patching/stabbing valve or other approved method.

Large scale hydrocarbon releases that remain on-site (in addition to above items):

- Request external manpower and equipment.
- Initiate LEL monitoring.
- Shut-in to reduce formation pressure.
- Consider tying in tanks or flare line to control/direct the release.
- Develop waste clean-up and storage plan.

Large scale hydrocarbon releases from the well head that remains on the lease site.

- Request external manpower and equipment.
- Identify injection wells in same zone.
- Shut-in to reduce formation pressure.
- Consider tying in tanks or flare line to control/direct the release.
- Develop waste clean-up and storage plan.

Large scale hydrocarbon off site releases, or releases not controlled by site personnel or equipment

(in addition to above items):

- Request external manpower and equipment.
- Initiate down-wind LEL/H₂S/SO₂ monitoring, roadblocks and resident notifications as required.
- Secure the facility area.
- Determine plume ignition plan if required.
- Develop contingency plan.
- Consider tying in tanks or flare line to control/direct the release.

Implement Fire Control Actions where ignition has occurred

- If the fire is located near or directly involving a pipeline facility isolate and de-pressure the line as needed.
- If the fire is located near pressurized vessels, evacuate and prepare for a potential BLEVE.
- Before extinguishing a pressurized gas fire, ensure readiness plan is in place to address the gas plume and potential migration.

Post-Incident Actions - Securement of affected equipment

- Consider keeping equipment operators and supervisors to assist as required.
- Contact Hierarchy 1 Incident Command Post and request post-incident instructions including:
 - Internal accident Investigation.
 - Equipment impoundment/security.
 - Critical Incident Stress Debriefing.
 - Government Investigations.
 - Site Security.

7.20 General Fire Response

Extinguish fires and protect property impacted from fire without putting responders at risk. Control or eliminate product release and extinguish ignition sources to prevent a fire or explosion.

- Shut-in source (if safe to do so).
- Ensure personal safety.
- Call emergency services as required - 911 - Police, Fire, or Ambulance.
- Conduct a risk assessment.
- Determine the level of emergency.
- If practical, implement a fire attack strategy to extinguish fire or cool equipment/facilities from the fire.
- Order resources such as water tanker, local fire department equipment and/or fire response contractor to assist in the response.
- Implement off site monitoring for LEL, hazardous gas and/or smoke particulates.
- If the public is at risk from smoke or hazardous gas, implement a public communication and protection plan.
- Make the appropriate notifications.
- If safe to do so, remove ignitable products from the fire scene.
- Consider off-site fire hazard conditions (dry vegetation, etc.) and implement a response plan to prevent the spread of the fire.
- Maintain ICS 214 – Activity Log.
- Restrict access to site. Preserve the site so that a follow-up investigation can be conducted.
- Participate in debriefing and share learning.

7.20.1 Facility Fire Safety

- Ensure effective evacuation and identification of trapped and/or missing workers.
- Establish response zones and PPE requirements.

The conducting of rescue operations, product isolation or fire suppression operations during facility fire events are restricted to:

- Activities that are consistent with the experience and reasonable capability of the utilized personnel.
- Activities within the level of training and PPE utilized by the personnel involved.
- Activities that are deemed consistent and appropriate for the scale of the fire event and the conditions present.

All operations must be evaluated relative to their risk potential vs. the benefit to be gained:

- The gain that may be achieved.
- Versus the potential exposure to risk that may or will be present.

Pressurized fuel fires that contain heavier than air components (typically all liquids) pose a significant risk to personnel in the event that the fire is extinguished.

Lighter than air fuels (typically natural gas) pose a significant risk if extinguished inside a closed space e.g. compressor building.

In all cases, personnel shall not be committed to operations or locations that may expose them to any of the following hazardous conditions (this includes the direct positioning, the proximity positioning or the positioning of personnel in locations that may create an exposure to incident escalation, fire growth or event escalation):

- Direct fire contact.
- Heat exposure.
- Smoke and products of combustion.
- Areas of diminished oxygen content.
- Confining or restrictive spaces.
- Locations in proximity to buildings or structures that have been weakened by fire exposure, heat exposure or significant water application.

7.20.2 Action Plan for Facility Fires

- Conduct an assessment to identify all the hazards, conditions, and facets of the event.
- Call for additional internal and external resources as required.
- Develop the Incident Action Plan.
- Initiate remote isolation where facility/local isolation is not possible.
- Close Site Retention Basin outlet valve where applicable.
- Do not direct fire suppression operations where run-off may cause environmental damage.
- Initiate Unified Command with emergency responders; ensure safety guidance is reviewed and adhered to before commencing response operations.
- Execute Incident Action plan.

Conduct an Extensive Assessment

Gather event information to identify all the hazards, conditions and facets of the event, including but not limited to:

- Location of the fire and the areas involved in fire.
- Location and accountability of all personnel – rescue requirement.
- Type of fuel involved.
- Source of the fuel.
- Wind direction.

- Critical escalation potentials – BLEVE potential, chemical fire, catastrophic failure, high valve assets.
- Fire growth exposures.

Call for additional resources as required

Inventory personnel, fire suppressant resources (fire extinguishers, water supplies) and fire suppression appliances.

- Identify the resources required and not present on scene.
- Request the resources required.

Establish Response Zones

Establish Response Zones and the PPE requirements per zone.

- No Entry Zone - perimeter.
- Emergency Planning Zone - perimeter and PPE requirement.

Develop the Incident Action Plan

Develop the Incident Action Plan consistent with appropriate event management priorities:

- Rescue or protection of life.
- Protection of critical escalation potentials.
- Protection of uninvolved structures, machinery or assets.
- Confinement of fire to currently involved locations.
- Extinguishment of fire.

The Incident Action Plan once developed shall identify:

- Incident objectives.
- Strategies.
- Safety.
- Weather.
- Resource allocation.
- Critical support requirements.

Brief Personnel

Brief site personnel to identify the parameters of the incident and to set initial expectations with regard to safety and assignments. Identify:

- Assessment information.
- Response Zones and PPE requirements.
- Incident Action Plan.
- Provide personnel assignments.

Ensure Critical Command Issues are Established

Ensure any fire event activities conducted must be done so with the following critical emergency event command issues fully established and in place prior to initiating any proximity operations:

- An organized ICS deployment structure.
- An effective communication system.
- An established personnel accountability system.
- A risk versus benefit-based Incident Action Plan.
- Identified strategies, tactics and operational applications to support the Incident Action Plan.
- The presence and full availability of all required resources.
- A comprehensive air management system to control SCBA operations.
- Resource allocation providing a 2-man team appropriately equipped and supported to protect, maintain and ensure the safe egress route of every 2-man proximity team.

Execute the Incident Action Plan

- Conduct, direct, monitor and adjust the application of the Incident Action Plan.
- Re-evaluate the appropriateness of the Incident Action Plan and its strategies, tactics and operational applications.
- Ensure adherence to appropriate event management priorities.
- Re-evaluate the resource requirements of the event.
- Ensure the completion and adherence to the critical command issues.

7.21 High Vapour Pressure (HVP) Release**7.21.1 HVP Product Release Monitoring**

Monitoring may occur downwind or upwind depending on how the plume is tracking, with priority being directed to the nearest un-evacuated residence or areas where people may be present.

The licensee is expected to provide monitored HVP product LEL information on a regular basis throughout the emergency to the environmental agency, the Regulatory Authority, local health authority, and other local authorities and on request to the public.

Air Quality Monitoring equipment will be used to:

- Track the plume.
- Determine if ignition concentration criteria are met.
- Determine whether evacuation and/or sheltering concentration criteria have been met, particularly beyond the EPZ.
- Assist in determining when the emergency status can be downgraded.
- Determine roadblock locations.
- Determine concentrations in areas being evacuated to ensure that evacuation is safe.

The type of air quality monitoring units and the number of monitors required are based on site specific information, including:

- Access and egress points.
- Population density and proximity to urban density developments.
- Local conditions.

NorthRiver will dispatch mobile air quality monitoring equipment from contract service companies located in the area to monitor and record air quality.

Ambient air quality data from the monitoring unit(s) will be communicated by cell phone or mobile radio to the On-Site Command Post.

If a sour gas release has been ignited, the permit holder should continue to monitor response zones for H₂S from incomplete combustion as well as SO₂.

7.21.2 Ignition Considerations

Company and Contract Operators should be familiar with the guidelines for igniting a high vapour pressure release. ERP procedures should be reviewed as part of a pre-job safety meeting whenever work begins on or near HVP pipelines or wells.

The following items must be considered:

- **Immediate Ignition:** If Company personnel are on-site when a release occurs, and a qualified company representative is present they may ignite the release.
- **Delayed Ignition:** If Company personnel are not on-site when a product release occurs a vapour plume may form.

The following items should be considered before ignition:

- Has the perimeter of the EPZ been established?
- Have all persons been evacuated from the area?
- Will ignition worsen the situation by endangering the environment, public, private property, equipment or facilities?
- Has the wind direction been established and is it being continually monitored?

Following an initial assessment, the Incident Commander must decide if plume ignition is a viable option. Once ignited, the dangers inherent with the vapour cloud are eliminated. The Response Team should prepare for potential problems as a result of ignition by placing fire fighters on standby.

If trees, buildings, or any obstructions are in the product plume, these items may ignite explosively. All people should be moved to a safe distance.

Controlled ignition eliminates the potential of vapours finding an unsuspected ignition source. Typical issues that may affect high vapour pressure releases include:

- Time of release (day, night, weekend).
- Injuries requiring medical attention.
- Identification of the release boundaries.
- Estimate product volume and plume size.
- Wind direction and speed.
- Topography.
- Vegetation.
- Road access.

7.21.3 Guideline for Igniting HVP Plume

The following steps are a guideline to igniting a high vapour pressure plume:

1. Conduct a complete assessment that includes the identification of the plume perimeter.
2. Take steps to prevent injury including evacuation (if necessary) and the protection of the response team.
3. Approach wearing flame resistant clothing, eye protection, hard hat and a flammable gas detector.
4. Approach the plume from up-wind and slightly cross wind (as there is a greater area of the plume to hit with a flare).

Refer to Figure Below:

- Stop 200 metres (minimum) from the suspected perimeter of the vapour plume.
- Remember that the flammable perimeter may extend beyond the visible portion of the plume.
- Remember that the heat affected zone extends beyond the flammable perimeter.
- Test for flammable vapour in the atmosphere using a flammable gas detector.
- Use the manufacturer's procedures for loading the flare shell and always point the pistol or launching device at the ground during loading (and until fired).
- Ensure that you begin outside the defined hazardous area.
- Attempt to hit the perimeter of the vapour cloud where the air to fuel mixture is correct for ignition (near outer edge and ground level).
- If no ignition takes place it can be assumed that the flare did not pass through the flammable vapour range of the plume.
- Make the appropriate trajectory adjustments and shoot again. Proceed in this manner until ignition is accomplished.
- Upon ignition, proceed with preventative steps to control unwanted fire.
- Do not extinguish the burning vapour plume.

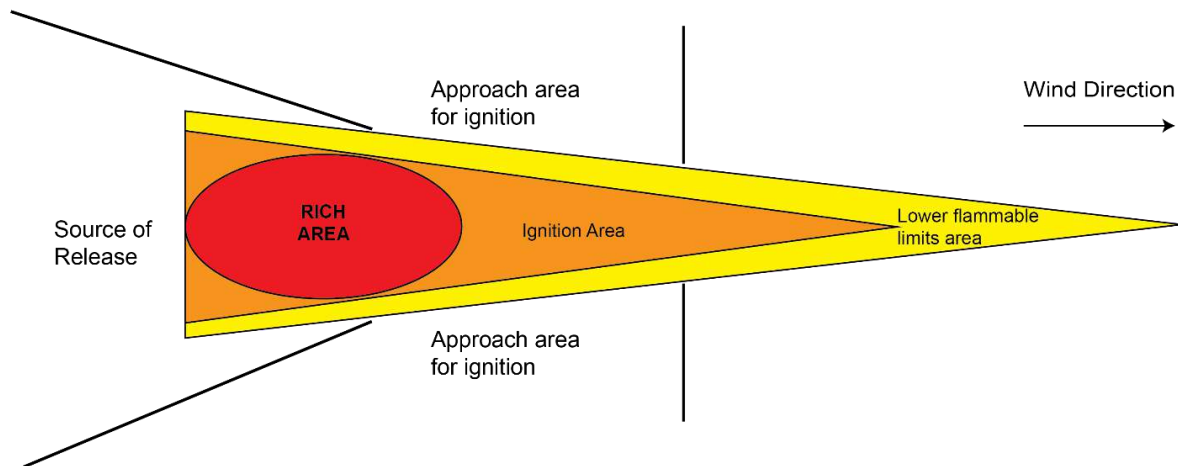

7.22 Pressurized Fuel Fire

The Company strategy is to isolate the fuel, remotely if practical, while protecting exposures (compressor buildings, forests, etc.) and controlling any damage to the environment.

Where local/direct isolation is to be undertaken, the appropriate safety requirements are to be met e.g. responders trained in pressurized fuel firefighting tactics.

- Pressure fires must not be extinguished unless immediate isolation is assured (typically with a dry chemical extinguisher), as the resulting gas release will endanger personnel.
- Pressurized fuel fires with liquids may involve a ground fire, potentially with burning liquids raining down. Suppressing these fires with water streams could result in run-off that causes environmental damage.
- Where the fuel is sour, some portion of the SO₂ emitted from the fire can be knocked down by the use of water sprays. The benefit must be weighed against the potential environmental damage of entrained SO₂ in the run-off i.e. run-off may require collection and neutralization.
- Typically, pressure fires can be quenched with water streams without fear of extinguishment. As depressurization occurs, caution needs to be exercised that the fire is not extinguished, which would lead to flammable vapours being released into the incident area.

7.23 Propane or LPG Tank Fire

The Company strategy is to evacuate as far as possible, as soon as possible; up to the distances recommended below. Many factors affect the failure time of a propane tank and as such are outside the expertise of non-professional responders. Site personnel are to assume a catastrophic tank failure is imminent (e.g. > 5 minutes) regardless of the tank size.

Evacuation distances are based on predicted fire ball and fragmentation areas as expressed by the radius of the fire ball and based on size of the propane tank.

- Recommended evacuation for a propane tanker truck is 1.6 km (1 mile) in all directions.
- Recommended evacuation for a small propane tanker truck is 1,000 m (2/3 mile) in all directions.
- Recommended evacuation for a 500-lb tank is 350 m or 1,200 feet in all directions.
- Recommended evacuation for a 100-lb Tank is 200 m or 650 feet in all directions.
- Recommended Evacuation for a 20-lb Tank is 150 m or 500 feet in all directions.

7.23.1 Boiling Liquid Expanding Vapour Explosion (BLEVE)

A BLEVE occurs when a sealed container of liquefied gas (e.g. propane tank) is accidentally exposed to and enveloped by fire. The internal pressure of the containment vessel rapidly rises. At the same time, the container wall temperature rises, and the wall strength deteriorates. Even though a pressure relief valve may be operating, the stress applied by the increased pressure exceeds the strength of the containment wall.

The container eventually ruptures, and extremely heated liquid is released, expands and vaporizes in seconds resulting in catastrophic damage, as well as the spread of ignited vapours. The ruptured vessel or tank could propel dangerous shrapnel significant distances.

It is important that vessels or tanks are kept cool and the external fires extinguished quickly with water sprays or natural fluoroprotein-based foams.

Propane is naturally in the gaseous phase with a boiling point of -42° C (-44° F). One gallon of liquid propane will expand to 270 gallons of propane gas.

- Isolate spill or leak area immediately.
- Stay upwind, and out of low areas.
- Eliminate all ignition sources.
- All equipment used when handling the product must be grounded.
- Do not walk through spilled material.
- Keep unauthorized personnel away.
- If required, wear positive pressure self-contained breathing apparatus.
- Do not extinguish a leaking gas fire unless leak can be stopped.

7.23.2 *How big is the fireball from a Propane or LPG BLEVE?*

If the propane or LPG release is ignited immediately then a fireball will result. The size of the fireball depends on the mass of the tank contents at the time the tank fails. The shape of the fireball depends on how the tank fails and on the lading temperature. LPGs include the following flammable gases: Butane UN1011, Butylene UN1012, Isobutylene UN1055, Propylene UN1077, Isobutane UN1969 and Propane UN1978.

If we consider a spherical fireball, then an approximate equation for the fireball maximum radius is:

$$R_{\text{fireball}} = 3m^{1/3}$$

where,

R_{fireball} = radius of fireball in metres

m = mass of propane in kg

However, keep in mind that fireballs are not always spherical. In some cases, when the tank fails a large ground fire can result that has a radius larger than that predicted above. Don't assume if you are just beyond the predicted fireball radius that you will be outside of the fire envelope

Fireball sizes and durations for a range of tank sizes

WARNING The data given are approximate and should only be used with extreme caution. These times can vary from situation to situation. LPG tanks have been known to BLEVE within minutes. Therefore, never risk life based on these times.																			
BLEVE (USE WITH CAUTION)																			
Capacity		Diameter		Length		Propane Mass		Minimum time to failure for severe	Approx. time to empty for engulfing fire	Fireball radius	Emergency response distance	Minimum evacuation distance	Preferred evacuation distance	Cooling water flowrate					
Litres	(Gallons)	Meters	(Feet)	Meters	(Feet)	Kilograms	(Pounds)	Minutes	Minutes	Meters	(Feet)	Meters	(Feet)	Meters	(Feet)	Litres/min	US gal/min		
100	(26.4)	0.3	(1)	1.5	(4.9)	40	(88)	4	8	10	(33)	90	(295)	154	(505)	307	(1007)	97	26
400	(106)	0.61	(2)	1.5	(4.9)	160	(353)	4	12	16	(53)	90	(295)	244	(801)	488	(1601)	195	51
2000	(528)	0.96	(3.2)	3	(9.8)	800	(1764)	5	18	28	(92)	111	(364)	417	(1368)	834	(2736)	435	115
4000	(1057)	1	(3.3)	4.9	(16.1)	1600	(3527)	5	20	35	(115)	140	(459)	525	(1722)	1050	(3445)	615	163
8000	(2113)	1.25	(4.1)	6.5	(21.3)	3200	(7055)	6	22	44	(144)	176	(577)	661	(2169)	1323	(4341)	870	230
22000	(5812)	2.1	(6.9)	6.7	(22)	8800	(19400)	7	28	62	(203)	247	(810)	926	(3038)	1852	(6076)	1443	381
42000	(11095)	2.1	(6.9)	11.8	(38.7)	16800	(37037)	7	32	77	(253)	306	(1004)	1149	(3770)	2200	(7218)	1994	527
82000	(21662)	2.75	(9)	13.7	(45)	32800	(72310)	8	40	96	(315)	383	(1257)	1435	(4708)	2200	(7218)	2786	736
140000	(36984)	3.3	(10.8)	17.2	(56.4)	56000	(123457)	9	45	114	(374)	457	(1499)	1715	(5627)	2200	(7218)	3640	962

Emergency Response Guidebook

U.S. Department of Transportation, Pipeline and Hazardous Materials Safety Administration, Transport Canada, Secretariat of Transport and Communications, 2024

Safe Standoff Distance

Liquefied Petroleum Gas (LPG – Butane or Propane)	Threat Description	LPG Mass/Volume ¹		Fireball Diameter ²		Safe Distance ³	
	Small LPG Tank	20 lbs/ 5 US gal	9 kg/19 L	40 ft	12 m	160 ft	48 m
	Large LPG Tank	100 lbs/ 25 US gal	45 kg/95 L	69 ft	21 m	276 ft	84 m
	Commercial/ Residential LPG Tank	2,000 lbs/ 500 US gal	907 kg/1 893 L	184 ft	56 m	736 ft	224 m
	Small LPG Truck	8,000 lbs/ 2,000 US gal	3 630 kg/7 570 L	292 ft	89 m	1,168 ft	356 m
	Semi tanker LPG	40,000 lbs/ 10,000 US gal	18 144 kg/37 850 L	499 ft	152 m	1,996 ft	608 m

¹ Based on the maximum amount of material that could reasonably fit into a container or

² Assuming efficient mixing of the flammable gas with ambient air.

³ Determined by U.S. firefighting practices wherein safe distances are approximately 4 times the flame height. Note that an LPG tank filled with high explosives would require a significantly greater standoff distance than if it were filled with LPG.

Adapted from: Emergency Response Guidebook

U.S. Department of Transportation, Pipeline and Hazardous Materials Safety Administration, Transport Canada, Secretariat of Transport and Communications, 2024

7.23.3 Fire Fighting a BLEVE

Fire fighters should do the following:

- Fight the fire from the maximum distance possible. If possible, use unmanned equipment such as a fixed fire monitor (deluge gun) or a ground fire monitor. These pieces of equipment are used to direct up to 7500 litres per minute onto a vessel or facility.
- Cool the container by flooding it with large amounts of water. Continue to cool after the fire is out.
- Do not direct water at the source of leak or at the pressure relief device (icing may occur).
- Leave the area immediately if you hear venting from the safety device or see discoloration of the tank.

7.24 Transportation Incident

7.24.1 Transportation Incident Safety

- Intervene to initiate the development of a safe and static incident scene.
- Identify the current and immediate hazards within the incident scene.
- Identify any hazards outside of the incident scene created by the accident.
- In the event of incidents involving or damaging electric service poles or transformer vaults:
 - Remain back an absolute minimum distance of 9 metres (30 feet) in all directions.
 - Restrict access to the area, permitting no entrance regardless of the need.
- In the event of uncontrolled fuel releases:
 - Restrict access and evacuate personnel from areas where an ignition and/or fire exposure is possible.

7.24.2 Action Plan for Transportation Incident

- Call 911.
- Establish roadway notification of the emergency incident.
- Survey the accident site from a safe distance and attempt to identify hazards.
- Isolate any present controllable hazards within the incident scene.
- Secure the incident scene and vehicles depending upon severity of incident (e.g. fatality).
- Assess and treat the injured, within level of training.
- Notify TDG if accident involves Dangerous Goods.

Identify the Accident Site to Roadway Users

- Utilize vehicles and or barriers to identify the roadway hazard and create an exclusion zone to prevent further accident occurrence:
 - Position a vehicle far enough back from the incident site, in both directions, such that on coming roadway users have the opportunity to identify the hazard and slow down to a safe stop.
 - Engage hazard lights of positioned vehicles.
 - Place additional vehicles in closer proximity to protect the incident scene from additional vehicle contact.
- Position traffic cones or road markers, as are available, to identify the accident site.
- Utilize accident bystanders who are uninvolved and uninjured to take positions safely off the roadway in high visibility vests close to the perimeter vehicles to wave down oncoming traffic alerting them to an incident scene.

Perform an Outside Accident Site Survey

- Survey the accident site from a minimum 9 metres (30 feet) safe distance, identifying all hazards outside of the accident site including:
 - Damaged utility poles.
 - Ground level power transformer vaults.
 - Any additional vehicles involved and not initially identified.
 - Location of injured; involved and uninvolved persons.
 - Discharged vehicle or transported fluids or materials.
 - Identify the discharge of gasoline or diesel fuel.
 - Identify any waterways or sources of fluids that could enter sewers etc.
 - Suspended loads or vehicles precariously positioned.

Perform an Inside Accident Site Survey

- Survey the incident scene within the 9 metres (30 feet) perimeter identifying all hazards inside the incident scene while maintaining a safe distance from any identified hazards including:
 - Damaged utility poles.
 - Ground level power transformer vaults.
 - Any additional vehicles.
 - Location of the injured.
 - Discharged vehicle or transported fluids or materials.
 - Suspended loads or vehicles precariously positioned.

Any tampering and/or altering of a vehicle's original position and/or controls (e.g. putting in park or out of gear, moving debris, letting air out of tires, etc.) should be documented and provided to investigators in order that investigation findings are not compromised (preferably with before and after photographs).

Stabilize the Accident Site

- Identify and restrict access to areas of uncontrollable hazard.
- Attempt to access each vehicle individually, assessing to ensure vehicle(s):
 - Ignition system is disengaged.
 - Automatic transmissions are in the “park” position.
 - Manual transmissions are in neutral gear, once the ignition is disengaged.
 - Parking brakes are engaged.
- Where access to the vehicle is not possible to secure the vehicle in a disengaged position:
 - Place larger debris or available materials under the wheels to provide a makeshift wheel block.
 - If possible, mark the location of vehicle component debris prior to moving, as this will assist any required investigations.
- If materials are not present to provide wheel blocking, pull the valve stems of each tire to secure the vehicle and document for investigators.
- Control any hazardous condition as is possible:
- Dilute or suppress fuel leaks.
- Identify exclusion zones due to uncontrollable hazards.

Triage and Treat the Injured Personnel

- Provide medical treatment only within level of training.
- Identify the location and injuries sustained by each individual involved in the accident.
- Remove persons slightly injured, uninjured or uninvolved from the immediate accident site to a safe controlled holding location away from any hazards of the accident site and on-coming roadway traffic.
- Protect in place any injured persons found within the vehicles.
- Gather uninjured personnel from the scene to assist with medical treatment as is available.
- Assess the safety of field medical treatment in the position found:
 - Where the injured person’s safety is threatened, they may be moved to prevent further significant injury.
- Identify and prioritize the injury treatment based on criticality of need.
- Ensure qualified personnel provide medical treatment within prioritized medical aid protocols.
- Treat for shock.
- Closely monitor the injured until relieved by arriving emergency responders.

Meet and Brief Emergency Responders

- Position personnel to meet and direct emergency responders to the accident site.
- Provide a scene safety and hazard briefing.
- Identify the number of injured.
- Identify the location of the injured and from which vehicle they belong.
- Identify the initial position found and condition of each of the injured.
- Identify the injuries sustained by each victim.
- Identify the medical treatment provided.
- Provide personal information on each victim as is available.
- Monitor the safety of the scene.
- Assist emergency responders within ability and level of training.
- Gather information regarding the medical treatment provider, the transport provider and the destination of medical treatment center.

7.25 Product Transportation Incident

The first priority of a product transportation incident is to protect the driver and the public from risk as well as containing and preventing the product from impacting the environment.

If a transportation incident involves propane, see BLEVE requirements.

The party in charge or control of the product (carrier) is responsible to remedy the dangerous occurrence. However, the ultimate responsibility remains with the Company (shipper). Products that may be shipped include produced water or higher risk Liquefied Petroleum Gas (LPG).

Response actions include:

- On public roadways, the Company will not assume the on-site command but will act on behalf of local police to respond to the incident.
 - Notify/activate police and report incident.
 - If applicable, Implement ERAP by contacting Emergency Response Assistance Canada, see Section 9 Federal Government Support Agencies.
 - Notify Transportation of Dangerous Goods Spill Department and provide the following information:
 - Location of incident and directions to site.
 - Name and contact number.
 - On-site response actions implemented.
 - Type of vehicle involved.
 - Type of container(s) involved and volumes.
 - Type of Dangerous Goods or environmentally sensitive products involved and volumes.
 - Copy of Safety Data Sheet (SDS).
 - Secure the incident scene from on-coming traffic.
 - Provide medical aid to the driver and passengers involved in the incident.
 - If possible, interview the driver and review the manifest for products, volumes and carrier company name.
 - Review SDS with the Emergency Response Guidebook for product hazards, PPE requirements, response action and public protection measures.
 - Assess the container integrity and secure the leak (if safe to do so).
 - Respond to public safety by reviewing the public protection plan.
 - Contain and clean up spilled product.
 - Keep a log of the time and sequence of events.
 - Record information on a Company incident report form.
 - Stay at site until relieved by additional Company personnel (if required).
 - Restrict access to the site immediately and preserve site for follow-up investigations.
- Clean up and repair as directed by the Incident Commander.

7.26 Hazardous Materials Incident**7.26.1 Hazardous Material Safety**

- Ensure the safety of site personnel and the public.
- Assess the potential exposure to human life.
- Assess the harm created by exposure to human life.
- Restrict the access to areas of potential exposure.
- Ensure the hazards associated with any product release are fully communicated.
- Activate emergency response agencies.
- Establish a safe incident scene.
- Decontaminate exposed personnel.

7.26.2 Action Plan for Hazardous Material Incident

- Identify the released material.
- Assess the hazard associated with the release.
- Identify any environmental impacts.

Initiating Incident Response

- Notify local emergency response agencies.
- Notify Company management.
- Establish a safe incident scene perimeter.
- Secure and restrict access to the area.
- Contain persons requiring decontamination.
- Evacuate persons from the area.
- Designate a holding area for evacuees.
- Identify safe access routes and communicate clearly and promptly to the responding agencies.
- Identify appropriate staging locations.
- Account for all personnel:
 - Number of persons involved.
 - Injured persons.
 - Injured employees.
 - Injured contractors.
 - Injured public.

Decontaminate Exposed Personnel

- Identify, contain and hold exposed personnel requiring decontamination in a safe location.
- Provide decontamination by removing clothing and thoroughly rinsing with large volumes of water.
- Control the runoff of the decontamination water.
- Remove person's clothing and shelter in a safe isolated location.
- Medically treat exposed personnel as is possible and only as trained.

Identify the Released Material

- Identify the material carrier.
- Identify vehicle number.
- Identify the trailer number(s).
- Identify the placard number.
- Acquire the shipping papers reference number.
- Identify the SDS reference number.
- Reference the CANUTEC Emergency Response Guide.
- Reference the AAR Guide, if applicable.

Assess the Hazards Associated with the Release

- Inhalation.
- Flammability.
- Toxicity.
- Water reactivity.
- Contact exposure hazard.
- Organic reactivity.

Evaluate the Release

- Identify the release type: static or dynamic.
- Maximum potential-volume of release.
- Current volume and rate of release.
- Outfall direction of the release.
- Identify the outfall exposure potentials.
 - Public exposures.
 - Natural waterways.
 - High impact environmental outfalls.
 - Low impact environmental outfalls.
 - Natural containment characteristics.

Identify Environmental Impacts

- Identify the current weather and potential impacts:
 - Temperature.
 - Chance of precipitation.
 - Wind conditions: strength and direction.
 - General grade of topography.
- Brief emergency responders on their arrival.
- Identify the medical treatment provider.
- Identify the receiving medical treatment center.

Meet and Brief Arriving Emergency Responders

- Position personnel to meet and direct emergency responders to the incident site.
- Provide a scene safety and hazard briefing.
- Identify the event timeline.
- Identify the released material(s) involved.
- Identify the hazards associated with the released material(s).
- Identify the personnel accountability.
- Identify the injuries present.
- Identify the chemical exposures present.
- Identify the decontamination procedures undertaken.
- Identify the environmental exposure and impacts.
- Identify the containment actions undertaken.
- Identify the current operational status of the facility.

7.27 Severe Weather Incidents

Wildfires, thunderstorms, tornadoes, hail, blizzards, high winds, and heavy rain can develop quickly and hit hard posing a threat to life and property. Municipal governments are responsible for informing the public and providing detailed information about the nature of the emergency.

7.27.1 Severe Weather Safety

Identify the immediate hazards associated with the impact of a severe weather incident to the facility or any facility egress routes. If at any time the facility is threatened by a severe weather incident, prioritize the preparations in accordance with:

- Safety of personnel.
- Environmental protection.
- Protection of facility assets.

Identify the safety risk associated with facility personnel weathering the severe weather within the protection of the facility vs. the risks of evacuation.

Effectively use of the lead time prior to the arrival of the severe weather to achieve either:

- Early evacuation to prevent exposure to unsafe conditions.
- Shelter in Place preparations including adequate food and water supplies.

Minimize personnel exposure to hazardous conditions by rescheduling services, deliveries and non-essential activities.

Account for secondary effects of severe weather e.g. icy roads, toppled trees, flooding etc. in risk assessments.

Response Plan for Severe Weather

- Prepare a virtual or mobile Command Post to sustain operations in the event of power loss or building damage including:
 - Pre-printed maps.
 - ICS wall charts.
 - Communication devices (satellite and cell phones, chargers etc.).
 - Portable generators and heaters.
- Sustain Command Post operations by hardening the building against storm damage.
- Identify the current status of any potential or impending severe weather.
- Identify the safety of the facility location with regard to severe weather impact.
- Assess the appropriateness of continuing current facility operations.
- Maintain personnel accountability throughout any facility evacuation process.
- Identify the facility's ability to provide protection for personnel during the severe weather.
- Brief facility personnel to provide incident information and current status.
- Identify incident contingency plan(s) for the timely and safe shutdown of facility operations and the protection of facility assets.

7.27.2 Wildfire

A wildfire is an uncontrolled fire in an area of combustible vegetation that occurs in the countryside or a wilderness area. A wildfire differs from other fires by its extensive size, the speed at which it can spread out from its original source, its potential to change direction unexpectedly, and its ability to jump gaps such as roads, rivers and fire breaks. Wildfires are characterized in terms of the cause of ignition, their physical properties such as speed of propagation, the combustible material present, and the effect of weather on the fire.

Action Plan for Wildfire Response

- Make contact with supervision to obtain current fire statuses and fire spread predictions:
 - Location.
 - Spread direction.
 - Rate of growth.
 - Evacuation areas, evacuation routes, and proximity of facility areas under mandatory evacuation orders.
 - Provide and obtain contact numbers for periodic information and status updates.
- Identify actions and time required to safely shutdown the facility operations:
 - The safe evacuation of the personnel remains paramount.
 - Protect company assets by shutting down early in a managed and organized fashion.
 - Consult Company management for guidance.
- Brief all personnel as to the current status of the wildfire and its:
 - Location.
 - Direction and rate of fire growth/spread.
 - Potential shutdown procedures.
 - Contingent evacuation procedures.
- Identify and specify the safe egress route including any new safe mustering location for all evacuating personnel.
- Maintain a common communication link with all evacuating personnel groups.
- Maintain a tracking and accountability system during the evacuation to:
 - Identify the current location of each evacuating individual.
 - Identify and confirm the safety of each evacuating individual.
- Contact the supervisor and provide the current status of the facility and evacuation status of the personnel.

7.27.3 Tornadoes

Tornadoes form suddenly, are often preceded by warm humid weather, and are always produced by thunderstorms, although not every thunderstorm produces a tornado. Choose an appropriate shelter.

Tornado Warning Signs:

- Severe thunderstorms with frequent thunder and lightning.
- An extremely dark sky sometimes highlighted by green or yellow clouds.
- A rumbling sound, such as a freight train might make or a whistling sound such as a jet aircraft might make.
- A funnel cloud at the rear base of a thunder cloud often behind a curtain of heavy rain or hail.

What To Do in Case of a Tornado:

- Take cover immediately, if you are in a building seek shelter under a heavy table or desk, stay away from windows and outside walls and doors.
- Do not get into your car. Seek shelter in a building with a strong foundation. If no shelter is available, then lie down in a ditch away from automobiles or mobile homes.
- In all cases, get as close to the ground as possible, protect your head, and watch out for flying debris.

7.27.4 Lightning

Lightning is a powerful sudden flow of electricity (an electrostatic discharge) accompanied by thunder that occurs during an electric storm. To estimate how far away the lightning is count the seconds between the flash of lightning and the thunderclap. If you count fewer than five seconds, take shelter immediately, you do not want to be the tallest object in the area.

If Caught Outdoors:

- Avoid putting yourself above the surrounding landscape. Seek shelter in low-lying areas such as valleys, ditches, and depressions but be aware of flooding.
- Stay away from water. Get to land as quickly as possible if you are on the water. Lightning can strike the water and travel a substantial distance from its point of contact.
- Stay away from objects that conduct electricity, such as tractors and metal fences.
- Avoid being the highest point in an open area or holding an object that can make you the tallest object and a target for lightning.
- You are safe inside a car during lightning but be aware of downed power lines which may be touching your car. You are safe inside the car, but you may receive a shock if you step outside.
- In a forest, seek shelter in a low-lying area under a thick growth of small trees or bushes.
- Keep alert for flash floods, sometimes caused by heavy rainfall, if seeking shelter in a ditch or low-lying area.

7.27.5 Floods

A flood is an overflow of water that submerges land which is usually dry. Flooding may occur as an overflow of water from waterbodies, such as a river or lake, in which the water overtops or breaks levees, resulting in some of that water escaping its usual boundaries, or it may occur due to an accumulation of rainwater on saturated ground.

What To Do in Case of Flooding:

- For information listen to the radio, watch television, check Government Agency websites or follow Social Media.
- Be aware that flash flooding can occur. If there is any possibility of a flash flood, move immediately to higher ground. Do not wait for instructions to move.
- Be aware of stream, drainage channels, canyons and other areas known to flood suddenly. Flash floods can occur in these areas with or without typical warnings such as rain clouds or heavy rain.
- Do not walk through moving water. Six inches of moving water can make you fall. If you have to walk in water, walk where the water is not moving. Use a stick to check the firmness of the ground in front of you.
- Do not drive into flooded areas. If floodwaters rise around your car, abandon the car and move to higher ground when water is not moving or not more than a few inches deep. You and the vehicle can be swept away quickly. If your vehicle is trapped in rapidly moving water, stay in the vehicle. If the water is rising inside the vehicle, seek refuge on the roof.
- Do not park your vehicle along streams, rivers or creeks, particularly during threatening conditions.
- Sandbag and/or build a dike if possible.

7.27.6 Seismicity

Earthquakes are caused by subsurface breaking and/or shifting of rock, which will release small to extremely large forces of energy through the Earth's lithosphere creating seismic waves. These seismic waves can cause severe damage to drilling rigs, well-sites, pipelines, facility buildings etc. Gas, electricity and phone services are also in danger of being affected. Landslides, avalanches, and flash floods can also be triggered. Earthquakes can occur at any time of the year. After an earthquake there is the possible danger of an "After-shock" which can occur in the hours, days weeks or even months after the initial wave. Some earthquakes could actually be foreshocks and a larger earthquake could occur.

During an earthquake

Wherever you are when an earthquake starts, take cover immediately. Move to a nearby safe place if need be. Stay there until the shaking stops.

If you are indoors: "DROP, COVER, HOLD ON"

- Stay inside.
- **Drop** under heavy furniture such as a table, desk or any solid furniture.
- **Cover** your head and torso to prevent being hit by falling objects.
- **Hold** onto the object that you are under so that you remain covered.
- If you can't get under something strong, or if you are in a hallway, flatten yourself or crouch against an interior wall.
- Stay away from windows and shelves with heavy objects.

If you are outdoors

- Stay outside.
- Go to an open area away from buildings.

If you are in a vehicle

- Pull over to a safe place where you are not blocking the road. Keep roads clear for rescue and emergency vehicles.
- Avoid bridges, overpasses, underpasses, buildings or anything that could collapse.
- Stop the car and stay inside.
- Listen to your car radio for instructions from emergency officials.
- Do not attempt to get out of your car if downed power lines are across it. Wait to be rescued.
- Place a HELP sign in your window if you need assistance.

AVOID the following in an earthquake

- Doorways. Doors may slam shut and cause injuries.
- Windows, bookcases, tall furniture and light fixtures. You could be hurt by shattered glass or heavy objects.
- Downed power lines - stay at least 10 metres away to avoid injury.

*After an earthquake***Stay calm. Help others if you are able.****After an Earthquake Procedures:**

- Be prepared for aftershocks.
- Listen to the radio or television for information from authorities. Follow their instructions. Place telephone receivers back in their cradles; only make calls if requiring emergency services.
- Put on sturdy shoes and protective clothing to help prevent injury from debris, especially broken glass.
- Check your building for structural damage and other hazards. If you suspect the building is unsafe, do not re-enter.
- If you have to leave the building, take your emergency kit and other essential items with you. Post a message in clear view, indicating where you can be found. Do not waste food or water as supplies may be interrupted.
- Do not light matches or turn on light switches until you are sure there are no gas leaks or flammable liquids spilled. Use a flashlight to check utilities and do not shut them off unless damaged. Leaking gas will smell.
- If tap water is still available immediately after the earthquake, fill a bathtub and other containers in case the supply gets cut off. If there is no running water, remember that you may have water available in a hot water tank (make sure water is not hot before touching it) and toilet reservoir (not the bowl).
- Carefully clean up any spilled hazardous materials. Wear proper hand and eye protection.
- Check on your co-workers. Organize rescue measures if people are trapped or call for emergency assistance if you cannot safely help them.
- Place a HELP sign in a window if you need assistance.
- Beware of secondary effects. Although ground shaking is the major source of earthquake damage, secondary effects can also be very destructive. These include landslides, saturated sandy soils becoming soft and unstable, and flooding of low-lying areas.

Department of Public Safety and Emergency Preparedness Canada

7.28 Wildlife

7.28.1 Wildlife Incidents and Mortalities

Wildlife observations should be tracked on a daily basis (nuisance or not) to determine which wildlife are in the area and whether activities are attracting wildlife. Mitigations may need to be incorporated to reduce the potential risk to workers and wildlife.

Wildlife mortalities should be reported to your supervisor and appropriate Company Representative immediately.

The following information should be recorded and reported:

- Nature of the incident (i.e., road collision).
- Type of species and number of individuals.
- Location of incident/collision.
- Time of incident/collision.
- Details of incident/collision (e.g., if animal was clipped or hit directly).

7.28.2 Wildlife Awareness

There are a number of different species of wildlife that can present hazards to workers.

Wildlife awareness is not limited only to working in remote areas but should be oriented to the habitat of the work area and included into local hazard assessments. Workers are required to follow the practices developed to manage local wildlife hazards.

7.28.3 Working in Wildlife Habitat

- Make enough noise to prevent surprising wildlife.
- Watch for tracks and signs.
- Young animals are usually well-hidden. However, if you do stumble upon babies, do not approach or attempt to pick them up. Leave the area immediately, as a female will defend her young.

If You Encounter Wildlife:

- Never approach wildlife. Although animals will normally avoid a confrontation, animals are unpredictable. Animals feeding may be dangerous.
- Always give animals an avenue of escape.
- Stay calm. Talk in a confident voice.
- Do not run. Try to back away slowly.
- Do not turn your back on wildlife.
- Do all you can to enlarge your image. Don't crouch down or try to hide. Pickup sticks or branches and wave them about.

7.28.4 Bears

All employees should be informed of the following:

- types of bears in the area
- recent bear activity
- general policies and procedures in place to mitigate potential conflict with bears
- actions to be taken if a bear is sighted including reporting procedures

Monitoring Work Sites

Employees working away from the main site may occasionally find themselves working in an area of high bear hazard. Normally work should be halted and workers removed until the bear hazard is no longer present. However, if work can not be shut down, a qualified bear monitor should be assigned to alert workers when bears are present and move people out of harms way. Only in extreme cases would bear monitors displace the bears in order for work to continue.

Monitoring Camps

Problem encounters with bears are more likely in a camp situation than a chance encounter in the field or at work sites. When bears are active in the area, monitors may be called upon to provide bear detection services and to alert personnel of the presence of a bear on site. If necessary, the bear monitor will attempt to deter the bear. Bear monitors may also advise on preventative measures within a camp, including altering camp locations or configurations as appropriate.

What to do if you see a Bear

If It does not approach:

- If spotted in the distance, do not approach the bear. Make a wide detour or leave the area immediately.
- If you are at close range, do not approach the bear. Remain calm, keep it in view. Avoid direct eye contact. Move away without running.

If the bear approaches:

- If the bear is standing up, it is usually trying to identify you. Talk softly so it knows what you are. If it is snapping its jaws, lowering its head, flattening its ears, growling or making 'woofing' signs, it is displaying aggression.
- Do not run unless you are very close to a secure place. Move away, keeping it in view. Avoid direct eye contact. Dropping your pack or an object may distract it to give you more time. If it is a grizzly, consider climbing a tree.

What to do if a Bear Attacks

Your response depends on the species and whether the bear is being defensive or offensive. Bears sometimes bluff their way out of a confrontation by charging then turning away at the last moment. Generally, the response is to do nothing to threaten or further arouse the bear. While fighting back usually increases the intensity of an attack, it may cause the bear to leave.

Every encounter is unique, and the following are offered as guidelines to deal with unpredictable animals and potentially complex situations.

Grizzly Attacks from Surprise (defensive)

- Do nothing to threaten or further arouse the bear.
- Play dead. Assume the 'cannonball position' with hands clasped behind neck and face buried in knees.
- Do not move until the bear leaves the area. Such attacks seldom last beyond a few minutes.

Black Bear Attacks from Surprise (defensive)

- Playing dead is not appropriate. Try to retreat from the attack.

Grizzly or Black Bear Attacks Offensively (including stalking you or when you are sleeping)

- Do not play dead.
- Try to escape to a secure place (car or building) or climb a tree unless it is a black bear.
- If you have no other option, try to intimidate the bear with deterrents or weapons such as tree branches or rocks.

*Equipment/Deterrent***Bear Spray**

- Must be used at very close range and should be used downwind only to avoid getting on yourself.
- It is indiscriminate and can cause extreme irritation to both the bear and the user.
- Will only work if fired at a bear, IT IS NOT A REPELLENT.
- If discharged, wash all your clothing, packs and any exposed skin with soap to help avoid attracting more bears with the smell.
- Works on cougars.

Bear Bangers

- Should be fired up into the air between you and the bear.
- Do not fire the bear bangers at or behind the bear.

7.28.5 Elk

Elk can be aggressive and attack without warning. During the fall mating season (August – September) male are particularly belligerent. During the spring calving season (May – June) female elk aggressively defend their young. DO NOT approach elk in any season as they are DANGEROUS.

7.28.6 Moose

A moose encounter has the potential to be just as dangerous as a bear encounter. Therefore, similar measures must be taken to avoid these large ungulates. Moose are especially aggressive in the spring (calving season) and the fall (rutting season). Moose are most active in the early hours of the morning. However, one can expect to meet a moose any time of the day, especially in marshy woodland and around lakes. The best method of avoiding unwanted encounters with wildlife is to make a lot of noise. Hence, while practicing good bear-avoidance measures, moose will also be alerted of your presence. As harmless as a moose encounter may seem, it is important to have a high level of respect for the damage and injury these animals can incur if they feel threatened. Hence, if a moose is encountered, a minimum of 100 m must be put between yourself and the animal. If the moose remains stationary, you should cautiously move away from the animal, monitoring its behaviour in the process. Signals such as whether its ears are forward or back, or a lowering of the head are good indicators of aggressiveness (forward and erect is the animal being alert, back and down over the head is aggressive). React according to the signals being sent by the animal. Also, the direction you use in moving away should not interfere with any natural escape routes the moose may want to take. Similarly, it is very important not to position yourself between two moose (cow and calf or two rutting males).

If a moose feels threatened, it may charge at the person that has invaded its space. Moose are not predatory animals. Some examples of aggressive behaviour that may be exhibited are flattening of the ears and approaching humans. Unlike in a bear encounter, walking quickly, or if safe to do so, running away from an angry moose will not lead to a sustained attack; it will likely prevent it. Should the moose charge regardless, the best method of defense is to move behind a big tree, light standard or other large stationary object. Continue to try to get away from the animal while always keeping large solid objects between yourself and the moose. It is imperative that no false sense of security is attained once a large solid object is between a person and an angry moose, as moose are very capable of kicking accurately with their forelegs around a tree trunk. Although it is best to try to get away from the animal, this is sometimes difficult, particularly if the area is challenging to move through.

[REDACTED]

[REDACTED]

[REDACTED]

[REDACTED]

[REDACTED]

- [REDACTED]
- [REDACTED]
- [REDACTED]
- [REDACTED]
- [REDACTED]

[REDACTED]

- [REDACTED]
- [REDACTED]
- [REDACTED]
- [REDACTED]
- [REDACTED]

[REDACTED]

- [REDACTED]
- [REDACTED]
- [REDACTED]
- [REDACTED]
- [REDACTED]
- [REDACTED]
- [REDACTED]
- [REDACTED]

[REDACTED]

- [REDACTED]
- [REDACTED]
- [REDACTED]
- [REDACTED]

[REDACTED]

[REDACTED]

[REDACTED]

[REDACTED]

[REDACTED]

[REDACTED]

[REDACTED]

- [REDACTED]
- [REDACTED]
- [REDACTED]
- [REDACTED]

[REDACTED]

- [REDACTED]
- [REDACTED]
- [REDACTED]
- [REDACTED]
- [REDACTED]
- [REDACTED]
- [REDACTED]
- [REDACTED]
- [REDACTED]
- [REDACTED]

[REDACTED]

[REDACTED]

[REDACTED]

[REDACTED]

[REDACTED]

- [REDACTED]
- [REDACTED]
- [REDACTED]
- [REDACTED]
- [REDACTED]

8.0 POST EMERGENCY

8.1 Overview

The decision to stand-down the emergency, allow stakeholders to return to the incident area and resume normal operations is made by the Incident Commander and CEOC Director in conjunction with the Regulatory Authority.

The CEOC Director and Incident Commander ensure that the CEOC Command Team and Site Command Team carry out post-incident activities as required, including the following tasks:

- Emergency stand-down notification.
- Public assistance and support.
- Clean-up and repair.
- Ongoing media communication.
- Post-incident documentation.
- Post-incident Investigation.
- Critical Incident Stress Debriefing.
- Post-incident Report.

8.2 Responsibility

The Incident Commander and CEOC Director manage the following post-incident activities:

- Deactivate the emergency response operations.
- Establish post-incident goals.
- Delegate the responsibility for the completion of post-incident tasks.
- Ensure that all contacts are notified about the emergency stand-down.
- Ensure all post-incident activities are documented.
- Arrange for critical incident stress debriefing sessions as necessary.
- Conduct a debriefing meeting for all response team members.

8.3 Critical Incident Stress Debriefing (CISD)

Any individual directly involved in a critical incident and/or experiencing strong feelings relating to the event should be debriefed to encourage communication about their feelings and reactions without being judged or blamed.

Individuals include:

- Operating Personnel directly involved.
- Co-workers.
- Management.
- Contractors.
- Family Members.
- Community Members.

The Incident Commander and CEOC Director ensure the following actions are completed:

- When practical after a serious incident, mobilize professionals who are trained in CISD.
- Explain to the participants that the debriefing is confidential. CISD meetings do not judge or lay blame. Recording devices at these meetings is prohibited.
- Do not schedule more than twenty (20) people to do a debriefing session. Advise the CISD professional about the size of the session and provide information about the attendees before the session starts.
- Debriefing should occur 24-72 hours post-incident.

Objectives of the debriefing are to:

- Minimize the severity and duration of the trauma.
- Normalize feelings and reactions.
- Acknowledge each individual's personal experience.
- Provide support.
- Provide information on crisis reactions and stress management.

8.3.1 Key Reactions to Stress

PHYSICAL	COGNITIVE (PERCEIVED)
Headaches	Poor Concentration
Dizziness	Slow Thinking
Disorientation	Memory Lapses
Fatigue	Loss of Objectivity
Digestive Problems	Flashbacks
Frozen Fright	Abnormal Pondering
Loss of Control over Body Functions	Difficulty Processing Information
Numbness	Distorted Thinking
Increased Heart Rate	
Heightened Sensory Perception	
Sleep Disruptions	

8.4 Public Assistance and Support

The Incident Commander oversees the following actions:

- Verifies that the incident area is safe to re-enter in consultation with applicable Regulatory Authorities, if required.
- This may involve ensuring all equipment and debris are removed from public roadways. Any remaining hazardous areas must be cordoned off.
- Ensures that all sheltered or evacuated residents are contacted and informed that the incident is over.
- Secures the evacuated area until the evacuees have returned to their homes and businesses.
- Confers with the CEOC Director about sending a company representative to visit all members of the public who were affected.
- Ensures that the residents are provided with post-incident contacts and telephone numbers.
- Confers with the CEOC Director to schedule a follow-up meeting(s) with the residents to clearly explain the incident and address their concerns.
- Ensures resident expense and damage claims are addressed.

8.5 Investigation

Site and evidence preservation is extremely important after an unplanned event. Senior Company Management must be contacted, and a decision will be made whether to send personnel or a third-party contractor to the site to conduct an investigation.

If an incident involving equipment at a site that results in a death, the site must be secured. The Incident Commander must ensure that the location is not disturbed (unless protecting the health or safety of other workers or aiding an injured person) until the police have investigated the accident and an OHS inspector directs otherwise.

Third party investigations by police, insurance companies, and others may be required. It is important to co-operate with all third-party investigators; therefore, the following guidelines will apply:

- Do not allow third party investigators on-site, unless authorized by the Incident Commander; this is to ensure everyone's safety. Obtain the name, title, address, and telephone number of all inspectors.
- If access is granted to the site, ensure that third party investigators are escorted while on company property and, for their safety, denied access to any hazardous areas. Inspectors must not be left unattended.
- Ensure inspectors receive only the information they request and limit tours to the specific area the investigator has asked to investigate.
- Always tell the truth. Do not speculate.
- Wait until legal counsel is present before answering questions if the inspector suggests that the statements may be used as evidence or indicates that you have the right to counsel.
- Copy all documents given to third parties, including investigators.

An internal investigation can be a valuable learning experience. The findings can be applied to other operations and improve the emergency response system. An investigation can also result in improved incident prevention methods and operating practices.

8.6 Clean Up and Repair

The Incident Commander oversees the following actions:

- Ensures that site clean-up is managed in a timely manner. The remediation phase of the site clean-up may be filled by an environmental specialist.
- Ensures that all hazardous waste is disposed appropriately according to applicable regulations.
- Ensures the priority is given to clearing debris and restoring the site to normal operating conditions after the government and company investigations are complete.
- Ensures that all equipment is demobilized, cleaned and inspected for contamination.
- Ensures all roadblocks, staging area and detour equipment is demobilized.
- Ensures that all clean-up and repair actions follow safety and environment policies and safe-work procedures.

8.7 Post-Incident Notifications

The objective in post-incident notifications is to ensure that the best possible communication with stakeholders are made; to sustain Company core value commitments and capture any outstanding or legacy issues.

All affected parties are to be advised of the post-incident status of the incident:

- Company employees and contractors.
- Joint Venture Owners.
- Mutual Aid partners.
- Evacuees.
- Members of the Public who were involved.
- Government Agencies.
- Non-Governmental Organizations (NGOs).

Typically, this should be done through personal calls (supported by media releases) by the CEOC Information Officer. All communications are to be approved by the CEOC Director and Legal.

8.8 Incident Documentation/Company Records

The Incident Commander and the CEOC Director instruct their teams to complete the following duties:

- Collect and compile all forms and documentation for the incident, including all electronic records.
- Securely store all incident documentation. The protection of records is extremely important to ensure the evidence is complete and unchanged.
- Obtain all photographs and videos of the incident site and response. All photographs of the incident site which have been taken are considered Company material and are to be properly documented.
- Ensure that pages and checklists from all emergency response manuals are replaced.
- Prepare letters thanking support agencies, groups and individuals who provided assistance. Mention names of key individuals in correspondence.
- Company records must be reviewed by legal counsel before they are released.

8.9 Post-Incident Debriefing and Incident Assessment

The Incident Commander should follow the checklist below to ensure the following items and/or personnel are available at the debriefing session:

- A comfortable classroom/conference area large enough to conduct a post-incident debriefing.
- Refreshments.
- Map of Response Area.
- Copy of Incident Logs and all other Response Forms.
- Any Video Tape and/or Photos of the incident that may be helpful during the debriefing.
- If videotape is used, secure a video player and monitor.
- Flip chart or white board.
 - Masking tape to hang flip chart pages.
 - Drawing markers (various colors).
- Copy of Company's ERP.
- Note-taking materials for attendees (pads, writing instruments).
- Copies of any planning cycle plan(s).
- Copies of Daily Site-Specific Safety and Health Plans.

8.9.1 Session Guidelines

The debriefing should be facilitated by the Incident Commander. The following provides some session guides:

- Awareness on room safety e.g. emergency alarms, evacuation procedures for those participants not familiar with the facility.
- Objective and agenda of meeting.
- Need for openness and honesty.
- Emphasize that the debriefing is to provide learning and response improvement opportunities - not fault finding.
- Conduct session in a non-confrontational manner.
- Allow everyone involved in the response to have an opportunity for input.
- Have a Scribe available to document comments and action items.
- Do not solve the issues but record as action items to be reviewed and addressed later.
- Participants should not try to justify their actions but can provide clarification if requested by the facilitator(s).
- Introduce the participants and the organizations they represent e.g. location and role.
- Conclude the meeting by communicating future action plans e.g. "where do we go from here?"

8.9.2 Site Response Team Debriefing Questions

- Did pre-emergency planning efforts occur relating to this particular incident?
- Did pre-emergency training take place relating to this particular type of incident?
- Was the Incident Command System (ICS) promptly activated?
- Was ICS terminology implemented early on during the incident and utilized throughout the incident?
- Was the location of the Command Post established early on?
- Was a safe Staging Area established early on during the incident?
- Did responders receive thorough initial briefings before assignment?
- Was a Check-In/Check-Out area established early on (preferably at Staging)?
- Were all employees accounted for early on during the incident?
- Did responders preplan which escape or egress routes to utilize during emergency operations?
- Was there necessary command and control of resources to prevent freelancing?
- Were all hazardous substances and conditions identified before responders took direct action?
- Were the planning zones established by responders before action was taken?
- Did the On-Site Group Supervisor take action to ensure that all responders utilized the proper PPE?
- Were adequate resources ordered early on?
- Were planning cycle time guidelines utilized?
- Was employee evacuation undertaken?
- Were all required permits obtained prior to hazardous operations?
- Was site security and control provided?
- Were Incident goals and objectives established?
- Did emergency medical treatment occur in a timely fashion?
- Was PPE utilized in a safe and effective manner?
- Were direct mitigation efforts taken?
- Was action taken early enough to provide resources to perform monitoring?
- Was action taken early enough to provide resources to adequately complete source control efforts?
- Was a Site-Specific Health and Safety Plan completed?

8.9.3 CEOC Team Debriefing Questions

- Did someone establish a CEOC early on and implement the Incident Command System (ICS)?
- Were public notifications made in a timely manner?
- Were governmental notifications made in a timely manner?
- Was action taken early on to make required telephone notifications other than public and government?
- Was ICS terminology implemented early enough during the incident?
- Was action taken early enough to provide resources for Public Affairs and Community Relations Assistance?
- Was action taken to provide a 12-Hour Plan?

*Response Actions Debriefing Questions***Detection**

- Was the incident detected promptly?
- How was it detected?
- By whom?
- Could it have been detected earlier? How?
- Are there any instruments or procedures which might aid in detection?

Notification

- Was Management notified promptly?
- Was Management response appropriate?
- Was Head Office notified promptly?
If so, why, how and who? If not, why not?

Evaluation

- Was the magnitude of the problem assessed correctly at the start?
- What means were used for this assessment?
- Are there any guides or aids to assist evaluation?
- What sources of information were available on public/structures in the area that could be at risk?
- What sources of information were available on winds and on water currents?
- Was information adequate?
- Was the information useful (and used) for trajectory forecasts?
- Were the forecasts realistic?
- Do we have adequate information on product properties?
- Do we need additional information on changes of product properties with respect to time (e.g. as a result of weathering) and other processes?

Mobilization

- What steps were taken to mobilize incident countermeasures?
- What resources were used?
- Was mobilization prompt?
- Could it have happened faster, or should it have been?
- What about mobilization of manpower resources - timely?
- Were the local response co-operatives or contractors used appropriately?
- How could this be improved?
- Was it appropriate to mobilize Head Office resources and was this effected promptly?
- What other corporate resources were available and were they identified and used adequately?

Response - Strategy

- Is the Company ERP an adequate response plan?
- Is it flexible enough to cope with unexpected events?
- Does the plan include clear understanding of local environmental sensitivities?
- What was the initial strategy for response to the incident?
- Is the strategy defined in the response plan?
- How did the strategy evolve during the incident and how were the changes implemented?
- What caused the changes?
- Are there any improvements needed? More training?

Response – Resources Used

- What resources were mobilized?
- How were they mobilized?
- How did utilization change with time? Why?
- Were the following resources used effectively:
 - Contractors?
 - Government agencies?
 - Company resources?
 - Co-operatives?
 - Mutual Aid?
 - Volunteers?
 - Consultants?
 - Others?
- What changes would have been useful?
- Is there adequate knowledge of resource availability?

Response – Effectiveness

- Was containment effective and prompt?
- How could it have been improved?
- Are additional resources required for containment?
- Was recovery effective and prompt?
- How could it have been improved?
- Are additional resources required for recovery?

Command Structure

- Who was initially in charge of the response?
- What sort of organization was initially set up?
- How did this change with time? Why?
- What changes would have been useful?
- Was there adequate surveillance?
- Were communications adequate?
- What improvements are needed? (Hardware, procedures, etc.)
- Was support from financial services adequate? Prompt?
- Should there be any changes?
- Is more planning needed?

Measurement

- Was there adequate measurement or estimation on the magnitude of the incident or volume of material released?
- Was there adequate measurement or estimation of the volume of product recovered?
- Should better measurement procedures be developed for either phase of operations?
- What would be appropriate and acceptable?

Government Relations

- What are the roles and effects of the various government agencies involved?
- Was there a single point of contact for the government agencies?
- Should there have been better communication with the agencies?
- Were the agencies adequately informed at all stages?
- Were too many agencies involved?
- Are any procedural changes needed to manage government relations?
- Was there agreement with the agencies on criteria for clean-up?
- How was this agreement developed?

Public Relations

- How were relations with the media handled?
- What problems were encountered?
- Are improvements needed?
- Was public outcry serious? How could it have been reduced?
- What communication systems were engaged by public and media (e.g. social media?)

8.10 Post-Incident Reports

The severity of an incident determines the report requirements.

Post-incident reports that are restricted to facts are limited to indisputable information such as the location of the incident, when the incident occurred, who responded, the number of injuries or casualties, and other information of this nature.

The report should include the following:

- A general description of the incident.
- Description of the response, containment, and recovery efforts.
- Area and site rehabilitation program.
- Recommendations for preventive measures in the future.
- Copy of personnel statements.
- Photographs illustrating the incident.
- Cost analysis for lost production, facility repairs, land reclamation, and community compensation.

A post-incident report contains analyses and evaluation of the incident. The report provides advice on how to prevent a recurrence and makes emergency preparedness recommendations. In addition, it may identify the immediate and basic causes.

Issues related to liability and responsibility may arise from the analysis of the report.

Reports that define responsibility, liability or corrective actions may have to be presented during legal proceedings. In such cases, however, the report may be protected from the disclosure by the legal doctrine of privilege. Any report that relates to the causation or liability of the company for an incident should be privileged and not given to a plaintiff in legal proceedings. A report that is not reviewed by a Company lawyer and that has been requested by a third-party legal counsel; should be addressed to Company legal counsel.

In addition to company reports, independent report(s) may be prepared by government agencies.

8.11 Cause and Liability Report

Cause and Liability Reports are privileged and confidential. They are prepared at the request of legal counsel in contemplation of litigation.

Cause and liability reports should be clearly separated from the reports that document factual matters and set out the remedial actions.

Privileged reports may include the following information:

- A description of the sequence of events that led up to the incident, during the incident and following the incident.
- Details related to the potential severity and the potential for frequency of recurrence. This suggests the importance of investigation and priority for action.
- An analysis including a logical determination of the cause of the incident.
- Evaluation of the emergency response:
 - On-site remedial procedures.
 - Safety standards that were applied during the response.

- Internal notification and communication systems.
- Effectiveness of media, government liaison or community relations efforts.
- Public safety actions.
- Actions taken to temporarily reduce the risk.
- An assessment of any potential legal or environmental issues that may be raised because of the incident or because of the company's responses.
- A plan to reduce the risk of a similar incident, including recommendations for the following actions:
 - Future actions.
 - Design changes and operating procedure changes.
 - Improvements to the emergency preparedness program.

8.12 Incident Investigations

Incidents in the work environment must be thoroughly investigated and reported to ensure every effort is made to identify and correct underlying causes. In every emergency involving a fatality, serious injury and loss or significant damage to Company property, corporate officials will either provide assistance with or take the lead in an incident investigation.

Particular care must be exercised to ensure that all evidence is preserved in its original state.

Where loss or damage to Company property or loss of revenue has occurred, evidence will not be disturbed until permission has been received from the Insurance Company adjuster and/or any government agencies involved.

Work within the incident area is only permitted in order to make an incident scene safe or to preserve equipment against loss.

Examples: Lowering a suspended load or draining water from equipment to prevent freezing damage.

All such work must be done in a manner that preserves the incident scene as much as possible.

Where an injury or fatality has occurred, the incident scene may be disturbed to preserve life and/or prevent catastrophic loss but must be proportional to the disruption of evidence.

Example: Isolation of equipment to prevent a spill to water shed.

Every attempt should be made to obtain permission for re-entry to an incident scene from the Jurisdiction having authority.

8.12.1 Serious Injury/Fatality Investigations

Following an incident where a fatality or a serious injury has occurred, government agency representatives will likely decide to carry out an investigation into either the extent or cause of the injury/fatality.

After presenting their credentials, these representatives are to be afforded full co-operation in the performance of their duties. Work at the scene of the injury/fatality may not be resumed until permission has been obtained from the various agencies involved.

8.12.2 Insurance Investigations

Insurance companies may wish to conduct investigations of their own into an incident. Once they have shown their credentials, they must be accompanied by a senior Company employee.

Access to an incident scene is predicated on the scene being safe and the persons entering the scene following Company Health and Safety requirements (e.g. PPE, etc.).

9.0 JURISDICTIONAL REQUIREMENTS

Federal and provincial/state specific emergency response regulations and guidelines are identified in the following sections.

9.1 Spill & Release Reporting Requirements

Spill & Release Reporting Requirements

All spills must be reported to your Environment Specialist

Reportable Quantities						
		Alberta <i>(see Note 1)</i> Any release that may cause and adverse effect must be reported		Federal	British Columbia <i>(see Note 2)</i> All releases must be reported, regardless of a minimum reportable quantity, if the release of a "polluting substance" is causing "pollution".	
Product	Onsite	Offsite	Transportation <i>(see Note 3)</i>		Onsite	Offsite
Spills						
Crude oil, condensate, emulsions, diluent, etc.	2 m ³ , or any quantity not confined to site.	All spills. Any spill from a pipeline.	Any quantity that endangers public safety		100 L	100 L, or any spill from a pipeline.
Produced water	2 m ³ , or any quantity not confined to site	All spills. Any spill from a pipeline.	Any quantity that endangers public safety		200 L	2 m ³ or any spill from a pipeline.
Diesel fuel, gasoline and other refined flammable liquids (Class 3)	200 L	200 L	Any quantity that endangers public safety		100 L	100 L
Used Glycol (Due to BTEX)	25 L (or see Note 1)	25 L (or see Note 1)	Not Regulated		25 L (or see Note 2)	25 L (or see Note 2)
Methanol (New or used)	200 L	200 L	Any quantity that endangers public safety		100 L	100 L
Lube oil (New or used)	200 L (or see Note 1)	200 L (or see Note 1)	Not Regulated		100 L	100 L
Oilfield wastes (See Note 4)	2 m ³ , or any quantity not confined to site	All spills.	Any quantity that endangers public safety		Note 4	Note 4
Molten sulphur or flammable solids (Class 4)	25 kg	25 kg	Any quantity that endangers public safety		25 kg	25 kg
Pesticides (See Note 4)	Reportable quantity dependent on product classification.		Any quantity that endangers public safety		Reportable quantity dependent on product classification.	
Toxic substances (Class 6.1)	5 kg or 5 L	5 kg or 5 L	Any quantity that endangers public safety		5 kg or 5 L	5 kg or 5 L
Corrosives (Class 8)	5 kg or 5 L	5 kg or 5 L	Any quantity that endangers public safety		5 kg or 5 L	5 kg or 5 L
Other refined products (See Note 4)	Reportable quantity dependent on product classification.		Any quantity that endangers public safety		Reportable quantity dependent on product classification.	
Air releases						
Natural gas	Any release from a pipeline and any other release >30,000 m ³ (See Note 5).	Any quantity that could pose a danger to public safety or 50 kg (non-pipeline)	10 kg, if there is a breakage in a pipeline or fitting operated above 100 psi that results in a sudden and uncontrolled release of natural gas.		Any quantity that could pose a danger to public safety or 50 kg (non-pipeline).	
Report to:						
Upstream produced fluids and natural gas	Alberta Energy Resources (AER) field office Bonnyville: 780-826-5352 Edmonton: 780-642-9310 Drayton Valley: 780-542-5182 Red Deer: 403-340-5454 Fort McMurray: 780-743-7214 Grande Prairie: 780-538-5138 Slave Lake: 780-843-2050 Medicine Hat: 403-527-3385 Oral report immediately to above. A written report may be requested. Report any pipeline release to AER and notify landowner.			Ministry of Emergency Management and Climate Readiness 1-800-663-3456 Oral report immediately to above. Written report only required if requested by the BCER in accordance with BCER Emergency Response Plan Requirements, Section 4.8. for BCER regulated/permitted assets, an update to ministry and end of spill report (entered into KERMIT within 24 hours) is only required for the following: <ul style="list-style-type: none"> It is a Level 1, 2, or 3 emergencies (i.e., anything above the minor notification requirement) It is a pipeline asset It is requested by the BCER 		
Other substances or TDG releases	Alberta Environment (AENV) 1-800-222-6514; Fax: 780-427-3178 TDG releases to be reported to local police and 1-800-272-9600. Oral report immediately to above. Written report to AENV within 7 days. Written report within 30 days to Transport Canada for TDG releases. TDG releases also require reporting to: the consignor of the dangerous goods; the owner, lessee or charterer of the road vehicle; and, for an accidental release from a cylinder that has suffered a catastrophic failure, CANUTEC at 613-996-6666.			B.C. Ministry of Environment, local police & TDG releases via the EMCR 1-800-663-3456 Oral report immediately to above. Written report may be required by the MOE. Written report within 30 days to Transport Canada for TDG releases. TDG releases also require reporting to: the consignor of the dangerous goods; the owner, lessee or charterer of the road vehicle; and, for an accidental release from a cylinder that has suffered a catastrophic failure, CANUTEC at 613-996-6666.		
Federally regulated releases	<ul style="list-style-type: none"> Report to Environment Canada 1-780-499-2432 for any release of a deleterious substance directly or indirectly (including through groundwater) into water frequented by fish. Canadian Energy Regulator (CER)-regulated pipelines require reporting to the CER 403-299-2773 for all construction and operation releases. Operation incidents must also be reported to the Transportation Safety Board of Canada (TSBC) 819- 997-7887. Radioactive releases must be immediately reported to any CNSC (Canadian Nuclear Safety Commission) office and a full report must be filed within 21 days. CNSC Western Regional Office 403-292-5181. 					
Notes:						
1	In Alberta: A release includes to spill, discharge, dispose of, spray, inject, inoculate, abandon, deposit, leak, seep, pour, emit, empty, throw, dump, place, and exhaust. To be reportable, the release must be into the environment. For example, a spill that is fully contained within a building, including odours, is not considered a release into the environment. However, if there is any possibility of odours venting from the building into the environment, AENV should be notified. All releases must be reported, regardless of a minimum reportable quantity, if the release has caused, is causing or may cause an adverse effect. An "adverse effect" is defined as "impairment of or damage to the environment, human health or safety, or property". All releases must be reported, regardless of a minimum quantity, if the release is into a watercourse, groundwater, or surface water. If there is any doubt, report the release.					
2	In B.C.: All releases must be reported, regardless of a minimum reportable quantity, if the release of a "polluting substance" is causing "pollution". A "polluting substance" is any substance, whether gaseous, liquid or solid, that is capable of causing pollution if it were to escapable to air, or be spilled or escape onto land or into a waterbody. "Pollution" is the presence in the environment of substances or contaminants that substantially alter or impair the usefulness of the environment. If there is any doubt, report the release.					
3	Transportation refers to the TDG and means all handling, offering for transport and transporting of dangerous goods by any means of transport. Handling means loading, unloading, packing, or unpacking dangerous goods in a means of containment for the purposes of, during, or following transportation, and includes storage during transportation. Transportation does not include pipelines.					
4	Contact your Environment Specialist. Classification (Waste/TDG) is variable. Refer to the product's SDS or the WPS to determine TDG classification; of note: amines and inhibitors can have a variety of classifications (e.g., corrosive, flammable, etc.).					
5	Additional AER immediate reporting requirements include: any fire that occurs at a well or facility, or at a storage tank or pit, where the loss exceeds 30,000 m ³ of natural gas or where damage to the wellhead occurs; any break or leak in a vessel or gathering line from which the loss exceeds 30,000 m ³ of natural gas; any unexplained loss, including theft of oil at a well or facility, where the loss exceeds 2 m ³ of oil, condensate or crude bitumen; any casing leak or failure; any leak or break in a pipeline; any leak in a pipeline during pressure testing.					

Uncontrolled when printed. The controlled copy is on the NRM EHS e-site. Rev. January 8, 2025

9.2 BRITISH COLUMBIA

9.2.1 Incident Classification and Reporting Requirements

Please refer to section 1.4 Situation Assessment for the British Columbia Incident Classification Matrix.

Classification: Consequence Levels

Consequence 0 – “No consequential impacts” – At this level, there are no reportable spills, no equipment damages, and no reason to interrupt normal operations.

Consequence 1 – At this level, there has been some minor effect on operations; a spill had to be cleaned, equipment fixed with a minor repair, etc. For a sour product spill, H₂S must be under 100 ppm at the source point of the spill with no detectable levels off lease. Total incurred costs are typically under \$50,000.

Consequence 2 – At this level impacts have become more pronounced; there may be some loss of production capability (temporary stoppages, reduced output, etc.) or the incident may have, or has the potential to extend off lease/beyond ROW. Any sour product of 100 ppm or greater must have a consequence level of 2 or more indicated due to the threat to workers, public or environment.

Consequence 3 – At this level impacts have had a noticeable effect on operational capabilities, affected public or environment, or have raised significant concerns for operational safety - such as malicious equipment tampering, or a pattern of failure in an equipment type or process.

Consequence 4 – At this level, operations would typically be suspended or impossible to continue, at least in the short term. Critical equipment would be damaged/destroyed.

Natural Gas Release

When a natural gas release exceeds 2,000 m³, or when the duration or total volume of the release is uncertain and may exceed this threshold, a minimum Consequence Level 2 must be selected. Escaping gas that migrates off lease automatically triggers a Consequence Level 2 or higher classification.

For sour gas releases:

- Any measurement of ≥ 10 ppm H₂S at 1 meter from the leak source is a reportable incident, and protective actions must be initiated to prevent public access.
- Any sour product with ≥ 100 ppm H₂S requires a Consequence Level 2 or greater, due to increased risk to workers, the public, and the environment.

Well Kicks

A well kick size in excess of 3 cubic meters OR shut-in casing pressure in excess of 1000 kpa requires a consequence level 2.

If conditions indicate an increased risk to well control (e.g., sustained pressure increase, escalating gas influx, equipment impairment, or loss of primary barriers), the consequence ranking may be escalated at the Company's discretion, in accordance with internal risk processes.

Security Incidents

Security events are classified based on operational impacts: Theft, vandalism, or tampering that interrupts operations generally result in Consequence Level 1 or higher. A credible threat that *requires* shutting in a well or facility, significantly enhancing security, restricting normal operations

Classification: Probability Level

Probability 0 – “Will not escalate; no hazard; no monitoring required” – This level is typical of a fixed quantity spill that is completely contained by a berm or impoundment, or able to be immediately remediated. A probability of zero can not be assigned if the source of the spill has not been controlled, accurately identified, or the extent of the spill fully defined. Spills to water are highly unlikely to ever have a probability of zero given the likelihood of spill migration and impacts.

Probability 1 – “Escalation highly unlikely; controlled or imminent control” - Small equipment failures that are easily isolated would be rated at this level. Turning off power or closing valves to/from the equipment bring the incident under control, with very little possibility of further damage or release of product.

Probability 2 – “Escalation unlikely; controlled or likely imminent control” - This level is typical of incidents where the cause of the incident is easily determined, and control measures are able to be enacted promptly and successfully.

Probability 3 – “Escalation possible; under or imminent control” - Pit gains of 10 m³ or greater during a drilling operation, or a fire on site that was of limited scope – such as a fire in a holding tank or generator shack would normally be ranked as a Probability 3. Additional considerations in this example would be the potential for expansion such as to other nearby equipment or forested areas, or possible need for an evacuation of a public area or residents. Repeating, related or similar security incidents, such as ongoing vandalism targeting a particular site or type of operation would use this probability level.

Probability 4 – “Uncontrolled, with control unlikely in near term” - An equipment failure that has caused uncontrolled release of product beyond the ability of the operator to control – such as a facility explosion, a pipeline rupture with uncontained product moving into the environment, or a fire that is spreading/growing without possible containment with the resources at hand would all be classified as Probability 4.

BCER Incident Reporting Guidelines

Minor Incident

- Those with a total score of two or less on the Classification Matrix, permit holders are responsible for directly entering information into the Regulator’s on-line reporting system, CM-IS (Compliance Management Information System), within 24-hours of the incident.
- If the minor incident involves a leak or a spill, EMCR must also be called for the Ministry of Environment & Climate Change Strategy to be notified.
- The incident must be reported by electronic submission by the permit holder incident representative. A copy of the Form A: Minor Incident Notification Form and the Incident Classification Matrix can be found on the Emergency Response and Safety section of the Regulator’s website to help the permit holder gather the information required before entering it online. The matrix and any photos or any other relevant documentation can be attached to the online submission.

Level 1, 2, or 3 Emergency

If the incident receives a score of Level 1, 2, or 3, it must be reported immediately (within 1 hour) to the BCER by calling EMCR’s incident reporting line.

For incidents that involve the release of a reportable volume/product – as defined under the Spill Reporting Regulation – a Dangerous Goods Incident Report (DGIR) must be obtained from EMCR.

Note that incidents involving a form of transportation (truck or rail) also have reporting requirements under federal Transportation of Dangerous Goods (TDG) regulations, and some products have significantly smaller reportable thresholds.

When a sour gas product is released, any measurement of 10 ppm or greater measured at 1 meter from the source of the leak requires reporting as an incident. Protective actions to prevent public access must be taken. This requirement applies to leaks from any source, including surface casing vent assemblies.

A release of any product into moving water is considered to be an off-lease/right of way spill.

Incidents scoring 3 or higher are classified as emergencies and are reported through EMCR. The Regulator’s duty emergency officer will be notified by EMCR and will directly contact the permit holder (or representative) who has assumed the on-scene incident commander role. A DGIR is also obtained if there is release of product.

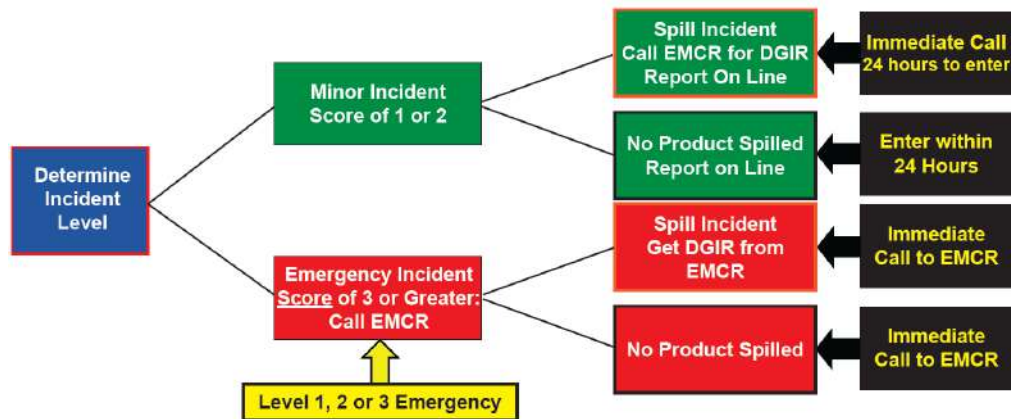

Permit Holder Post-Incident Report

Effective April 10, 2025, all incident reporting to the BC Energy Regulator must be completed through the Compliance Management Information System (CM-IS). This replaces previous reporting tools including Form D and KERMIT. Permit holders must report incidents directly in CM-IS, using the online data entry forms and integrated communication tools. PDF uploads are no longer accepted for post-incident reviews. Users must have an Online Systems account with appropriate permissions to access CM-IS.

For a Summary of Reporting Workflow in CM-IS please see the B.C. Incident Notification Process (CM-IS) within section 10.2.1 British Columbia Forms.

Induced Seismicity

Seismic events recorded within 3 km of any injection activity require specific actions depending on the event’s magnitude.

If the magnitude of the seismic event is equal to or greater M4 and linked to an injection operation, all injection activities must immediately suspend. If there is no damage caused or expected, the BCER can be notified through the complaints line (1-877-500-2237) and a minor report must be submitted.

If damage is caused or suspected, on or off of the activity site, the Company must contact EMCR immediately through the 24-hour reporting line (1-800-663-3456) and a minor incident report must be submitted.

If a seismic event is felt or suspected but is less than M4, there are no immediate changes required to injection activities and the BCER must be notified to seismicmonitoring@bc-er.ca.

If the event occurred due to multi-stage, hydraulic fracturing in a horizontal well bore targeting the Montney Formation within the KSMMA or targeting the Montney or Doig Formations within the NMSMMA, please review the specific reporting requirements in the [BCER Induced Seismicity Operational Manual](#).

Other Reportable Incidents

The BCER’s Incident Risk Classification Matrix is designed to assist permit holders in determining which incidents must be reported. However, some incidents, which do occur, may not meet the criteria outlined in the Incident Risk Classification Matrix but still require notification to the BCER as a minor notification.

These include the following:

- Spills or release of hazardous substances which are not provincially regulated, such as radioactive substances.
- Major damage to oil and gas roads or road structures.
- Pipeline incidents, such as spills during construction phase, exposed pipeline
- Security related issues which are relatively minor; such information may be required for tracking and monitoring purposes only.

Downgrading the Emergency Levels and Stand-Down

Any discussions regarding downgrading of the incident Emergency Level classification must be preceded by a thorough review of the following considerations:

- Has the release been stopped?
- Is the hazard mitigated?
- Have all public safety threats been eliminated?
- Are there any remaining risks that could escalate if the Emergency Level was downgraded?
- Has an appropriate environmental monitoring plan been initiated (surface water, groundwater, soils, wildlife, vegetation, air quality monitoring)?
- Has environmental data been collected, analyzed and is it available to be submitted to the Regulatory Authority?
- Has an environmental mitigation plan been developed based on the data collected and has it been evaluated relative to potential residual impacts?

If the Incident Commander and CEOC Director agree that the emergency level, dictated by the Incident Classification Matrix, no longer reflects the current conditions and incident progression, the Company may proceed with downgrading the emergency to the appropriate level. The Regulatory Authority will note the incident level at its most critical state to keep for their internal records.

Once site restoration is deemed appropriate and incident facts justify transitioning from a state of readiness or alert, the Company must make the decision to stand down the emergency. Following this decision, the Company will consult with the Regulatory Authority to communicate the change and ensure alignment on next steps.

The Company must keep all notified stakeholders and evacuated people informed of the status of an emergency.

BCER Emergency and Incident Response Flowchart

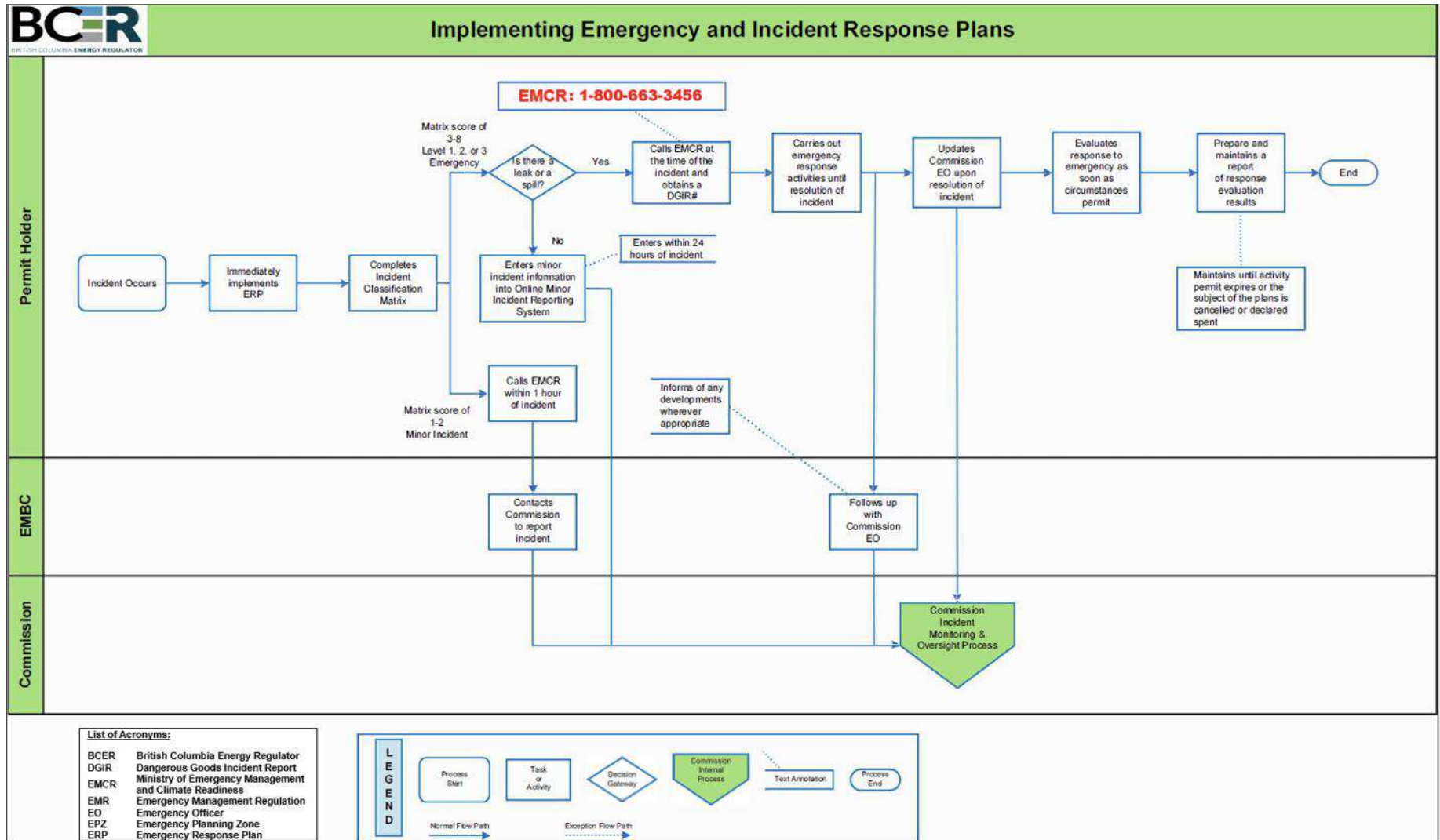

9.2.2 Spill Reporting

For land-based spills during daytime operations, responses must be initiated within six (6) hours from the time spill is discovered.

For spills occurring on weekends or during the night, responses must be initiated within twelve (12) hours from time of discovery.

As per the Environmental Management Act, all spills (including type, size and location) must be reported immediately to the Ministry of Emergency Management and Climate Readiness (EMCR).

Notification Requirements

The person who had possession, charge or control of a substance immediately before it is spilled shall immediately report to EMCR or when not practical to the local police or RCMP. He/she shall take all reasonable and practical action and have due regard for the safety of the public to stop, contain and minimize the effects of the spill.

A report under this section must include, to the extent practicable, the following information:

- a) the contact information for
 - i) the individual making the report,
 - ii) the responsible person in relation to the spill, and
 - iii) the owner of the substance spilled;
- b) the date and time of the spill;
- c) the location of the spill site;
- d) a description of the spill site and the surrounding area;
- e) a description of the source of the spill;
- f) the type and quantity of the substance spilled;
- g) a description of the circumstances, cause and adverse effects of the spill;
- h) details of action taken or proposed to comply with section 91.2 (2) [responsible persons - spill response 1 of the Act;
- i) the names of the government, federal government, local government and first nation government agencies at the spill site;
- j) the names of other persons or government, federal government, local government or first nation government agencies advised about the spill.

BC Environmental Management Act; Spill Reporting Regulation

BCER Spill Reporting Criteria

Where the permit holder holds or maintains rights, the permit holder must report to the British Columbia Energy Regulator, all spills of materials as identified below:

Release Reporting Requirements – British Columbia

Common Unrefined Product Releases

Substance/Example	BC (BCER/EMCR) Reporting Requirements	TDG Reporting Requirements Road, Rail or Marine
Any release of a “polluting substance” be it gaseous, liquid, or solid, that causes “pollution”.	Any amounts. If there is any doubt, report the release.	No specific TDG reporting requirements.
Any spill or release that enters, or is likely to enter, or impact a body of water ^{†††}	Any amounts. If there is any doubt, report the release.	No specific TDG reporting requirements.
Any fluid with toxic substances (BC Only) *	25 L	No specific TDG reporting requirements.
Hydraulic Oil	200kg or 200 L	No specific TDG reporting requirements.
Methanol	100 L	See Class 3 and 6.1
Natural Gas	10 kg, there is a break in a pipeline or fitting operated above 100 psi that results in a sudden and uncontrollable release of natural gas	See Class 2.1
Crude Oil/Emulsion	100 L	See Class 3
Produced/Saltwater	200 L	No TDG requirements.
Drilling or Invert Mud	100 L, unless it contains toxic substances, then 25 L.	
Condensate	25 L	
Used Glycol (BTEX Content)	10,000 L	No TDG requirements.
Fresh Water (BC Only)	100 L	No TDG requirements.
If there are any doubts on the reporting requirements for a spill or release, report it.		

*Any fluid including hydrocarbons, drilling fluids, invert mud, effluent, emulsions, etc. which contain toxic substances (BC only).

†††Body of water as defined in section 1 of the Spill Reporting Regulation

TDG and Provincial Reportable Releases of Common Products at Energy Sites

Chemical Class	Substance/Example	BC (BCER/EMCR) Reporting Requirements	TDG Reporting Requirements Road, Rail or Marine
Class 1 Explosives	Ammunition Nitro-glycerine	50 kg, or less if the substance poses a danger to public safety.	Any quantity of Packing Group II.
Class 2.1 Flammable Gases	H ₂ S Methane Propane Butane	10 kg	Any quantity.
	Natural Gas	10 kg, if there is a breakage in a pipeline or fitting operated above 100 psi that results in a sudden and uncontrolled release of natural gas	
Class 2.2 Non-Flammable and Non-Toxic Gases	Compressed Air O ₂ N ₂ CO ₂	10 kg	
Class 2.3 Toxic Gases (Poisonous or Corrosive)	SO ₂ Anhydrous Ammonia Carbon Monoxide	5 kg	
Class 3 Flammable Liquids	Demulsifiers† Diesel Gasoline Methanol† – use UN # to determine subclasses Scale Inhibitors†	100 L	Any quantity of Packing Group I or II.
Class 4 Flammable Solids	Activated Carbon Calcium Carbide Molten Sulphur Sodium	25 kg	
Class 5.1 Oxidizing Substances	Calcium Nitrate Ammonium Nitrate Bleaches	50 kg or 50 L	
Class 5.2 Organic Peroxides	Peroxide	1 kg or 1 L	
Class 6.1 Poisonous Toxic Substances	Methanol Arsenic Hydrogen Cyanide Lead Acetate Mercuric Chloride Pesticides†	5 kg or 5 L	More than 30 L or 30 kg of Packing Group III or without Packing Group.
Class 6.2 Infectious Substances	Infectious substances affecting humans/animals.	1 kg or 1 L, or less if the waste poses a danger to public safety or the environment	
Class 7 Radioactive Materials	Uranium Plutonium Naturally Occurring Radioactive Materials (NORM)	Any quantity that could pose a danger to public safety and an emission level greater than the emission level established in section 20 of the "Packaging and Transport of Nuclear Substances Regulations", 2015 (Canada)	For packages being transported under exclusive use: (i) 10 mSv/h on the external surface of the package(ii) 2 mSv/h on the surface of the conveyance, and (iii) 0.1 mSv/h at a distance of 2 m from the surface of the conveyance. For packages not being transported under exclusive use: (i) 2 mSv/h on the external surface (ii) 0.1 mSv/h at a distance of 1 m from the package, (iii) 2 mSv/h on the surface of the conveyance, and (iv) 0.1 mSv/h at a distance of 2 m from the surface of the conveyance.
Class 8 Corrosives	Acids† Amines† Bases† Batteries† Caustics† Nitric Acid	5 kg or 5 L	Any quantity of Packing Group I or II. More than 30 L or 30 kg of Packing Group III or without Packing Group.
Class 9 Miscellaneous Products, Substances or Organisms (Environmentally Hazardous Substances)	PCB Asbestos Polystyrene Beads Gas Plant Filters Benzoic Acid Chromic Acetate Cupric Sulphate Lithium Batteries	25 kg or 25 L	30 L or 30 kg of Packing Group II or III, or without Packing Group.
Waste Containing Dioxin^{††}		1 kg or 1 L, or less if the waste poses a danger to public safety or the environment	
Leachable Toxic Waste^{††}		25 kg or 25 L	
Waste Containing: Polycyclic Aromatic Hydrocarbons^{††}		5 kg or 5 L	
Waste Asbestos^{††}		50 kg	
Waste Oil^{††}		100 L	
Waste Containing: A Pest Control Product^{††}		5 kg or 5 L	
PCB Wastes^{††}		25 kg or 25 L	
Waste Containing: Tetrachloroethylene^{††}		50 kg or 50 L	
Biomedical Waste^{††}		1 kg or 1 L, or less if the waste poses a danger to public safety or the environment	
A Hazardous Waste^{††} Any substance not covered by the above.		25 kg or 25 L	
Other (Any substance not covered by the above, that can cause pollution).		200 kg or 200 L	
Natural Gas		10 kg	

Chemical Class	Substance/Example	BC (BCER/EMCR) Reporting Requirements	TDG Reporting Requirements Road, Rail or Marine
Items listed above if spilled to a body of water ^{†††}		Any quantity	

[†] Product names that are commonly used to refer to a number of products that have various classifications. Refer to the product's SDS to confirm TDG classification.

^{††} As defined in section 1 of the Hazardous Waste Regulation

^{†††} Body of water as defined in section 1 of the Spill Reporting Regulation and the Spill Reporting Fact Sheet (June 2024).

Packing Group I: great danger and most protective packing required. Some combinations of different classes of dangerous goods on the same vehicle or in the same container are forbidden if one of the goods is Group I.

Packing Group II: medium danger.

Packing Group III: minor danger among regulated goods and least protective packaging within the transportation requirement.

9.2.3 *Emergency Planning and Response Zones*

Under Emergency Management Regulation in British Columbia EPZs are required for all sour gas facilities and EPZs are required for all other significant hazards.

The principle hazards associated with a hydrocarbon release are:

- Exposure to the toxicity of H₂S following an unignited sour gas release.
- Exposure to the toxicity of SO₂ following an ignited sour gas release.
- Exposure to flame for people located within a flammable region of a dispersing gas plume following delayed ignition of a release.
- Heat radiation from a fire following ignition of a release.

To determine the size of the response zones, response personnel should approach the perimeter of the response zone cautiously so as not to exceed the ceiling exposure limits and begin monitoring with handheld equipment at the nearest residence. Note that the ceiling H₂S exposure limit in British Columbia is 10 ppm.

From this location, the response personnel should continue to approach any additional downwind residences that may be closer to the release until the outer boundary of the response zone is determined.

Various factors will determine the extent of the EPZ:

- The nature of the product released.
- The volume released.
- The product flow rate.
- Weather or meteorological conditions.
- Topography.

Whereas the EPZ is used for planning purposes and it reflects an area where significant exposure could result without prompt action, actual conditions during an incident need to be assessed to ensure an appropriate initial response. The response zones are where resources are focused during an incident to protect public safety. A licensee should also be aware that a different type and size of response zone could be established by the police if a bomb has been confirmed at the pipeline, well, or facility.

Emergency Planning Zone (EPZ)

British Columbia Energy Regulator defines an EPZ as a geographical area surrounding a well, pipeline, or facility containing hazardous product (H₂S or SO₂) that requires specific emergency response planning by the licensee. The Emergency Planning Zone may also be referred to as Hazard Planning Zone or HPZ.

Existing wells and pipelines are assessed annually to ensure the H₂S release volume calculations are based on actual operating and licensed conditions.

Emergency Awareness Zone (EAZ)

The Emergency Awareness Zone (EAZ) is an area twice the radius of the Emergency Planning Zone.

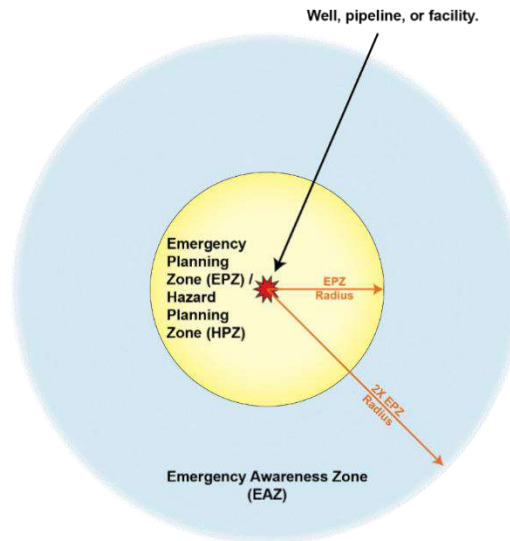

9.2.4 Methods of Public Protection

If the health and safety of the public cannot be assured, then the Company must determine the best approach for protecting the public. Depending on the severity of the emergency, the Company will implement one of three approaches to public protection: sheltering, evacuation, or ignition.

The purpose of public protection measures is to proactively address public health and safety concerns and to take appropriate response actions to protect the public from harm. This may include removing or reducing the hazards and asking public stakeholders to shelter and/or evacuate as required.

It is the Company's responsibility to initiate public protection measures in the EPZ for any incident involving a release of sour gas product if there is potential for the release to impact members of the public. This could also include SO₂ if the sour gas release was ignited.

The type of public protection measure employed depends on the severity of the incident and/or on the monitored results in the unevacuated areas. The licensee is responsible for ensuring that appropriate emergency response procedures are in place and can be implemented, including for areas of potential impact beyond the EPZ.

Affected Parties within a Predetermined EPZ

- Permanent and part-time residents, including those residing on dead-end roads, beyond a predetermined EPZ, where occupants are required to egress through the EPZ.
- Business owners and/or operators and industrial operators, including oil and gas operators with manned facilities inside a predetermined EPZ.
- Private and public recreational property owners and/or operators (e.g. campgrounds, trapper cabin, private cabins, etc.) in and adjacent to a predetermined EPZ.
- Public facilities and publicly used development, such as schools and community centres in or adjacent to a predetermined EPZ.
- Non-resident landowners or farmers renting land who do not dwell on the property but whose lands are within a predetermined EPZ. These persons must be considered in the development of the ERP and be advised their property lies within the EPZ.
- First Nation reserves, registered trappers, guides, outfitters, and registered grazing lease rights holders or any other rights holders if the EPZ impacts the safety or livelihood of these stakeholders.
- Oil and gas operators with unmanned assets (e.g. wells, pipelines, facilities, etc.) in a predetermined EPZ whose activities may be impacted in the event of an emergency.

Procedures for contacting affected parties within the EPZ

Well Operations: Ensure the Wellsite Supervisor or delegate notifies residents, landowners/land-renters and rights holders inside the EPZ:

- At the beginning of drilling and initial completion operations.
- 24-hours before entering the sour zone.
- At the conclusion of drilling and initial completion operations.
- At the beginning and conclusion of other operations, including workovers, flaring, fracking, etc.

Production Operations: Ensure the Field Foreman or his delegate notifies all applicable stakeholders prior to the commencement and conclusion of any high-risk operations.

Refer to the Supplemental ERP - Field Specific Response Actions - for site-specific procedures regarding contacting and communicating with affected parties within the EPZ.

Public Safety Decision Process

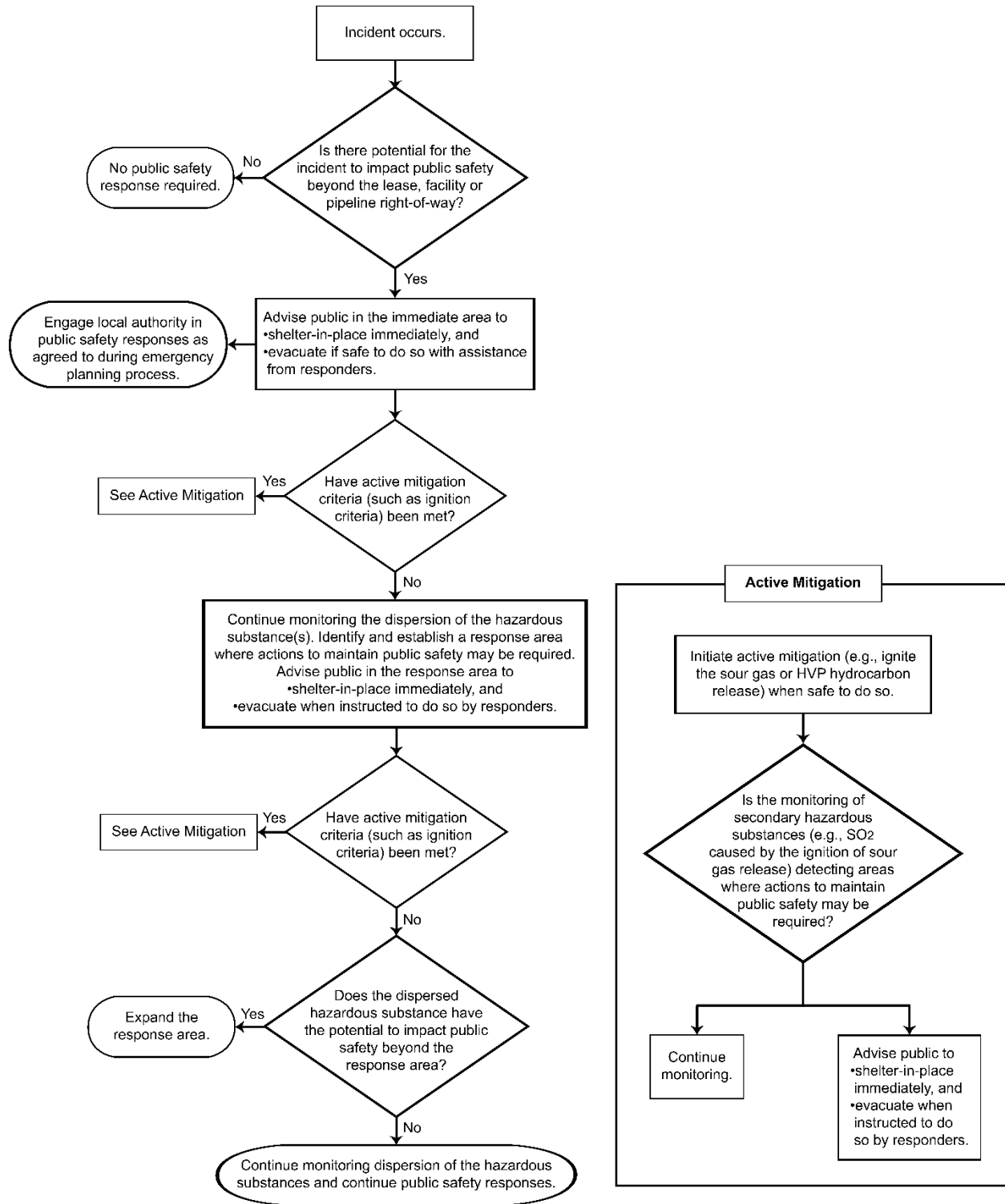

Sheltering

Sheltering may be the safest and most viable public protection measure in avoiding exposure to toxic or combustible gases in the following situation:

- Incident is of relatively short duration.
- Source of a release is uncertain.
- Residents are waiting for evacuation and transportation assistance.
- Not enough time is available to safely evacuate residents.
- Evacuation poses a higher risk to evacuees.

Residents will be asked to remain inside and ensure that all windows and doors are closed and that all air intakes (furnace, stove, bathroom, and dryer vents) are plugged to limit exposure to outside air until the situation is rectified or they are further notified.

Note: For general Shelter in Place Instructions, refer the Response Action Plans Section in this document.

Evacuation

Safe evacuation is the primary public protection measure for long term H₂S, SO₂, or other toxic releases.

Evacuation of occupants inside the defined EPZ shall be prioritized in the following manner:

1. Individuals located immediately downwind or adjacent to the incident site.
2. Individuals who have indicated they have special needs or require assistance.
3. Individuals who cannot be contacted by telephone.

Voluntary Evacuation

For a Level 1 Emergency, residents within the EPZ will be notified and given the Voluntary Evacuation Message.

The decision to proceed with this initial notification will be made by the Incident Commander after careful consideration to ensure residents are not unnecessarily stressed.

Should area users be affected by an emergency involving Company operations, the response personnel will notify stakeholders by telephone or by personal contact with Rovers. A notice of evacuation is also placed on any unattended vehicles in the evacuation area and on doors of residences who are not home and cannot be contacted by phone.

Note: Individuals who have been identified as having special needs should be treated with priority and may choose to evacuate an area at an earlier time than other residents. These individuals may be highly responsive or sensitive to H₂S or other toxic gases.

Urgent Evacuation/Shelter

For a Level 2 Emergency or Level 3 Emergency, residents inside the EPZ will be notified and given the **Shelter in Place** or **Urgent Evacuation Message**. The Company must provide for air monitoring at the nearest downwind unevacuated residence.

Evacuation Outside of the EPZ

The evacuation of the public outside of the EPZ may be required if the incident cannot be controlled and/or H₂S, SO₂, or other toxic releases concentrations reach the maximum allowable limits adjacent to the EPZ boundary. In the unlikely event that public protection measures are required beyond the EPZ, they will be conducted in accordance with the licensee's arrangement with the local authority.

The Company shall provide the necessary personnel and equipment deemed necessary to assist. The BCER shall be available for assistance if required.

Mandatory public safety response criteria

H₂S concentrations in non-evacuated areas	Requirement
Above 10 ppm (3-minute average) *, or above 1 ppm (1-hour average) in an urban centre	Carry out immediate shelter-in-place and/or evacuate all persons in the area and ignite the release if the criteria are met.
* If monitored levels in successive three-minute intervals are declining and shelter-in-place is occurring, evacuation may not be necessary. Operators should consult with the regulatory authority (if applicable) and use proper judgment in determining if evacuation is required.	
SO₂ concentrations in non-evacuated areas	Requirement
Above 5 ppm (15-minute average), above 1 ppm (3-hour average), or above 0.3 ppm (24-hour average)	Carry out immediate shelter-in-place and/or evacuate all persons in the area.
Ignition Assessment Criteria and Flowchart	

The evacuation area will be expanded in areas where monitored H₂S and/or SO₂ concentrations exceed the evacuation levels and/or resident health effects are apparent. If an uncontrolled release is ignited to protect the public, continuous monitoring for SO₂ or H₂S of the surrounding area would determine if public evacuation becomes necessary.

Company personnel cannot force a resident to evacuate their residence. Forced evacuation is possible only if the local authority declares a local State of Emergency under the Provincial ERP.

Ignition

If an immediate threat to human life exists and there is not sufficient time for consultation, the Incident Commander (IC) or designated Permit Holder Representative is authorized to ignite the release. This decision to ignite will be fully supported by Management. When time permits, the decision to ignite will be made jointly with the Incident Commander, CEOC Director, and the BCER Representative. If not, Notify the BCER immediately upon ignition decision and confirmation of ignition.

It is important that mobile air-quality monitoring be dispatched as quickly as possible to the emergency site, as specialized monitoring equipment can accurately record readings in the emergency area. The mobile air-quality unit must be equipped to continuously measure and record wind speed and direction and to monitor H₂S and SO₂ to parts per billion (ppb). Permit holder personnel will monitor and record the air until a mobile air-monitoring unit arrives or until the incident is over. At a minimum, these readings must include LEL and H₂S.

Pre-Ignition Checklist

Pre-ignition planning shall use the hazard assessment and EPZ data from the ERP to confirm plume and perimeter boundaries. Prior to ignition, the following safeguards and verifications must be completed and documented:

1. Plume location identified and hazard perimeter established.
2. Public within the hazard area evacuated or protected (shelter-in-place as directed).
3. Wind direction verified and the ignition approach confirmed from an upwind position.
4. Measures in place to prevent unplanned ignition, including control of ignition sources, hot work, and traffic.

Ignition Decision Considerations

The following factors should be considered before the decision to ignite proceeds:

- Safety and health risks to emergency personnel;
- Proximity of release to public areas;
- Availability of air monitoring equipment and personnel;
- Availability of ignition equipment, and training of staff in its use;
- Availability of trained and competent personnel as defined by CSA Z246.2 and IRP-2
- Detectable concentration of H₂S and/or flammable gases near the source of the release and within the Emergency Planning Zone;
- Weather conditions;
- Duration of the release and potential volume;
- Impacts to wildlife; and
- Impacts to other values at risk including property, timber, or infrastructure.

All sour wells must have an ignition system such as a flare gun on site during all drilling, completion, well testing, or workover operations in the sour zone.

Company personnel are required to ensure that all special sour wells have a dual ignition system on site during all drilling operations in the critical zone(s) and during all completions, well testing, or work-over operations when the wellhead is off. The primary ignition system should be installed such that remote activation can be achieved from a safe location through a triggering device. The secondary system may be a manual system, such as a flare gun.

Post-Ignition Monitoring and Control

- Coordinate public information and notifications through the CEOC and BCER as required
- Continue continuous air monitoring for H₂S (incomplete combustion) and SO₂ (combustion by-product);
- Resize hazard zones for heat radiation and combustion products;
- Maintain and adjust roadblocks and public protection measures based on monitoring results;
- Reignite immediately if a flameout occurs and hazards persist;
- Coordinate ongoing monitoring and safety actions with BCER and local authorities;
- Record all air-quality data and operational actions on applicable ICS/CEOC forms to support incident downgrading and public-safety reassessment.

Documentation and Review

All ignition decisions, including timing, notifications made to BCER/agencies/stakeholder, decisions made, criteria, and monitoring results, must be documented and retained for post-incident review. Lessons learned shall be incorporated into future ERP updates and training exercises to ensure continual improvement.

Training records and competency verifications for ignition personnel shall be maintained in accordance with CSA Z246.2 Clause 5.3.

References

Developed in accordance with the BC Energy Regulator Core ERP Content Checklist Guidance (Version 1.1, November 2023), the Emergency Management Regulation (B.C. Reg. 217/2017), and CSA Z246.2 - Emergency Preparedness and Response for the Petroleum and Natural Gas Industry Systems. Any numeric thresholds included are company-specific criteria to support timely decision-making and are not BCER-mandated.

For sour operations, ignition systems and procedures must also align with Energy Safety Canada IRP-2 requirements for remotely operated primary ignition systems and secondary backup systems during critical operations.

Ignition Assessment Criteria and Flowchart

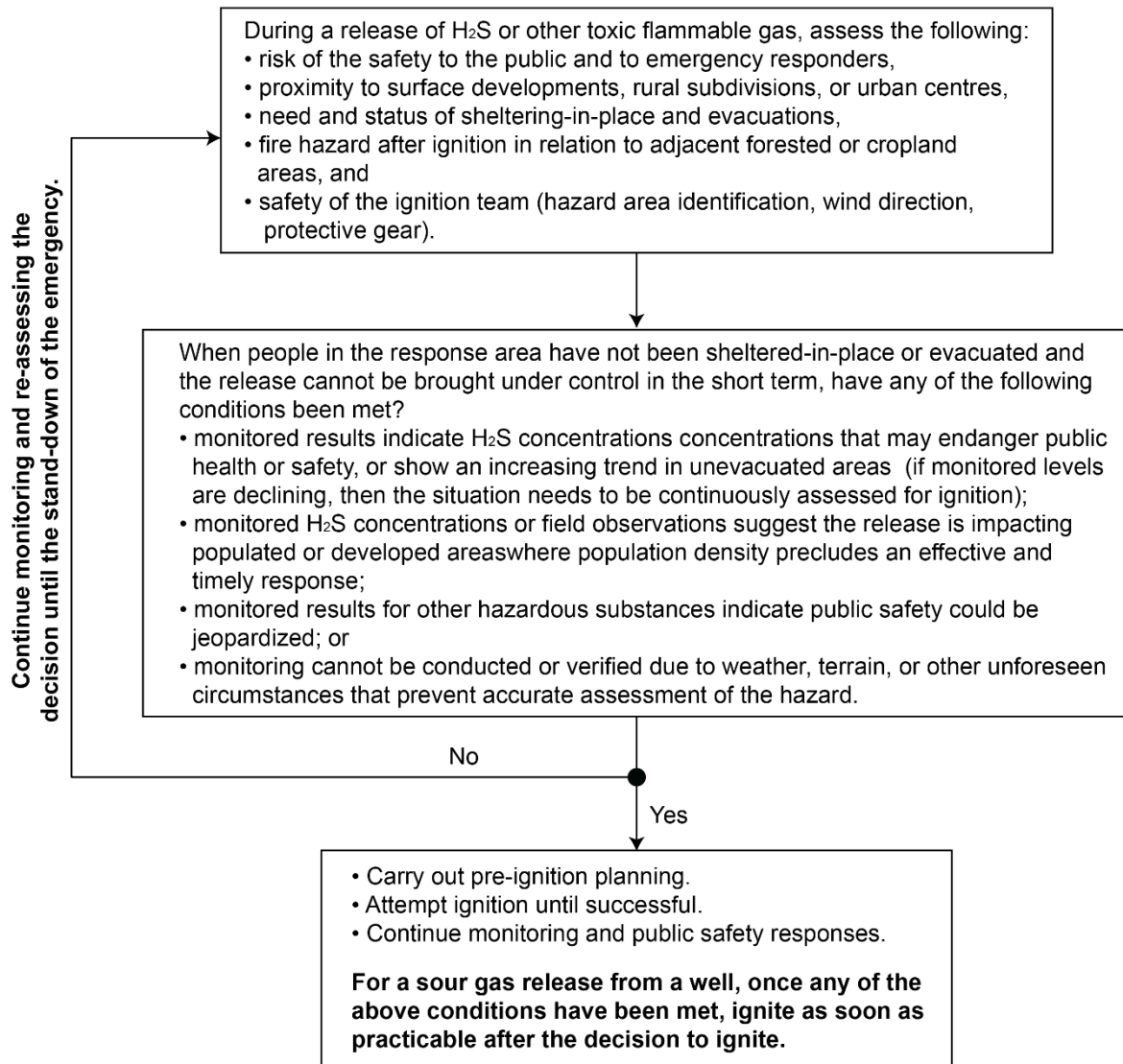

Ignition Procedures Flowchart

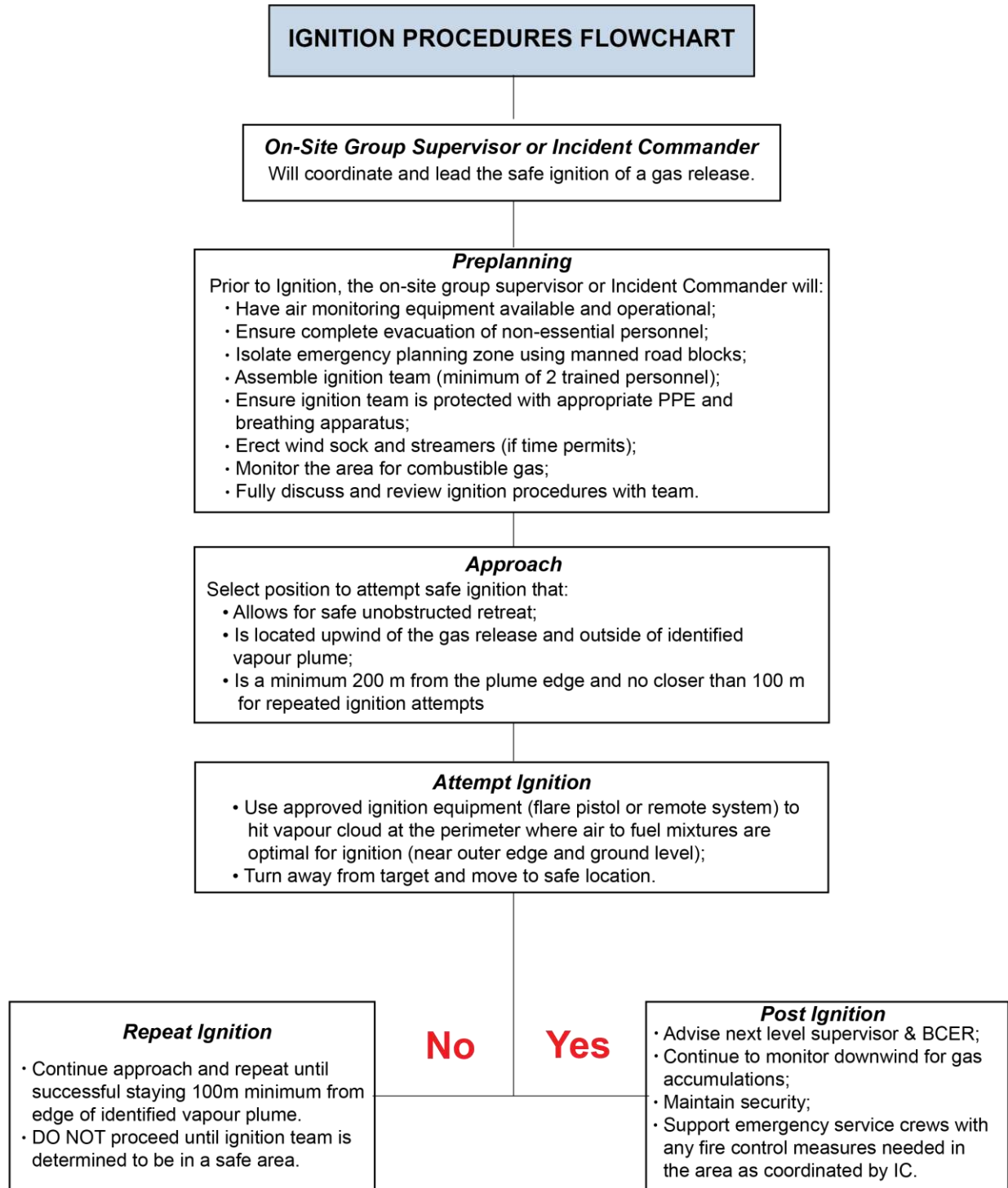

9.2.5 Closure Orders

Notice to Airmen (NOTAM)

In an emergency situation requiring isolation of the response zones, contact the BCER to discuss the issuance of a Closure Order.

It may be necessary to obtain a closure order (if issued by the BCER) or to declare a local state of emergency to restrict access to a designated area. A local state of emergency may be declared by the local authority should the incident escalate beyond the defined EPZ.

It also may be necessary for NAV Canada to issue a Notice to Airmen (NOTAM) to advise pilots of restrictions in the airspace above the EPZ or to close the airspace for a certain radius from the release (a no-fly zone). NOTAMs or closure of airspace may be required by the BCER at a level 2 or 3 emergency.

Oil and Gas Road Closures

In Emergencies, permit holders must phone the BCER's 24-hour Incident Reporting line to notify the BCER of needed emergency oil and gas road closures. Under Section 20 of the OGRR a permit holder may temporarily close or restrict access if the action is necessary to address an existing or imminent threat to the environment or human life.

Under such circumstances, the Permit Holder must promptly notify the BCER. The notices of closure and resumption must be submitted to the Regulator by email to BCER.

Closure Order	Agency
Petroleum Development Road (PDR)	BC Energy Regulator (BCER)
Forestry Roads (rights-of-ways)	Ministry of Forests, Lands, Natural Resources Operations and Rural Development (FLNRORD) or Forest Service Road Maintenance Contractor
Numbered Highway (rights-of-ways)	Ministry of Transportation & Transit (MOTT)

*Ministry of Forestry is not to be involved in road closure notifications.

9.2.6 Government Roles and Responsibilities

Provincial Regional Emergency Operations Centre (PREOC)

The Provincial Regional Emergency Operations Centre manages activities at the Provincial Regional Coordination Level and coordinates the joint efforts of government and non-government agencies.

If the situation escalated beyond BCER control, EMCR may establish a Provincial Regional Emergency Operations Centre (PREOC) near the emergency site to coordinate provincial response. The PREOC also keeps elected provincial officials informed through personal contacts and briefing notes.

British Columbia Energy Regulator (BCER)

The BC Energy Regulator (BCER) plays a critical role in regulating energy activities in British Columbia, ensuring public safety and environmental protection throughout the full life cycle of energy resource activities. During a permit holder emergency, the BCER oversees the permit holder’s response, ensures compliance with provincial legislation, and supports the safe management of energy resources.

In an emergency, the BCER would be notified by EMCR, however, as EMCR works on a priority basis, the Company should take action and contact the BCER personally.

BRITISH COLUMBIA ENERGY REGULATOR	
<input type="checkbox"/>	Establish communication with the permit holder.
<input type="checkbox"/>	Confirm the incident level with the permit holder.
<input type="checkbox"/>	Oversee the permit holder’s response to the incident.
<input type="checkbox"/>	Deploy BCER representative(s) to one or more of the permit holder’s command posts/sites.
<input type="checkbox"/>	Activate a government emergency operations centre (EOC) at the BCER office.
<input type="checkbox"/>	Confirm stand down of the emergency.
Additionally, BCER staff may take the following actions, as necessary:	
<input type="checkbox"/>	Confirm the ignition decision with the operator, if time permits.
<input type="checkbox"/>	Confirm and coordinate media releases issued by the permit holder.
<input type="checkbox"/>	Issue orders to secure the incident site for investigation purposes.

BRITISH COLUMBIA ENERGY REGULATOR

Ministry of Emergency Management and Climate Readiness (EMCR)

Ministry of Emergency Management and Climate Readiness (EMCR) was formed to be the lead coordinating agency in the provincial government for all emergency management activities. EMCR provides executive coordination, strategic planning, and multi-agency facilitation and strives to develop effective working relationships in an increasingly complex emergency management environment.

EMCR works with local governments, First Nations, federal departments, industry, non-government organizations and volunteers to support the emergency management phases of mitigation/prevention, preparedness, response and recovery. Additionally, EMCR engages provincial, national and international partners to enhance collective emergency preparedness.

The EMCR acts as a 24-hour incident reporting line and initiates government notification fan-out by notifying the BCER, Ministry of Environment & Climate Change Strategy and Environment and Climate Change Canada.

Regional District

The local authority will usually participate in any emergency that impacts or threatens land or residents outside the confines of company property.

In B.C., if regional districts have not been granted the powers of a municipality under the Emergency Program Act, then EMCR is responsible for coordinating response activities.

REGIONAL DISTRICT		REGIONAL DISTRICT
<input type="checkbox"/>	Implement the rural municipality/regional district disaster or emergency plan.	
<input type="checkbox"/>	Provide local knowledge about conditions, resources, and the community.	
<input type="checkbox"/>	Assist with the establishment and administration of a Reception Centre if required.	
<input type="checkbox"/>	Ensure local emergency services are available to assist the emergency response team.	
<input type="checkbox"/>	Dispatch representative(s) to the BCER's Emergency Operations Centre (EOC), if established.	
<input type="checkbox"/>	Provide support to ensure notification of endangered area residents.	
<input type="checkbox"/>	Provide support to coordinate and deliver emergency social services to evacuated residents.	
<input type="checkbox"/>	If necessary, declare a State of Local Emergency and issue an evacuation Alert, Order and Rescind.	
<input type="checkbox"/>	Assist in a public information service (joint BCER, Industry, local government).	
<input type="checkbox"/>	Provide building re-entry procedures.	

Emergency Services: Police, EMS, and Fire Fighting

EMERGENCY SERVICES		EMERGENCY SERVICES
<input type="checkbox"/>	Understand the hazards associated with the petroleum facilities and operations within the area.	
<input type="checkbox"/>	Work with the operator to effectively prepare for a petroleum industry incident.	
<input type="checkbox"/>	Understand the response role when there is a private and public sector response.	
<input type="checkbox"/>	Train personnel to carry out their functions when there is an incident.	
<input type="checkbox"/>	Establish contact with the industrial operator.	
<input type="checkbox"/>	Prior to dispatching staff to scene, determine the hazards associated with the incident.	
<input type="checkbox"/>	Determine where roadblocks are established.	
<input type="checkbox"/>	Where applicable, maintain roadblocks as necessary.	
<input type="checkbox"/>	Determine the direction of approach to the incident.	
<input type="checkbox"/>	Determine if there are any injuries.	
<input type="checkbox"/>	Find out what response and public protection actions have been taken by the operator.	
<input type="checkbox"/>	Initiate public protection option, when necessary.	
<input type="checkbox"/>	Identify what resources are required and where they should be staged.	
<input type="checkbox"/>	Determine the location of the On-Site Command Post.	
<input type="checkbox"/>	Respond and assess emergency incident.	
<input type="checkbox"/>	Communicate to REOC and provide situation reports as required.	
<input type="checkbox"/>	Dispatch a representative to the REOC, when it is established to coordinate the response.	
<input type="checkbox"/>	Assist with fire protection, where applicable.	
<input type="checkbox"/>	Provide emergency medical assistance, as required.	
<input type="checkbox"/>	Compile response logs.	
<input type="checkbox"/>	Participate in municipal incident debriefing.	
<input type="checkbox"/>	Participate in multi-agency debriefings.	

Ministry of Transportation Transit

The British Columbia Ministry of Transportation and Transit is the British Columbia government ministry responsible for transport infrastructure and law.

The ministry is responsible for the planning of transportation networks, providing transportation services and infrastructure, developing and implementing transportation policies, and administering many transportation-related acts and regulations.

The Ministry of Transportation and Transit would assist with closures of any provincial road or highway.

MINISTRY OF TRANSPORTATION AND TRANSIT		TRANSPORTATION & TRANSIT
<input type="checkbox"/>	Maintain a 24-hour emergency contact number where resources can be accessed for a response related to Emergency Response Plans.	
<input type="checkbox"/>	Respond to Dangerous Goods transportation emergencies in British Columbia.	
<input type="checkbox"/>	Provide advice and assistance in procurement of roadblock equipment.	
<input type="checkbox"/>	Provide authorization/assistance for establishing road closures and emergency roadblocks.	
<input type="checkbox"/>	Manage transportation route closures.	
<input type="checkbox"/>	Provide assistance with the closure of provincial highways in the establishment of suitable detour routes.	
<input type="checkbox"/>	Work with the appropriate local authority to facilitate the restoration of roadways.	
<input type="checkbox"/>	Ensure that all requests and reports are completed.	

WorkSafeBC

WorkSafe BC requires that all serious incidents and accidents be immediately reported and investigated. WorkSafe BC also carries out workplace inspections and investigations of work-related injuries and fatalities.

Regulatory excerpt

Section 172 of the Workers Compensation Act states:

172 (1) An employer must immediately notify the Board of the occurrence of any accident that:

- a) Resulted in serious injury to or the death of a worker,
- b) Involved a major structural failure or collapse of a building, bridge, tower, crane, hoist, temporary construction support system or excavation,
- c) Involved the major release of a hazardous substance,
- c.1) Involved a fire or explosion that had a potential for causing serious injury to a worker, or
- d) Was an incident required by regulation to be reported.

POLICY

Section 172(1)(c) requires the employer to notify the Board of any accident that involved the major release of a hazardous substance.

A major release does not only mean a considerable quantity, or the peculiar nature of the release, such as a gas or volatile liquid, but, more importantly, the seriousness of the risk to the health of workers. Factors that determine the seriousness of the risk include the degree of preparedness of the employer to respond to the release, the necessity of working in close proximity to the release, the atmospheric conditions at the time of the release and the nature of the substance.

As a general guideline, a report would be expected when:

- The incident resulted in an injury that required immediate medical attention beyond the level of service provided by a first aid attendant, or injuries to several workers that require first aid.
- The incident resulted in a situation of continuing danger to workers, such as when the release of a chemical cannot be readily or quickly cleaned up.

Local Health Authority

LOCAL HEALTH AUTHORITY	
<input type="checkbox"/>	Act as a consultant to the Emergency Operations Centre.
<input type="checkbox"/>	Monitor health effects of the incident to ensure appropriate data is collected and investigated.
<input type="checkbox"/>	Provide health advice on health and safety levels for the more vulnerable residents, including those in health care or special care facilities.
<input type="checkbox"/>	Provide advice to the government on the existing or potential health effects of the incident.
<input type="checkbox"/>	Establish health and safety levels for the escaping contaminants.
<input type="checkbox"/>	Establish and operate trauma teams for emergency health services.
<input type="checkbox"/>	Monitor adverse effects/contamination of water systems.
<input type="checkbox"/>	Enforce and regulate Public Health Regulations.
<input type="checkbox"/>	Recommend further investigation or research after the event, if warranted.

**LOCAL HEALTH
AUTHORITY**

Ministry of Environment & Climate Change Strategy

The Ministry of Environment & Climate Change Strategy is responsible for ensuring sustainable development of the province's land, water, and resources while protecting environmental values.

In the event of an emergency, a ministry representative will provide regulatory oversight and monitor the situation to ensure that the responsible party is taking the appropriate actions.

The MOE may provide a representative to the Incident Command Centre and the BCER Emergency Operations Centre and/or the Provincial Regional Emergency Operations Centre (PREOC) on a 24-hour basis. In a larger scale incident, based on risk, additional ministry resources such as Incident Management Teams may be deployed to establish Unified Command and monitor, augment, or take over the response if the responsible party fails to take appropriate action as deemed necessary by the ministry representative or Provincial Incident Commander.

MINISTRY OF ENVIRONMENT & CLIMATE CHANGE STRATEGY	
<input type="checkbox"/>	Assist the responsible party to ensure that other required agencies and affected stakeholders are contacted.
<input type="checkbox"/>	Monitor all discharges to the land, atmosphere and all waterbodies.
<input type="checkbox"/>	Provide assistance with hazardous waste management.
<input type="checkbox"/>	Conduct sampling for monitoring and enforcement purposes.

MOE

B.C. Ministry of Forests, Lands, Natural Resource Operations & Rural Development

If a forest fire is associated with the incident, and a provincial emergency is declared, B.C. Ministry of Forests, Lands, Natural Resource Operations & Rural Development personnel will assist. The Ministry will provide assessment of potential damage and offer advice for remedial control in areas relating to renewable resources.

BC Government Communications & Public Engagement (GCPE)

BC GOVERNMENT COMMUNICATIONS & PUBLIC ENGAGEMENT	
<input type="checkbox"/> Maintain a team of trained Public Affairs personnel.	GCPE
<input type="checkbox"/> Confirm distribution of BCER messaging. Provide support as required.	
<input type="checkbox"/> Activate Crisis Communication Plan and Crisis Communications Response.	
<input type="checkbox"/> Advise EMCR if media boardroom will be required for media events.	
<input type="checkbox"/> Coordinate key messaging with the BCER.	

9.2.7 Technical Safety BC - Pressure Equipment

Technical Safety BC is an independent, self-funded organization mandated to oversee the safe installation and operation of technical systems and equipment.

How to Report Incidents and Hazards to Technical Safety BC.

For emergency assistance call 911 or your local police or fire department directly.

Incidents and hazards are to be reported to Technical Safety BC through their website.

Alternatively, you can call 1-866-566-7233 and follow the prompts to report an incident or hazard.

Note: voicemail and email messages made to Technical Safety BC employees concerning incidents and hazards are not considered to have been reported to Technical Safety BC as required by regulation.

Definitions

Incident: A failure of a regulated product, work or operation that causes:

- Damage to property, personal injury or death.
- Damage to safety features.

Note:

- Property damage or injury focuses on the impact that the failed equipment may have had outside the boundaries of the product, work or operation.
- Damage to safety features relates to failures where the damage:
 - is limited to the failed product, work or operation and,
 - does not render the product or activity inoperative and,
 - impairs the safety feature’s effectiveness.

Safety Feature: An aspect of a product’s design, installation, maintenance or operation that is intended to prevent people or property from being exposed to a hazard.

Hazard: A source of potential harm to persons or potential damage to property.

Duty holder: A person or company who is responsible for compliance because they either own regulated products or perform regulated work.

Reporting of Incidents to Technical Safety BC

The following duty holders are required to report all incidents to Technical Safety BC:

- Person in charge of a regulated product or regulated work.
- Owner of the regulated product.
- Permit holder.
- Person authorized to perform or performing regulated work.
- Person authorized to operate or operating a regulated product.
- An officer or employee of a utility.
- Owner of a plant (as defined in the regulations).

Only one incident report per incident is required.

Duty to Preserve Incident Site for Investigation

A person must not remove, disturb or interfere with anything in, on or about the place where the incident occurred except as necessary to rescue a person, prevent injury or to protect property unless directed by a safety officer or safety manager.

Reporting of Hazards to Technical Safety BC

Hazards are required to be prevented or immediately corrected by duty holders that are responsible for the regulated product, work or operation. Hazards must be immediately reported to Technical Safety BC when:

- It is not known that the hazard is being corrected by the duty holder, or
- The same or similar hazards have been repeatedly observed and are associated with the same duty holder.

When to Report Incidents and Hazards to Technical Safety BC

Incidents:

Unless otherwise indicated, all incidents are to be reported within the following timeframes:

- Incidents resulting in a moderate, major or fatal injury – immediately.
- Incidents resulting in moderate, major or severe damage – immediately.
- All other incidents – within 24-hours (or as soon as practicable).

Moderate injuries are those that, while serious, are considered unlikely to have a significant effect to long-term quality of life. Examples include single limb fractures, concussions, and/or disorientation.

Moderate damage is damage that results with controlled exposure to energy (i.e. electrical, thermal, mechanical) or the limited/controlled release of substances intended to be contained.

Hazards:

All hazards as described in the 'reporting of hazards' section above are to be reported to Technical Safety BC immediately.

What to Expect After Reporting an Incident or Hazard to Technical Safety BC

Technical Safety BC tracks and investigates incidents and hazards that are reported to inform awareness and prevention initiatives. Consequently, Technical Safety BC does not investigate all reported incidents and may not follow-up with a notification unless there is an intention to investigate.

Summaries of all reported incidents and completed investigations can be accessed via Technical Safety BC. Technical Safety BC protects the identity of persons who report or may be involved with incidents or hazards.

Unless otherwise indicated, duty holders are required to preserve the equipment, products and items involved in an incident. Technical Safety BC will contact duty holders within 24-hours of the next regular business day following the report of an incident if more information is required or an investigation is planned to occur.

For more information, refer to Technical Safety BC's website.

9.2.8 List of Abbreviations/Definitions

Acronym	Name
EAZ	Emergency Awareness Zone: The area twice the radius of the EPZ.
Local Authority	Regional District
EMCR	Ministry of Emergency Management and Climate Readiness
MOE	Ministry of Environment & Climate Change Strategy
BCER	British Columbia Energy Regulator
PAB	Public Affairs Bureau
PREOC	Provincial Regional Emergency Operations Centre:
Regulatory Authority	British Columbia Energy Regulator
Rights Holders	Refers to anyone holding a permit under section 15 or a licence under section 39 of the Land Act, under which the person is granted non-intensive occupation or use of the land; a forestry licence to cut, master licence to cut, road use permit, timber sales licence, tree farm licence or woodlot licence under the Forest Act; a grazing permit or grazing license under the Range Act; a guide outfitter's certificate or a registered trapline under the Wildlife Act; a mineral claim under the Mineral Tenure Act; or, a water licence or approval under the Water Act.

9.3 ALBERTA

9.3.1 *Levels of Emergency Definitions*

ALERT

An incident that can be handled on site by the licensee through normal operating procedures and is deemed to be a very low risk to members of the public.

LEVEL 1 EMERGENCY

There is no danger outside the licensee's property, there is no threat to the public, and there is minimal environmental impact. The situation can be handled entirely by licensee personnel. There will be immediate control of the hazard. There is little or no media interest.

LEVEL 2 EMERGENCY

There is no immediate danger outside the licensee's property or the right-of-way, but there is potential for the emergency to extend beyond the licensee's property. Outside agencies must be notified. Imminent control of the hazard is probable but there is a moderate threat to the public and/or the environment. There may be local and regional media interest in the event.

LEVEL 3 EMERGENCY

The safety of the public is in jeopardy from a major uncontrolled hazard. There are likely significant and ongoing environmental impacts. Immediate multi-agency municipal and provincial government involvement is required.

Downgrading the Emergency Levels and Stand-Down

Any discussions regarding downgrading of the incident Emergency Level classification must be preceded by a thorough review of the following considerations:

- Has the release been stopped?
- Is the hazard mitigated?
- Have all public safety threats been eliminated?
- Are there any remaining risks that could escalate if the Emergency Level was downgraded?
- Has an appropriate environmental monitoring plan been initiated (surface water, groundwater, soils, wildlife, vegetation, air quality monitoring)?
- Has environmental data been collected, analyzed and is it available to be submitted to the Regulatory Authority?
- Has an environmental mitigation plan been developed based on the data collected and has it been evaluated relative to potential residual impacts?

If there is agreement on the above points between the Incident Commander, CEOC Director and the Regulatory Authority then a coordinated discussion with the Regulatory Authority can be held to obtain approval to downgrade the emergency to the appropriate level.

Once site restoration is deemed appropriate and incident facts justify the relaxation from a state of readiness or alert, the Company must make the decision to stand-down the emergency in consultation with the Regulatory Authority.

The Company must keep all notified stakeholders and evacuated persons informed of the status of an emergency.

9.3.2 Spill Reporting

NorthRiver must report all spills or releases that are or may cause an adverse effect as defined in the Responsible Energy Act and the Alberta Environmental Protection and Enhancement Act (EPEA) regarding the Energy Industry. The AER must be notified through the 24-Hour Response Line. This system is designed to streamline and standardize the reporting of spills and to ensure a coordinated, integrated response from different government agencies. The AER 24-Hour Response Line notifies both Ministry of Environment and Protective Areas (EPA) and Environment and Climate Change Canada.

Notification Requirements

For both refined and unrefined products, upon becoming aware of a reportable release, NorthRiver **must orally** notify the AER at the first available opportunity.

Upon completing the oral notification, the AER sends the licensee the Field Inspection System Number (FIS) along with the Initial Incident Report which is to be completed **within seven days** of receiving the document from the AER.

Note: NorthRiver must notify the landowner of any release that occurs off lease, or that occurs on an easement or right-of-way (Landowners can be private or any of the following: on Crown land (EPA), on reserves (First Nations), in provincial parks (tourism, parks and recreation). Landowner cooperation is essential in being able to quickly respond to a release.

For the purposes of reporting, NorthRiver shall use the following guidelines and considerations to assess whether the release may cause, is causing or has caused an adverse effect.

- Any third-party impact (off lease) e.g. crop damage, vegetation damage and livestock impact.
- Spilled substance likely to contaminate surface or ground water.
- Groundwater and/or surface water is contaminated.
- Release or spill has potential for offsite odour complaints.
- Toxic or flammable release to air going offsite.
- Chemical and physical characteristics of the substance released.
- Receiving or potential to receive media attention.
- Location of the release.

The onus is on the party who causes the release and has control of the situation to assess the adverse effect.

Adverse effect is defined in the EPEA as “impairment of or damage to the environment, human health or safety, or property”.

Unrefined products include conventional crude oil, LPG, diluents, condensate, synthetic crude, sour gas, produced water, and other produced fluids), pipeline breaks and incidents involving oilfield wastes.

Refined Product includes diesel, gasoline, sulphur, and solvents.

For further Alberta spill release reporting guidelines please refer online.

Release Reporting Requirements – Alberta

Reportable Release	Oil and Gas	Mining – Oil Sands	In situ – Oil Sands	Pipelines	Pipeline installations	Pipeline-Related Activities and Equipment
Any leak or break from a pipeline				X		
Release of a substance that may cause, is causing, or has caused an adverse effect	X	X	X	X	X	X
Release of a substance into a water body (as defined in the <i>Water Act</i>)	X	X	X	X	X	X
Release of a substance falling within the class set out in the first column of the schedule in the <i>Release Reporting Regulation</i> that may cause, is causing, or has caused an adverse effect and <ul style="list-style-type: none"> the release is at or in excess of the quantity or emission levels set out in the second column of the schedule or the substance is released into a watercourse, groundwater, or surface water 	X	X	X	X	X	X
Release of oil, water, or unrefined product off site	X	X	X	X	X	X
Release of oil, water, or unrefined product exceeding 2 m ³ on site	X	X	X	X	X	X
A liquid spill (as defined in the Oil Sands Conservation Rules)		X	X			
Release of a liquid hydrocarbon exceeding 2 m ³		X	X	X	X	X
Release of gas exceeding approved volume limits or potential for adverse conditions						X
Release of gas or gas equivalent exceeding 30 000 m ³	X	X	X	X	X	X
Well flowing uncontrolled	X	X	X			
If there are any doubts on the reporting requirements for a spill or release, report it.						

Common Unrefined Product Releases

Chemical Class*	Common Unrefined Product	Alberta Reporting Requirements	TDG Reporting Requirements (Road, Rail, or Marine)
Possibly Class 3 <ul style="list-style-type: none"> Flammable liquids 	<ul style="list-style-type: none"> Condensate Crude oil Crude emulsion Bitumen 	<ul style="list-style-type: none"> Any release which is causing, may cause, or has caused an adverse effect. Any release into a waterbody, a watercourse, groundwater, or surface water §. 	See Class 3
Substances Not Regulated by TDG	<ul style="list-style-type: none"> Produced water (saltwater & brine) Oilfield waste Drilling waste 	<ul style="list-style-type: none"> Releases greater than 2 m³ on site. Any release off site (report to AER and landowner) 	Not Regulated

* Chemical class is defined by the federal Transportation of Dangerous Goods Act (TDG). Refer to the United Nations number on the Safety Data Sheet (SDS) to determine applicable class.

§ As defined in the *Water Act* and/or as stated in the *Release Reporting Regulation*.

TDG and Provincial Reportable Releases of Common Products at Energy Sites

Chemical Class	Common Refined Product	Alberta Reporting Requirements	TDG Reporting Requirements Road, Rail or Marine
Substances Not Regulated by TDG	Glycol Hydraulic Oil Ammonia	Any release which is causing, may cause, or has caused an adverse effect. Any release into a waterbody, a watercourse, groundwater, or surface water. §	Not regulated.
Class 1 Explosives	Ammunition Nitro-glycerine	All releases that could pose a danger or 50 kg. Any release into a waterbody, a watercourse, groundwater, or surface water. §	Any quantity of Packing Group II.
Class 2.1 Flammable Gases	H ₂ S Methane Propane Butane Natural Gas	All releases which could pose a danger, or any sustained release of 10 minutes or more, or 50kgs (not related to a pipeline). Any release from a pipeline.	Any quantity.
Class 2.2 Non-Flammable, Non-Toxic, Non-Corrosive Gases	Compressed Air O ₂ N ₂ CO ₂	Any release greater than 30,000 m ³ .	
Class 2.3 Toxic Gases (Poisonous or Corrosive)	H ₂ S SO ₂ Anhydrous Ammonia Carbon Monoxide	All releases which could pose a danger, or any sustained release of 10 minutes or more, or 50kgs (not related to a pipeline). Any release from a pipeline.	
Class 3 Flammable Liquids	Demulsifiers† Diesel Gasoline Methanol† – use UN # to determine subclasses Scale Inhibitors†	Any release which is causing, may cause, or has caused an adverse effect. Any release into a waterbody, a watercourse, groundwater, or surface water. § Releases greater than 200 L (0.2 m ³) on land.	
Class 4.1 Flammable Solids	Calcium Resinate Naphthalene Crude	Any release which is causing, may cause, or has caused an adverse effect. Any release into a water body, a watercourse, groundwater, or surface water. § Releases greater than 25 kg on land.	Any quantity of Packing Group I or II. More than 30 L or 30 kg of Packing Group III or without packing group.
Class 4.2 Spontaneously Combustible	Activated Carbon Potassium Sulphide Phosphorus		
Class 4.3 Dangerous when Wet	Molten Sulphur Calcium Carbide Sodium Activated Carbon		
Class 5.1 Oxidizing Substances	Ammonium Nitrate Bleaches Calcium Nitrate	Any release which is causing, may cause, or has caused an adverse effect. Any release into a water body, a watercourse, groundwater, or surface water. § Releases greater than 50 kg or 50 L on land.	
Class 5.2 Organic Peroxides	Peroxide Methyl Ethyl Ketone Peroxide Succinic Acid	Releases greater than 1 kg or 1 L.	
Class 6.1 Poisonous Toxic Substances	Methanol Arsenic Lead Acetate Mercuric Chloride Pesticides†	Any release which is causing, may cause, or has caused an adverse effect. Any release into a waterbody, a watercourse, groundwater, or surface water. § Releases greater than 5 kg or 5 L on land.	
Class 6.2 Infectious Substances	Infectious substances affecting humans/animals.	All releases.	Any quantity of Category A or B.
Class 7 Radioactive Materials	Uranium Plutonium Naturally Occurring Radioactive Materials (NORM)	Any releases that could pose a danger to public safety or - Discharge or radiation level exceeding 10 msv/h at package surface and 200 uSv/h, 1 m from package surface. Any release into a water body, a watercourse, groundwater, or surface water. §	For packages being transported under exclusive use: (i) 10 mSv/h on the external surface of the package (ii) 2 mSv/h on the surface of the conveyance, and (iii) 0.1 mSv/h at a distance of 2 m from the surface of the conveyance. For packages not being transported under exclusive use: (i) 2 mSv/h on the external surface of the package (ii) 0.1 mSv/h at a distance of 1 m from the package, (iii) 2 mSv/h on the surface of the conveyance, and (iv) 0.1 mSv/h at a distance of 2 m from the surface of the conveyance.
Class 8 Corrosives	Acids† Amines† Bases† Batteries† Caustics† Nitric Acid	Any release that has caused, is causing, or may cause an adverse effect. Any release into a waterbody, a watercourse, groundwater, or surface water. § Releases greater than 5 kg or 5 L.	Any quantity of Packing Group I or II. More than 30 L or 30 kg of Packing Group III or without Packing Group.
Class 9 Miscellaneous Products, Substances and Organisms (Environmentally Hazardous Substances)	PCB Asbestos Polystyrene Beads Gas Plant Filters Benzoic Acid Chromic Acetate Cupric Sulphate Lithium Batteries	25 kg or 25 L Report any release from a pipeline	30 L or 30 kg of Packing Group II or III, or without Packing Group.
Other	Any well flowing uncontrolled, any burning of effluent from a well or facility and any fire where loss exceeds 2 m ³ or 30,000 m ³ of gas where damage to the wellhead occurs.		

† Product names that are commonly used to refer to a number of products that have various classifications. Refer to the product's SDS to confirm TDG classification.

§ As defined in the Water Act and/or as stated in the Release Reporting Regulation.

- Packing Group I: great danger and most protective packing required. Some combinations of different classes of dangerous goods on the same vehicle or in the same container are forbidden if one of the goods is Group I.
- Packing Group II: medium danger.
- Packing Group III: minor danger among regulated goods and least protective packaging within the transportation requirement.

9.3.3 TDG Reporting – Alberta Environmental and Dangerous Goods Emergencies (EDGE)

Alberta EDGE is a 24-hour centre that supplies technical information to industry, the public and enforcement officials about the Transportation of Dangerous Goods (TDG) Regulations and all associated standards. They are also the emergency response centre for reporting releases or anticipated releases of dangerous goods during any aspect of transport as outlined in the Regulations.

In addition, Alberta Transportation has agreements with Ministry of Environment and Protective Areas (EPA) and Alberta Energy Regulator (AER), serving as a contact point for contraventions, spills, and complaints.

Whether a release or emission originated from the oil, gas, chemical, or manufacturing industry, Albertans can feel assured that the correct departments are informed of the situation immediately and actions are taken to minimize any impact on the public, the environment or public infrastructure.

Alberta Transportation is the only jurisdiction in Canada that has dually appointed Provincial and Federal Dangerous Goods Inspectors that inspect dangerous goods facilities, monitor highway tank facilities and respond to incidents involving dangerous goods.

The Safety and Compliance Services Branch is responsible for the compliance and enforcement of the Provincial Dangerous Goods Transportation and Handling Act and Dangerous Goods Transportation and Handling Regulation as well as the Federal Transportation of Dangerous Goods Regulation which has been adopted by Alberta. Both regulations set safety standards and shipping requirements for thousands of dangerous goods, in addition to providing a means of communicating the nature and level of danger associated with various chemicals and other products.

Part 8 of the TDG Regulations details the situations and requirements for reporting of specific events involving dangerous goods. These are briefly discussed in this document. Specific sections of the Regulations have been referenced.

Any person who has the charge, management or control of the Dangerous Goods must report a release or anticipated release of dangerous goods that are being offered for transport, handled or transported by road vehicle, railway vehicle or ship as soon as possible, after a release or anticipated release. The verbal report has to be made to any local authority that is responsible for responding to emergencies at the location of the release or anticipated release. The report must be made if the dangerous goods are, or could be, in excess of the quantity set out in the following table AND if the release endangers or could endanger public safety.

TDG Reporting Requirements

Types of Report	Who must make the report?	When is the report required?	Who should receive the report?	Method of Reporting	Is a 30-day follow-up report required?
Emergency Report	Person who has the charge, management or control of the dangerous goods (DG).	<ul style="list-style-type: none"> As soon as possible; In the case of a release or an anticipated release of DG that are or could be in excess of the quantity set out in Section 8.2 of the TDG Regulations and if it endangers or could endanger public safety. 	<ul style="list-style-type: none"> Local authority responsible for emergency response. 911 (or local police; relevant provincial authorities). Alberta Transportation Canadian Coast Guard. 	Telephone (Verbal)	No
Release or Anticipated Release Report	Person who made the Emergency Report.	<ul style="list-style-type: none"> The report is required in these situations: the death of a person; a person sustaining injuries requiring immediate medical treatment by a health care provider; an evacuation of people or their shelter-in- place; the closure of a facility, road, main railway line or main waterway; a means of containment has been damaged; the centre sill or stub sill of a tank car is broken or there is a crack in the metal < 15 cm (6 inches). 	<ul style="list-style-type: none"> CANUTEC; the consignor (shipper); <p>And, if applicable,</p> <ul style="list-style-type: none"> The Canadian Nuclear Safety Commission (CNSC); or A Vessel Traffic Services Centre, or the Canadian Coast Guard. 	Telephone Followed by Written Report	Yes
Loss or Theft Report	Any person who had the charge, management or control of the dangerous goods before the loss of theft.	<ul style="list-style-type: none"> As soon as possible. In case of loss or theft if the quantity of DG is greater than the quantities indicated in Subsection 8.16(2) of the TDG Regulations. 	<ul style="list-style-type: none"> CANUTEC; <p>And, if applicable,</p> <ul style="list-style-type: none"> Natural Resources Canada, or CNSC. 	Telephone (Verbal)	No
Unlawful Interference Report	Person who has the charge, management or control of the dangerous goods (DG).	<ul style="list-style-type: none"> As soon as possible after it is discovered that dangerous goods have been unlawfully interfered with. 	<ul style="list-style-type: none"> CANUTEC; <p>And, if applicable,</p> <ul style="list-style-type: none"> Natural Resources Canada; or CNSC. 	Telephone (Verbal)	No

For a detailed description of the information required in the report, refer to the Emergency Release or Anticipated Release Report Requirements (Alberta Government, February 2020).

9.3.4 Emergency Planning and Response Zones

Various factors will determine the extent of the EPZ:

- The nature of the product released.
- The volume released.
- The product flow rate.
- Weather or meteorological conditions.
- Topography.

For sour gas/emulsion properties the calculated EPZ is the distance to the time weight average of 100-ppm H₂S over a 60-minute period which is equivalent to 235 ppm for 3 minutes. This pre-calculated zone serves as the initial defined spatial area of response efforts until the sour gas hazard can be assessed using gas monitoring equipment to determine actual conditions.

To determine the size of the response zones, response personnel should approach the perimeter of the response zone cautiously so as not to exceed personal exposure limits and begin monitoring with handheld equipment at the nearest residence. Note that the H₂S personal exposure limit in Alberta is 10 ppm (8-hour exposure limit) and 15 ppm (ceiling exposure limit).

From this location, the response personnel should continue to approach any additional downwind residences that may be closer to the release until the outer boundary of the response zone is determined.

Whereas the EPZ is used for planning purposes. It reflects an area where significant exposure could result without prompt action, actual conditions during an incident need to be assessed to ensure an appropriate initial response. The response zones are where resources are focused during an incident to protect public safety. A licensee should also be aware that a different type and size of response zone could be established by the police if a bomb has been confirmed at the pipeline, well, or facility.

Response Zones

The Emergency Planning Zone (EPZ) is a geographical area surrounding a licensed well, pipeline and/or facility containing hazardous product that requires specific emergency response planning by the licensee. During any operations involving H₂S or HVP product, the licensee must ensure that on-site personnel are aware of the size of the EPZ. In the case of a sour gas or toxic hazardous gas release the initial hazard area is the predefined EPZ determined using the ERCBH₂S model shown on the area maps. The size and shape of the hazard area or EPZ may change with the nature of the incident and any related data from the incident, such as air or environmental monitoring results.

The Initial Isolation Zone (IIZ) defines an area in close proximity to a continuous hazardous release where indoor sheltering may provide temporary protection due to proximity of the release. If safe to do so, the licensee must attempt to evacuate the residents from the IIZ.

The Protective Action Zone (PAZ) is an area downwind of a hazardous release where outdoor concentration levels may result in life threatening or serious and possibly irreversible health effects to the public. Immediately following a release of the H₂S or HVP product, the approximate size and direction of the PAZ can be determined using actual conditions at the time. The PAZ is a triangular area that starts at the IIZ and runs outwards to the edge of the EPZ. The PAZ is estimated to initiate priority response actions within the EPZ.

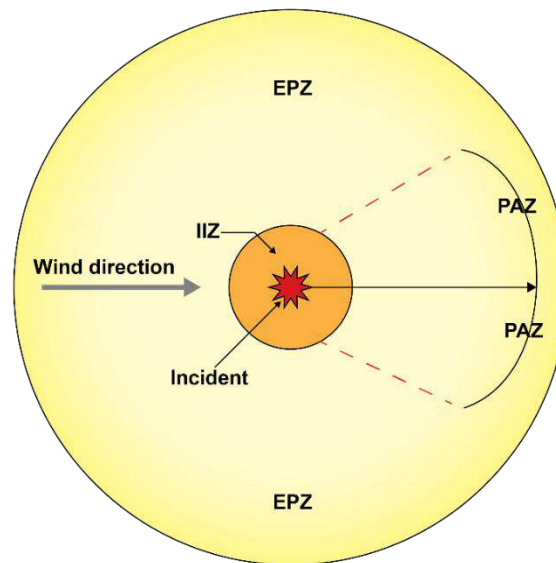

Initial Isolation and Protective Action Zones for illustration purposes only

9.3.5 Methods of Public Protection

If the health and safety of the public cannot be assured, then the Company must determine the best approach for protecting the public. Depending on the severity of the emergency, the Company will implement one of three approaches to public protection: sheltering, evacuation, or ignition.

The purpose of public protection measures is to proactively address public health and safety concerns and to take appropriate response actions to protect the public from harm. This may include removing or reducing the hazards and asking public stakeholders to shelter and/or evacuate as required.

It is the Company's responsibility to initiate public protection measures in the EPZ for any incident involving a release of sour gas product if there is potential for the release to impact members of the public. This could also include SO₂ if the sour gas release was ignited.

The type of public protection measure employed depends on the severity of the incident and/or on the monitored results in the unevacuated areas. The licensee is responsible for ensuring that appropriate emergency response procedures are in place and can be implemented, including for areas of potential impact beyond the EPZ.

Affected Parties within a Predetermined EPZ

- Permanent and part-time residents, including those residing on dead-end roads, beyond a predetermined EPZ, where occupants are required to egress through the EPZ.
- Business owners and/or operators and industrial operators, including oil and gas operators with manned facilities inside a predetermined EPZ.
- Private and public recreational property owners and/or operators (e.g. campgrounds, trapper cabin, private cabins, etc.) in and adjacent to a predetermined EPZ.
- Public facilities and publicly used development, such as schools and community centres in or adjacent to a predetermined EPZ.
- Non-resident landowners or farmers renting land who do not dwell on the property but whose lands are within a predetermined EPZ. These persons must be considered in the development of the ERP and be advised their property lies within the EPZ.
- First Nation reserves, registered trappers, guides, outfitters, and registered grazing lease rights holders or any other rights holders if the EPZ impacts the safety or livelihood of these stakeholders.
- Oil and gas operators with unmanned assets (e.g. wells, pipelines, facilities, etc.) in a predetermined EPZ whose activities may be impacted in the event of an emergency.

Public Protection Decision Tree

Use the following Public Protection Decision Tree for all planning and response zones:

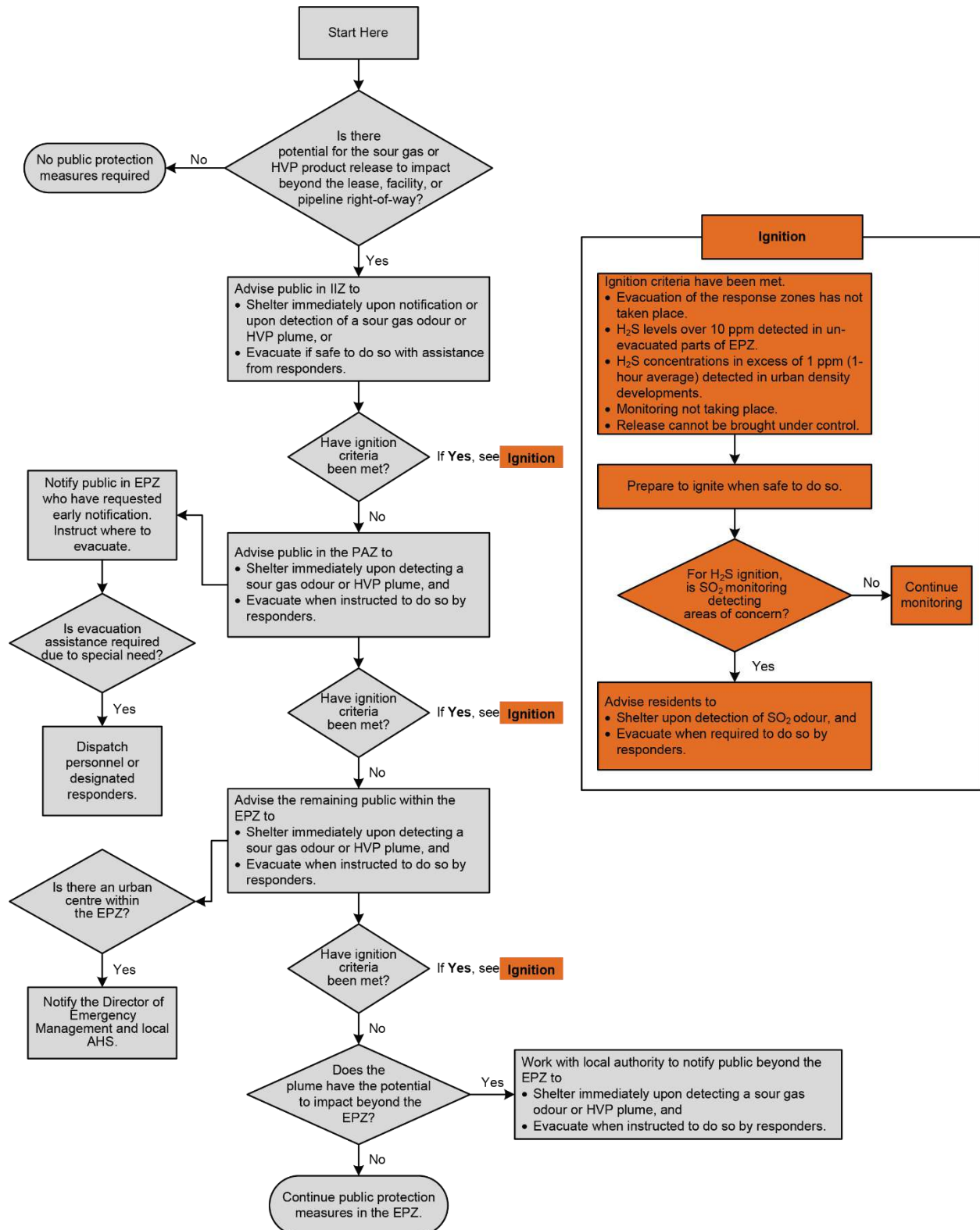

Air Quality Monitoring During an Incident

During an emergency, active air monitoring should be used to assist the Company in determining:

- If ignition concentration criteria are met
- Whether evacuation or sheltering concentration criteria are met
- Whether the concentrations are safe in which the areas being evacuated to
- Access control locations

Using stationary and/or mobile air quality monitoring units and personal handheld monitors, air quality monitoring may occur downwind or upwind depending on how the plume is tracking. The Company will prioritize the nearest residence or areas where people may be present. Monitoring multiple urban density developments or a large urban centre may require additional air monitoring units.

Regular updates on monitored H₂S and SO₂ levels and the lower flammable limit levels for HVP products must be provided to the AER, Alberta Environment and Protected Areas, other appropriate authorities, and the public if requested.

When mobile air quality monitors cannot be provided, the Company will consider source equipment from a third-party vendor, or utilize reasonable alternative air monitoring techniques, to be determined at time of necessity.

Sheltering

Sheltering may be the safest and most viable public protection measure in avoiding exposure to toxic or combustible gases in the following situation:

- Incident is of relatively short duration.
- Source of a release is uncertain.
- Residents are waiting for evacuation and transportation assistance.
- Not enough time is available to safely evacuate residents.
- Evacuation poses a higher risk to evacuees.

Residents will be asked to remain inside and ensure that all windows and doors are closed and that all air intakes (furnace, stove, bathroom, and dryer vents) are plugged to limit exposure to outside air until the situation is rectified or they are further notified.

Note: For general Shelter in Place Instructions, refer the Response Action Plans Section in this document.

Evacuation

Safe evacuation is the primary public protection measure for long term H₂S, SO₂, or other toxic releases. Evacuation begins in the IIZ and radiates outward into the PAZ downwind of the release.

Evacuation must begin at the declaration of a Level 2 Emergency. The licensee must continuously assess and act on the need to expand the evacuation area based on the monitored levels of H₂S, SO₂, and other toxic releases.

Public within the IIZ must be evacuated or sheltered first. Once the IIZ has been secured, responders will address the public within the PAZ, downwind of the incident site. Once the PAZ has been secured, responders will address the public in the rest of the EPZ as necessary.

Evacuation of occupants inside the defined IIZ, PAZ and EPZ shall be prioritized as above and in the following manner:

1. Individuals located immediately downwind or adjacent to the incident site.
2. Individuals who have indicated they have special needs or require assistance.
3. Individuals who cannot be contacted by telephone.

Should area users be affected by an emergency involving Company operations, the response personnel will notify stakeholders by telephone or by personal contact with Rovers. A notice of evacuation is also placed on any unattended vehicles in the evacuation area and on doors of residences who are not home and cannot be contacted by phone.

Note: Individuals who have been identified as having special needs should be treated with priority and may choose to evacuate an area at an earlier time than other residents. These individuals may be highly responsive or sensitive to H₂S or other toxic gases.

Evacuation Requirements

H ₂ S concentrations in unevacuated areas	Requirements
1 to 10 ppm (3-minute average)	Individuals who requested notification so that they can voluntarily evacuate before any exposure to H ₂ S must be notified.
Above 10 ppm (3-minute average) *	Local conditions must be assessed, and all persons must be advised to evacuate and/or shelter.
*If monitored levels over the 3-minute interval are declining (e.g., three readings show a decline from 15 ppm to 10 ppm to 8 ppm over 3 minutes), evacuation may not be necessary even though the average over the 3-minute interval would be 11 ppm. The company should use proper judgement in determining if evacuation is required.	
SO ₂ concentrations in unevacuated areas	Requirements
5 ppm (15-minute average) 1 ppm (3-hour average) 0.3 ppm (24-hour average)	Immediate evacuation of the area must take place.

If evacuation is initiated, the Company will establish a Reception Centre at a designated location. The Public Protection Group Supervisor will dispatch a representative to open the Reception Centre and record the arrival of evacuated stakeholders.

To ensure public safety, Company personnel will coordinate their public safety actions with the Local Authority.

Evacuation outside of the EPZ

The evacuation of the public outside of the EPZ may be required if the incident cannot be controlled and/or H₂S, SO₂, or other toxic releases concentrations reach the maximum allowable limits adjacent to the EPZ boundary. In the unlikely event that public protection measures are required beyond the EPZ, they will be conducted in accordance with the licensee’s arrangement with the local authority.

Alberta Municipal Affairs and Alberta Emergency Management Agency, local Disaster Services and the Alberta Regional Health Authority, in conjunction with the industrial operator, shall coordinate the evacuation outside the EPZ in accordance with the Energy Resources Industry Emergency Support Plan. The Company shall provide the necessary personnel and equipment deemed necessary to assist. The AER shall be available for assistance if required.

Ignition

Ignition is the final means of protecting the public when evacuation is impractical, and the safety of the public/Company personnel is threatened. The decision to ignite a release will be made in conjunction with the Incident Commander and an AER Representative, if time permits.

If an immediate threat to human life exists and there is not sufficient time, the Incident Commander is authorized to ignite the release. This decision to ignite will be fully supported by Management.

Company personnel are expected to take immediate steps to prepare for ignition at the earliest signs of a release or a well control problem to ensure there will be no delay.

The company must:

- Ensure that appropriate ignition equipment is available during all operations.
- Assign the decision-making authority to ignite the release to a licensee representative on-site.
- Ignite a sour gas flow to atmosphere in accordance with the Assessment and Ignition Criteria Flowchart.
- If an uncontrolled release is ignited to protect the public, continuous monitoring for SO₂ or H₂S in the surrounding area would determine if public evacuation becomes necessary.

The ignition team must be certified in sour well ignition and properly equipped to ignite the well within the planned time limits for which the EPZ was designed. Certification in ignition training may be obtained from Enform or from other training facilities that have a comparable program.

AER senior staff may make the decision to ignite a release if the licensee does not agree to ignite the release or is not prepared to take the necessary steps.

Ignition doesn't negate the need for continuing with evacuation as there may be residual pockets of H₂S or SO₂ in the area.

It is important that mobile air quality monitoring be dispatched as quickly as possible to the emergency site because specialized monitoring equipment can more accurately record readings in the emergency area.

Assessment and Ignition Criteria Flowchart

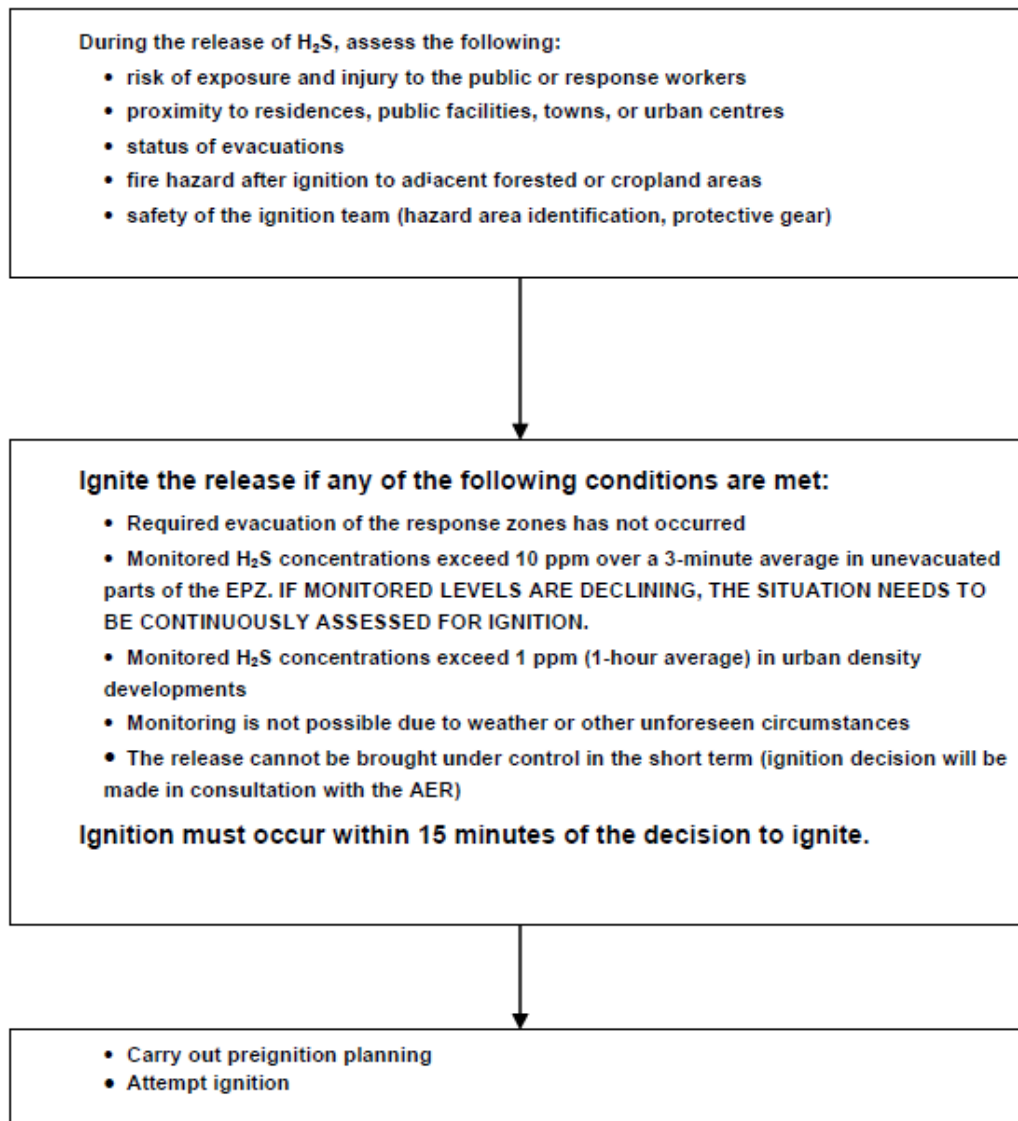

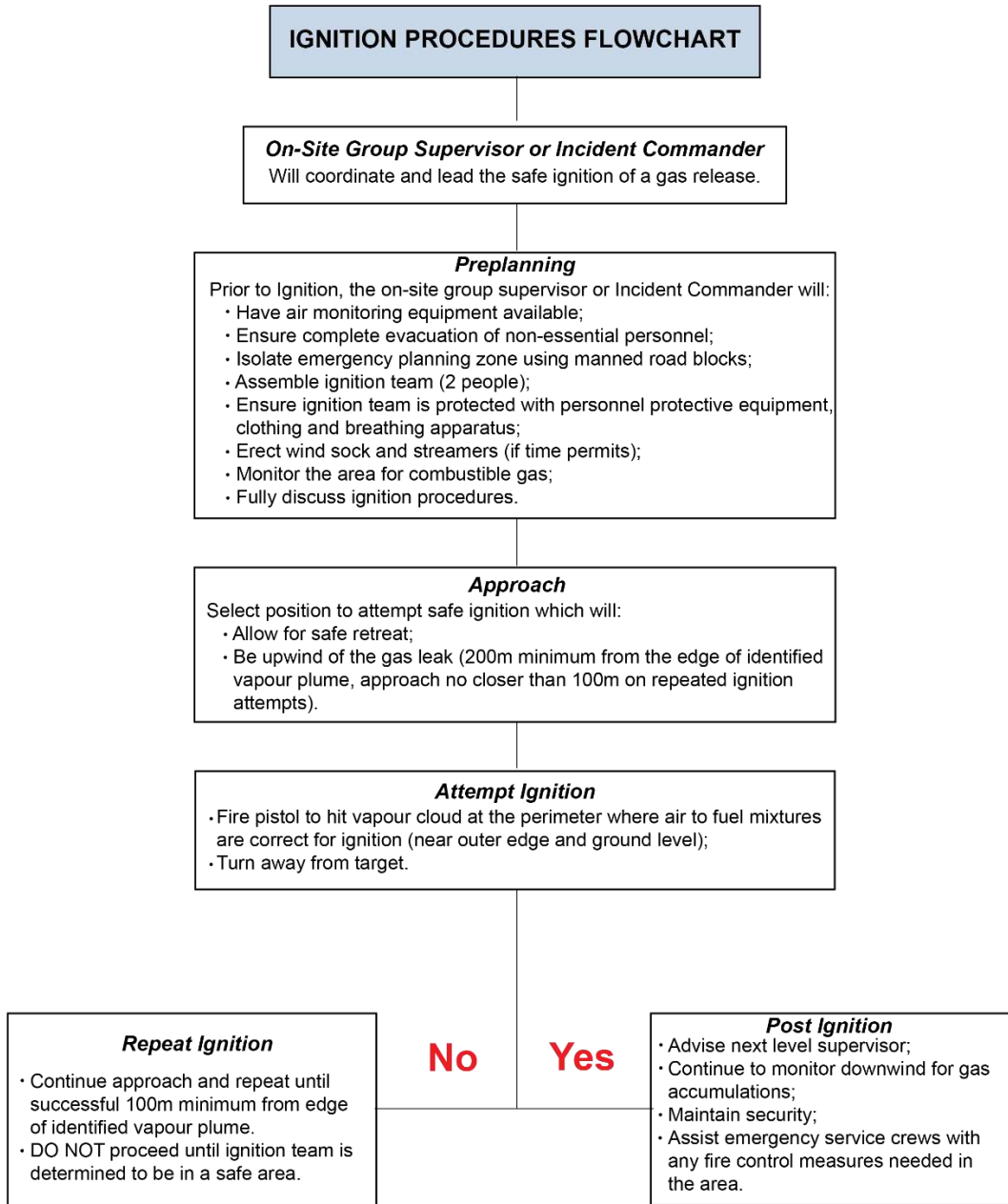

9.3.6 Closure Orders

NOTAM

It may be necessary for NAV Canada to issue a Notice to Airmen (NOTAM) to advise pilots of restrictions in the airspace above the EPZ or to close the airspace for a certain radius from the release (a no-fly zone). NOTAMs or closure of airspace may be requested by the AER at a Level 2 or 3 emergency.

9.3.7 Government Roles and Responsibilities

Provincial Emergency Coordination Centre (PECC)

The Provincial Emergency Coordination Centre (PECC) plays a crucial role in managing and coordinating emergency responses at the provincial level. Its primary function is to provide leadership, support, and resources to local governments and emergency management agencies during emergencies. to ensure an effective disaster response.

PROVINCIAL EMERGENCY COORDINATION CENTRE	
<input type="checkbox"/>	Acts as the central hub for coordinating emergency response efforts across municipalities and regional authorities.
<input type="checkbox"/>	Supports local Emergency Operations Centres (EOCs) when incidents exceed local capacity by providing resources, guidance, and reinforcements as needed.
<input type="checkbox"/>	Coordinates with federal agencies, municipal governments, and Indigenous communities.
<input type="checkbox"/>	Ensures a unified provincial response during major disasters.
<input type="checkbox"/>	Identifies and distributes critical resources such as personnel, equipment, and financial aid to affected areas.
<input type="checkbox"/>	Coordinates transportation and supply chain logistics to deliver emergency relief efficiently.
<input type="checkbox"/>	Works with public and private sector partners to ensure rapid deployment of emergency supplies.
<input type="checkbox"/>	Facilitates inter-agency communication to ensure a consistent flow of information.
<input type="checkbox"/>	Acts as the official provincial source for emergency updates, warnings, and advisories to the public, media, and government leaders.
<input type="checkbox"/>	Maintains situational awareness through GIS mapping, weather tracking, and damage assessments.
<input type="checkbox"/>	Advises the provincial government on emergency response strategies.
<input type="checkbox"/>	Helps in declaring states of emergency when required.
<input type="checkbox"/>	Ensures emergency response aligns with provincial laws, regulations, and emergency management frameworks.
<input type="checkbox"/>	Works with federal agencies (e.g. Public Safety Canada) to comply with national emergency protocols.
<input type="checkbox"/>	Develops and enforces emergency response policies, including evacuation procedures and disaster relief measures.
<input type="checkbox"/>	Oversees response efforts during emergencies, such as natural disasters, pandemics, or industrial incidents.
<input type="checkbox"/>	Supports evacuation coordination, sheltering, and emergency aid distribution.
<input type="checkbox"/>	Assists in long-term recovery efforts, including rebuilding infrastructure, financial aid distribution, and community support programs.
<input type="checkbox"/>	Works on resilience planning to mitigate future risks and improve disaster preparedness.
<input type="checkbox"/>	Coordinates emergency alerts and public service announcements.
<input type="checkbox"/>	Provides safety guidelines and preparedness training to communities.
<input type="checkbox"/>	Engages with media, stakeholders, and the public to ensure clear and accurate communication.
<input type="checkbox"/>	Works with municipal governments, Indigenous communities, NGOs, and private sector partners.
<input type="checkbox"/>	Liaises with the federal government for additional support and funding.
<input type="checkbox"/>	Collaborates with law enforcement, military, health agencies, and emergency services.

PROVINCIAL EMERGENCY COORDINATION CENTRE

Alberta Energy Regulator

The AER ensures the safe, efficient, orderly, and environmentally responsible development of hydrocarbon resources over their entire life cycle. This includes allocating and conserving water resources, managing public lands, and protecting the environment while providing economic benefits for all Albertans.

The AER will provide full-lifecycle regulatory oversight of energy resource development in Alberta - from application and construction to abandonment and reclamation, and everything in between.

The AER is the lead government agency that initiates and oversees government response. The AER can provide assistance to alert other applicable government and emergency response agencies.

ALBERTA ENERGY REGULATOR	
<input type="checkbox"/>	Acts as lead provincial government organization in petroleum industry emergency responses.
<input type="checkbox"/>	Review and approve licensee ERPs.
<input type="checkbox"/>	Participate in selected licensee ERP exercises.
<input type="checkbox"/>	Review and recommend changes to ERPs.
<input type="checkbox"/>	Participate in validation and testing of ERPs.
<input type="checkbox"/>	Maintain a 24-hour emergency contact number where resources can be accessed for a response related to Emergency Response Plans.
<input type="checkbox"/>	Receive information pertaining to petroleum industry incidents.
<input type="checkbox"/>	Determine the emergency level of an incident through consultation with the licensee.
<input type="checkbox"/>	Dispatch AER representative to the site of the incident, as required.
<input type="checkbox"/>	Confirm that local resources have been notified as appropriate.
<input type="checkbox"/>	Identify and request initial provincial resources to support the incident, to be coordinated at the regional level if necessary, through the REOC.
<input type="checkbox"/>	Notify EDGE to carry out notification in accordance with this plan.
<input type="checkbox"/>	Provide Situation Reports to AEMA if requested.
<input type="checkbox"/>	Send AER representative to the On-Site Command Post.
<input type="checkbox"/>	Establish an EOC at the local AER Field Centre until the licensee or local authority establishes a MEOC.
<input type="checkbox"/>	Dispatch an AER Regulatory Liaison to the MEOC or PECC and issue timely media releases in conjunction with the licensee and PAB.
<input type="checkbox"/>	Request, through AEMA, the deployment of the other provincial Government staff be sent to the MEOC or the local Field Centre EOC.
<input type="checkbox"/>	Request a local authority liaison officer to be present at the MEOC if necessary.
<input type="checkbox"/>	Carry out investigations.
<input type="checkbox"/>	Provide timely situation reports, through AEMA, to other Government departments activated by this plan.
<input type="checkbox"/>	Notify all participants when the event has concluded and there is no longer any hazard to the public.
<input type="checkbox"/>	Complete reporting protocols.
<input type="checkbox"/>	As part of the lessons-learned process, recommend any mitigating actions that may reduce the event from re-occurring.
<input type="checkbox"/>	Establish processes to receive and address community concerns.
<input type="checkbox"/>	In consultation with AEMA, review and recommend updates for the ERP.

ALBERTA ENERGY REGULATOR

Ministry of Environment and Protective Areas

MINISTRY OF ENVIRONMENT AND PROTECTIVE AREAS	
<input type="checkbox"/>	Maintain a 24-hour emergency contact number where resources can be accessed for a response related to Emergency Response Plans.
<input type="checkbox"/>	Provide oversight role in ensuring air quality monitoring needs and activities associated with public safety around the event site are adequately addressed by the licensee.
<input type="checkbox"/>	Ensure the air quality monitoring log is being maintained.
<input type="checkbox"/>	Participate in the evaluation of the incident and the potential area at risk from product releases.
<input type="checkbox"/>	Provide assistance in monitoring discharges and ensuring appropriate mitigation and response actions are taken to reduce the impact of liquid releases for land-based spills and to ensure watercourses are protected.
<input type="checkbox"/>	Assist in notifying Fish and Wildlife personnel of the hazard.
<input type="checkbox"/>	Monitor environmental recovery, when required.
<input type="checkbox"/>	Compile and maintain environment related records and log.
<input type="checkbox"/>	Request and review environmental impact assessment if necessary.
<input type="checkbox"/>	Carry out investigation, when required, having regard for the existing investigative protocols and procedures.
<input type="checkbox"/>	Investigate non-compliance with the EPEA and the Water Act. The investigation may be coordinated with, or independent of any other investigation in relation to the incident.

MINISTRY OF ENVIRONMENT AND PROTECTIVE AREAS

Alberta Agriculture and Forestry

ALBERTA AGRICULTURE AND FORESTRY	
<input type="checkbox"/>	Maintain a 24-hour emergency contact number where resources can be accessed for a response related to Emergency Response Plans.
<input type="checkbox"/>	Assist the industrial operator and/or the local authority in establishing and maintaining roadblocks. If requested.
<input type="checkbox"/>	Assist in notifying Forestry personnel of the hazard.
<input type="checkbox"/>	Assist in locating transients for evacuation in cooperation with licensee and local authority.
<input type="checkbox"/>	Inform transients within the hazard area of the incident and safety measures to take including evacuation details as applicable.
<input type="checkbox"/>	Fight any fires started as the result of the product release within the Forest Protection Area.
<input type="checkbox"/>	Compile and maintain event records and log.
<input type="checkbox"/>	Conduct forest impact assessment.
<input type="checkbox"/>	Complete reports concerning the incident.

ALBERTA AGRICULTURE AND FORESTRY

Occupational Health and Safety

The Occupational Health and Safety Branch operates within the Ministry of Jobs, Skills, Training, and Labour. OHS promotes health and safety through partnerships, resources, education and enforcement of the Occupational Health and Safety Act.

The Occupational Health and Safety Act sets standards for the protection of workers throughout the Province. Employers are required to ensure the health and safety of workers on the site.

OHS is responsible for the compliance policy and procedures implemented as a result of employee injuries/or death. Compliance policies and procedures are updated periodically.

OCCUPATIONAL HEALTH AND SAFETY	
<input type="checkbox"/>	Maintain a 24-hour emergency contact number where resources can be accessed for a response related to Emergency Response Plans.
<input type="checkbox"/>	Maintain the capacity to send an OHS officer to the PECC on a 24-hour a day, 7 day a week basis.
<input type="checkbox"/>	Monitor the health and safety aspect of applicable occupations within the hazard area to ensure that the necessary precautions are taken to protect worker safety.
<input type="checkbox"/>	Compile and maintain health and safety related records and log.
<input type="checkbox"/>	Monitor lease holder/contractor's plan to determine if site is safe for recovery workers.
<input type="checkbox"/>	Investigate non-compliance with the Occupational Health and Safety Act. The investigation may be coordinated with, or independent of, any other investigation in relation to the incident.

OHS

Local Authority

Municipal Emergency Plans

Municipal Emergency Plans vary depending on the circumstances of each community. Generally, they deal with the following:

- Authority of the Plan.
- Implementation.
- Direction and Control.
- Organization and Functions.
- Tasks.
- Communications.
- Transportation.
- Health Units.
- Hazard Analysis.
- Medical Service.
- Police.
- Fire Service.
- Public Works.
- Social Services.
- Evacuation and Reception.

LOCAL AUTHORITY	
<input type="checkbox"/>	Maintain a 24-hour emergency contact number where resources can be accessed for a response related to Emergency Response Plans.
<input type="checkbox"/>	Conduct a hazard assessment of petroleum facilities and operations.
<input type="checkbox"/>	Work with the operator to effectively prepare for a petroleum industry incident. Provide input to the industrial operator's Emergency Response Plan to ensure it is compatible with the municipal emergency plan (MEP).
<input type="checkbox"/>	Include preparedness and response information concerning facilities and operations in the MEP.
<input type="checkbox"/>	Train personnel to carry out function as assigned by the MEP or procedures.
<input type="checkbox"/>	Assess emergency incident and evaluate operator response with the AER.
<input type="checkbox"/>	Activate the emergency public warning system to alert people to life threatening hazards, as required.
<input type="checkbox"/>	Initiate public protection option, as required if resources are available.
<input type="checkbox"/>	Maintain communication with industrial operator during emergency.
<input type="checkbox"/>	Activate the MEP, in accordance with local authority policy.
<input type="checkbox"/>	Manage the local authority's emergency response.
<input type="checkbox"/>	Dispatch a representative to the incident command post, if resources are available.
<input type="checkbox"/>	Activate the MEOC, as required by the municipality.
<input type="checkbox"/>	Coordinate with the industrial operator, the establishment and the administration of reception centres for evacuees, as required.
<input type="checkbox"/>	Assist with the establishment of roadblocks and maintain them if resources are available.
<input type="checkbox"/>	Assist with fire protection (secondary fires only).
<input type="checkbox"/>	If necessary, declare a local state of emergency, as determined by the local authority.
<input type="checkbox"/>	Coordinate a public information service, including the use of the news media to inform and instruct the public of the emergency and of any protective actions to be taken.
<input type="checkbox"/>	Provide timely news releases.
<input type="checkbox"/>	Inform Municipal Affairs, Emergency Management Alberta and the public when the emergency is over in accordance with the Energy Resources Industry Emergency Support Plan.
<input type="checkbox"/>	Conduct a damage assessment to the extent of government infrastructure (roads/bridges).
<input type="checkbox"/>	Compile a municipal log.
<input type="checkbox"/>	Properly shutdown MEOC as appropriate.
<input type="checkbox"/>	Conduct municipal incident debriefing.
<input type="checkbox"/>	Participate in multi-agency debriefings if resources are available.
<input type="checkbox"/>	Review and update the municipal emergency plan.
<input type="checkbox"/>	Communicate any changes to the plan to all plan holders.
<input type="checkbox"/>	Track costs associated with the response.

LOCAL AUTHORITY

Emergency Services: Police, EMS, and Fire Fighting

EMERGENCY SERVICES	
<input type="checkbox"/> Understand the hazards associated with the petroleum facilities and operations within the area.	EMERGENCY SERVICES
<input type="checkbox"/> Work with the operator to effectively prepare for a petroleum industry incident.	
<input type="checkbox"/> Understand the response role when there is a private and public-sector response.	
<input type="checkbox"/> Train personnel to carry out their functions when there is an incident.	
<input type="checkbox"/> Establish contact with the industrial operator.	
<input type="checkbox"/> Prior to dispatching staff to scene, determine the hazards associated with the incident.	
<input type="checkbox"/> Determine where roadblocks are established.	
<input type="checkbox"/> Where applicable, maintain roadblocks as necessary.	
<input type="checkbox"/> Determine the direction of approach to the incident.	
<input type="checkbox"/> Determine if there are any injuries.	
<input type="checkbox"/> Find out what response and public protection actions have been taken by the operator.	
<input type="checkbox"/> Initiate public protection option, when necessary.	
<input type="checkbox"/> Identify what resources are required and where they should be staged.	
<input type="checkbox"/> Determine the location of the On-Site Command Post.	
<input type="checkbox"/> Respond and assess emergency incident.	
<input type="checkbox"/> Communicate to REOC and provide situation reports as required.	
<input type="checkbox"/> Dispatch a representative to the REOC, when it is established to coordinate the response.	
<input type="checkbox"/> Assist with fire protection, where applicable.	
<input type="checkbox"/> Provide emergency medical assistance, as required.	
<input type="checkbox"/> Compile response logs.	
<input type="checkbox"/> Participate in municipal incident debriefing.	
<input type="checkbox"/> Participate in multi-agency debriefings.	

Alberta Emergency Management Agency

The Alberta Emergency Management Agency is a division of the Ministry of Municipal Affairs and Housing. AEMA leads the coordination, collaboration and co-operation of all organizations involved in the prevention, preparedness, and response to disasters and emergencies.

AEMA has its headquarters in Edmonton and incorporates several domains of practise which encompass; emergency response, disaster recovery programs, business continuity, government ERPs, grants and funding, and municipal wildfire assistance programs.

The AEMA management structure is divided into two divisions: Provincial Operations, and Public Safety initiatives. Each separate division has five separate branches who report to an executive director. A Director oversees all activities of the Agency.

AEMA maintains a 24-hour a day, 7 day a week Agency Response and Readiness Centre (AARC) that monitors and maintains contact with various regional and local authorities. This centre is the central point of contact for the collection, evaluation, and dissemination concerning a single incident or for multiple incidents. The centre is responsible for co-ordinating an initial response at which time it will change roles into an active management centre known as the Provincial Emergency Coordination Centre (PECC). The PECC is responsible for establishing and maintaining contacts with federal assistance and agencies.

ALBERTA EMERGENCY MANAGEMENT AGENCY	
<input type="checkbox"/>	Act as the provincial coordinating agency in petroleum industry emergency responses as per the Emergency Management Act.
<input type="checkbox"/>	Make the plan available to stakeholders.
<input type="checkbox"/>	Train provincial personnel to carry out functions as assigned by their emergency plan or procedures.
<input type="checkbox"/>	Communicate changes to the plan with plan holders.
<input type="checkbox"/>	Maintain 24-hour a day, 7 day a week duty manager system.
<input type="checkbox"/>	Assist in the planning and coordination of exercises with the AER.
<input type="checkbox"/>	Confirm AER has been notified.
<input type="checkbox"/>	Conduct the Initial Response Report (IRR) notification.
<input type="checkbox"/>	Obtain a situation report from the AER, EPA, local authority, etc.
<input type="checkbox"/>	Confirm the level of emergency.
<input type="checkbox"/>	Activate the Provincial Emergency Coordination Centre (PECC) as required.
<input type="checkbox"/>	Notify the appropriate provincial officials as per standard operating procedures.
<input type="checkbox"/>	Release consolidated SITREPs in accordance with the Energy Resources Industry Emergency Support Plan.
<input type="checkbox"/>	Coordinate the Government of Alberta response including requests for provincial/federal resources.
<input type="checkbox"/>	Provide ongoing situation reports or briefing notes to appropriate provincial officials.
<input type="checkbox"/>	Notify partners and stakeholders when the event is over.
<input type="checkbox"/>	Conduct the post-incident assessment.
<input type="checkbox"/>	Communicate any changes to the plan to all plan holders.
<input type="checkbox"/>	Complete documentation or reporting in relation to the activation of the Energy Resources Industry Emergency Support Plan and the incident.

ALBERTA EMERGENCY MANAGEMENT AGENCY

*Alberta Health Services***ENVIRONMENTAL PUBLIC HEALTH ROLES AND RESPONSIBILITIES**

Alberta Health Services (AHS) - Environmental Public Health (EPH) roles and responsibilities in public health emergency preparedness and response to the oil and gas industry are outlined below. The provision of services during an emergency depends upon our assessment of legislative responsibilities, impact to services, and business continuity.

EPH will endeavor to:

- Participate with the Licensee in the development of their Emergency Response Plans as it relates to the Environmental Public Health Program's role and responsibility.
- Provide the AHS Zone Single-Point-of-Contact (SPOC) emergency phone number to enable the Licensee to notify and alert the Zone of an emergency. From the initial notification or alert, AHS emergency response will fan out to and coordinate with other AHS programs and facilities as necessary. The 911 EMS services remain independent of the Zone SPOC notification/alert process.
- Participate with stakeholders in preparedness training and exercises associated with a Licensee's simulated activation of an Emergency Response Plan in which EPH has a role and responsibility.
- Participate in public information sessions during the Licensee's Emergency Response Plan development process when appropriate and as resources allow.
- Provide guidance to stakeholders and local municipal authorities in identifying sites suitable for establishing and operating an evacuation centre and/or reception centre, including operational requirements.
- Provide guidance to stakeholders on substances that may affect public health in consultation with the Zone Medical Officer of Health (MOH), including Alberta Health Acute Exposure Health Effects for Hydrogen Sulphide and Sulphur Dioxide information.
- Conduct assessments, inspections and give regulatory direction, when appropriate, to ensure the requirements of provincial legislation and EPH program areas of responsibilities for public health protection and disease prevention are maintained.
- Notify the Zone Medical Officer of Health of any incident affecting or potentially affecting other AHS programs or facilities. The Zone MOH will notify and coordinate emergency response in other program areas and facilities as necessary.
- Establish EPH emergency management operations, when appropriate, to support regional response efforts and liaise with the Government Emergency Operations Centre, Municipal Emergency Operations Centre and/or Industry Emergency Operations Centre, if needed.
- Assist the Zone Medical Officer of Health, local municipal authority, and Public Information/Communication officers in the development, issuance, and rescinding of public health, public evacuation and shelter-in-place advisories.
- Provide guidance to stakeholders on matters relating to evacuation of the public and/or public facilities, and the re-occupancy of those evacuated areas or facilities.
- Record and respond to health complaints or concerns from the public during and following an incident.
- Participate in stakeholder debriefings as necessary.

First Nations and Inuit Health

FIRST NATIONS AND INUIT HEALTH	
Before the Event.	
<input type="checkbox"/>	Maintain 24-hour emergency contact numbers where resources can be accessed to carry out a response related to the Energy Resources Industry Emergency Support Plan.
<input type="checkbox"/>	Participate in provincial and industrial operators' preparatory training and exercises where feasible.
<input type="checkbox"/>	Liaise with other federal departments where needed.
During the Event	
<input type="checkbox"/>	Provide environmental public health advice to health care or special care facilities on First Nation reserves related to adverse environmental conditions resulting from a petroleum incident.
<input type="checkbox"/>	Investigate environmental public health related complaints from on-reserve Indigenous communities.
<input type="checkbox"/>	Provide guidance on public health advisories, public evacuation and sheltering for first nation communities.
In addition to the primary roles above, the following assistance will be provided during an event:	
<input type="checkbox"/>	Provide representation at the off-site REOC or when established, if requested and if available
<input type="checkbox"/>	Assist with messaging to provide accurate information to the public concerning the incident
<input type="checkbox"/>	Provide guidance and assistance at Evacuation Centre(s) to help ensure that public health standards are being met.
<input type="checkbox"/>	Provide health related information about toxic chemicals and by-products when the products or their make-up are known and reported.
<input type="checkbox"/>	Provide guidance on rescinding and declaration of public evacuation and on allowing re-occupancy – consultative capacity only.
<input type="checkbox"/>	Provide advice to the REOC on existing or potential health effects associated with the incident where possible
<input type="checkbox"/>	When possible, work with all other responders to establish a single Regional Emergency Operations Centre (REOC).
After the Event	
<input type="checkbox"/>	Compile and maintain environmental public health related documents on inspected facilities.
<input type="checkbox"/>	Participate in PIA (Post Incident Assessments).
<input type="checkbox"/>	Provide guidance on assessing and mitigating public health risks following an upstream petroleum incident.
FIRST NATIONS AND INUIT HEALTH	

Alberta Transportation

ALBERTA TRANSPORTATION	
<input type="checkbox"/>	Maintain a 24-hour emergency contact number where resources can be accessed for a response related to Emergency Response Plans.
<input type="checkbox"/>	Respond to Dangerous Goods transportation emergencies in Alberta.
<input type="checkbox"/>	Manage transportation route closures.
<input type="checkbox"/>	Provide assistance with the closure of provincial highways in the establishment of suitable detour routes.
<input type="checkbox"/>	Provide advice and assistance with the procurement of roadblock equipment.
<input type="checkbox"/>	Ensure that all requests and reports are completed.
<input type="checkbox"/>	Work with the appropriate local authority to facilitate the restoration of roadways.
ALBERTA TRANSPORTATION	

Public Affairs Bureau

PUBLIC AFFAIRS BUREAU	
<input type="checkbox"/>	Maintain a team of trained Public Affairs personnel.
<input type="checkbox"/>	Confirm distribution of AER messaging. Provide support as required.
<input type="checkbox"/>	Activate Crisis Communication Plan and Crisis Communications Response.
<input type="checkbox"/>	Advise AEMA if media boardroom will be required for media events.
<input type="checkbox"/>	Coordinate key messaging with the AER.
PAB	

Alberta Justice and Solicitor General

ALBERTA JUSTICE AND SOLICITOR GENERAL	
<input type="checkbox"/> Maintain the list of critical infrastructure in the Province of Alberta.	SOLICITOR GENERAL
<input type="checkbox"/> Maintain and regularly test the emergency notification system.	
<input type="checkbox"/> Maintain awareness of threats, vulnerabilities, and risks related to human induced intentional hazards.	
<input type="checkbox"/> Notify Government department of concerns arising from the effects of the incident on critical infrastructure.	
<input type="checkbox"/> Advise other Government departments of modifications to procedures if the incident was intentionally caused.	
<input type="checkbox"/> Provide technical expertise to all stakeholders in the event of an intentional incident and advise appropriate Government officials of potential future targets.	
<input type="checkbox"/> Ensure that effects on critical infrastructure have been resolved.	
<input type="checkbox"/> Recommend changes to critical infrastructure plans to mitigate future events.	

9.3.8 Alberta Pressure Equipment Incidents

ALBERTA BOILERS SAFETY ASSOCIATION	
<input type="checkbox"/> Review, accept and register pressure equipment designs and construction procedures that relate to pressure equipment.	ABSA
<input type="checkbox"/> Issue certification of inspection permits for pressure equipment before the equipment is placed into service.	
<input type="checkbox"/> Ensure that regular inspection of in-service pressure equipment is conducted.	
<input type="checkbox"/> Keep records for pressure equipment that has been registered for use, or manufactured, in Alberta.	
<input type="checkbox"/> Examine, certify and register Pressure Welders and Welding Examiners, Power Engineers, and Pressure Equipment Inspectors.	
<input type="checkbox"/> Authorize and monitor, through quality management system, organizations that have been permitted to conduct some of the activities subject to the regulations.	
<input type="checkbox"/> Conduct safety education and training.	
<input type="checkbox"/> Receive notification of an incident.	
<input type="checkbox"/> Investigate accidents or unsafe conditions that involve pressure equipment.	

Accidents that must be reported include:

- All accidents involving pressure equipment (boiler, pressure vessel, pressure piping system, fitting, or thermal liquid heating system) that result in damage to property or injury to, or death of, a person.
- Accidents not caused by pressure equipment but having some impact on pressure equipment.

Incidents above must be immediately reported to the following:

- The Company's Pressure Equipment Chief Inspector.
- Alberta Boilers Safety Association (ABSA) Office or ABSA Safety Codes Officer. After hours, call the Edmonton Switchboard. The message will provide after-hours phone numbers for contact.

For non-critical incidents, notify the Company's Chief Inspector and ABSA by the next business day. As soon as possible, send a full written report via mail (See ABSA Accident Reporting Form AB-97).

9.3.9 Reporting Electrical Incidents

Section 15 of the Administrative Items Regulation requires that electrical incidents, as well as fires which are suspected to be of an electrical origin, be reported as soon as practicable to the technical Administrator for the electrical discipline: either directly or via a safety codes officer. The regulation also requires that nothing be tampered with at the scene of an incident until a safety codes officer has granted permission and determined whether further investigation is required.

Incidents should be reported to a safety codes officer representing the inspection authority having jurisdiction (i.e. accredited municipality, accredited corporation or Alberta Municipal Affairs for non-accredited areas of the province).

In addition to reporting an electrical incident, Section 48 of the Safety Codes Act also requires that when an incident is investigated, the corresponding investigation report must be submitted to the technical Administrator for the electrical discipline.

9.3.10 List of Abbreviations

Acronym	Name
AAF	Alberta Agriculture and Forestry
ABSA	Alberta Boilers Safety Association
AEMA	Alberta Emergency Management Agency
AER	Alberta Energy Regulator
AHS	Alberta Health Services
AT	Alberta Transportation
CMO	Consequence Management Officer
EPA	Ministry of Environment and Protective Areas
EPEA	Environmental Protection and Enhancement Act
Local Authority	County, Municipal District, Special Areas
MEP	Municipal Emergency Plan
MOH	Medical Officer of Health
PAB	Public Affairs Bureau
PECC	Provincial Emergency Coordination Centre
Regulatory Authority	Alberta Energy Regulator
SOLGEN	Alberta Justice and Solicitor General.

9.4 CANADIAN FEDERAL GOVERNMENT

9.4.1 Royal Canadian Mounted Police (RCMP)

The RCMP is both a federal and a national police force of Canada. The RCMP provides policing services to all of Canada at a federal level, and also on a contract basis to the three territories, eight of Canada's provinces (the RCMP does not provide provincial or municipal policing in either Ontario or Quebec), more than 190 municipalities, 184 Indigenous communities, and three international airports.

RCMP	
<input type="checkbox"/> May assist in the initial area isolation, security traffic and crowd control.	RCMP
<input type="checkbox"/> In conjunction with transportation, local authorities and Company personnel, may provide assistance with closure of roadways.	
<input type="checkbox"/> If available, assist company personnel with resident evacuation.	
<input type="checkbox"/> Clarify responsibilities when fatalities are involved. Police must be notified in the case of a fatality.	
<input type="checkbox"/> Assist the coroner in the event of a fatality in which there is no criminal wrong-doing.	
<input type="checkbox"/> Notify next-of-kin in the event of a fatality of a member of the public.	

9.4.2 Environment and Climate Change Canada

Environment and Climate Change Canada is responsible for coordinating environmental policies and programs as well as preserving and enhancing the natural environment and renewable resources. The powers, duties and functions of the Minister of the Environment extend to and include matters relating to: preserve and enhance the quality of the natural environment, including water, air, soil, flora and fauna; conserve Canada's renewable resources; conserve and protect Canada's water resources; forecast daily weather conditions and warnings, and provide detailed meteorological information to all of Canada; enforce rules relating to boundary waters; and coordinate environmental policies and programs for the federal government.

Under the Canadian Environmental Protection Act (CEPA 1999), Environment and Climate Change Canada is the lead federal department to ensure the clean-up of hazardous waste and oil spills for which the government is responsible, and to provide technical assistance to other jurisdictions and the private sector as required.

ENVIRONMENT AND CLIMATE CHANGE CANADA	
<input type="checkbox"/> Identify actions required under the Fisheries Act and the Canadian Environmental Protection Act (CEPA).	ENVIRONMENT AND CLIMATE CHANGE CANADA
<input type="checkbox"/> Work together with provincial environmental protection agencies.	
<input type="checkbox"/> Provide advice on environmental implications as a result of operational decisions.	
<input type="checkbox"/> Work together with provincial environmental protection agencies.	
<input type="checkbox"/> Assign inspectors where appropriate.	
<input type="checkbox"/> Assist with plume monitoring.	
<input type="checkbox"/> Provide advice on the characteristics of substances and how they might affect human health and environment; weather forecasting and spill modeling to identify where these substances are likely to move in the environment.	
<input type="checkbox"/> Provide sampling and laboratory analytical support.	
<input type="checkbox"/> Advise about clean up technology and techniques.	
<input type="checkbox"/> May develop damage assessment and restoration tools and techniques.	

Canadian Environmental Protection Act (CEPA)

Under the Canadian Environmental Protection Act (CEPA), the Government of Canada is required to take preventive and remedial measures to protect, enhance and restore the environment.

An environmental emergency is defined as an incident that:

1. may have an immediate or long-term harmful effect on the environment or its biological diversity,
2. may constitute a danger to the environment on which human life depends or
3. may constitute a danger in Canada to human life or health.

Any person in Canada who owns or manages a listed substance in a quantity at or over the prescribed minimum quantity is required to provide Environment and Climate Change Canada with information on the quantity of the substance, along with the facility location and an emergency plan. Any existing emergency plan may be used to satisfy the requirements of the regulations.

Environment and Climate Change Canada requires any responsible person who has charge, management or control of substances within a facility in excess of threshold limits listed in Schedule 1 of the Environmental Emergency Regulations to:

- File a declaration with the minister.
- Prepare an environmental emergency (E2) plan.
- Implementation by yearly maintenance and testing of the plan.

Exemptions

- Amounts temporarily stored for 72 hours or less in a container not normally located at the site.
- Quantities in a container with capacity of 30 kg or less.
- Quantities of substance when it is a component of another substance in Schedule 1.
- Quantities of a substance when it is a component of natural gas.
- A substance that is used to fuel a heating appliance or to generate power at the facility where it is located and is present in a quantity that is less than the quantity set out in column 4 or Part 1 of Schedule 1.
- Quantities of a substance in fuel tank supplying engine of conveyance.
- Quantities of a substance regulated under Transportation of Dangerous Goods Act or the Canada Shipping Act.
- A substance that is in a pipeline located entirely within a province and that is on a property where there are no fixed onshore installations other than pipelines, compressor stations or pump stations.

Environmental Emergencies Regulations – Quick Reference

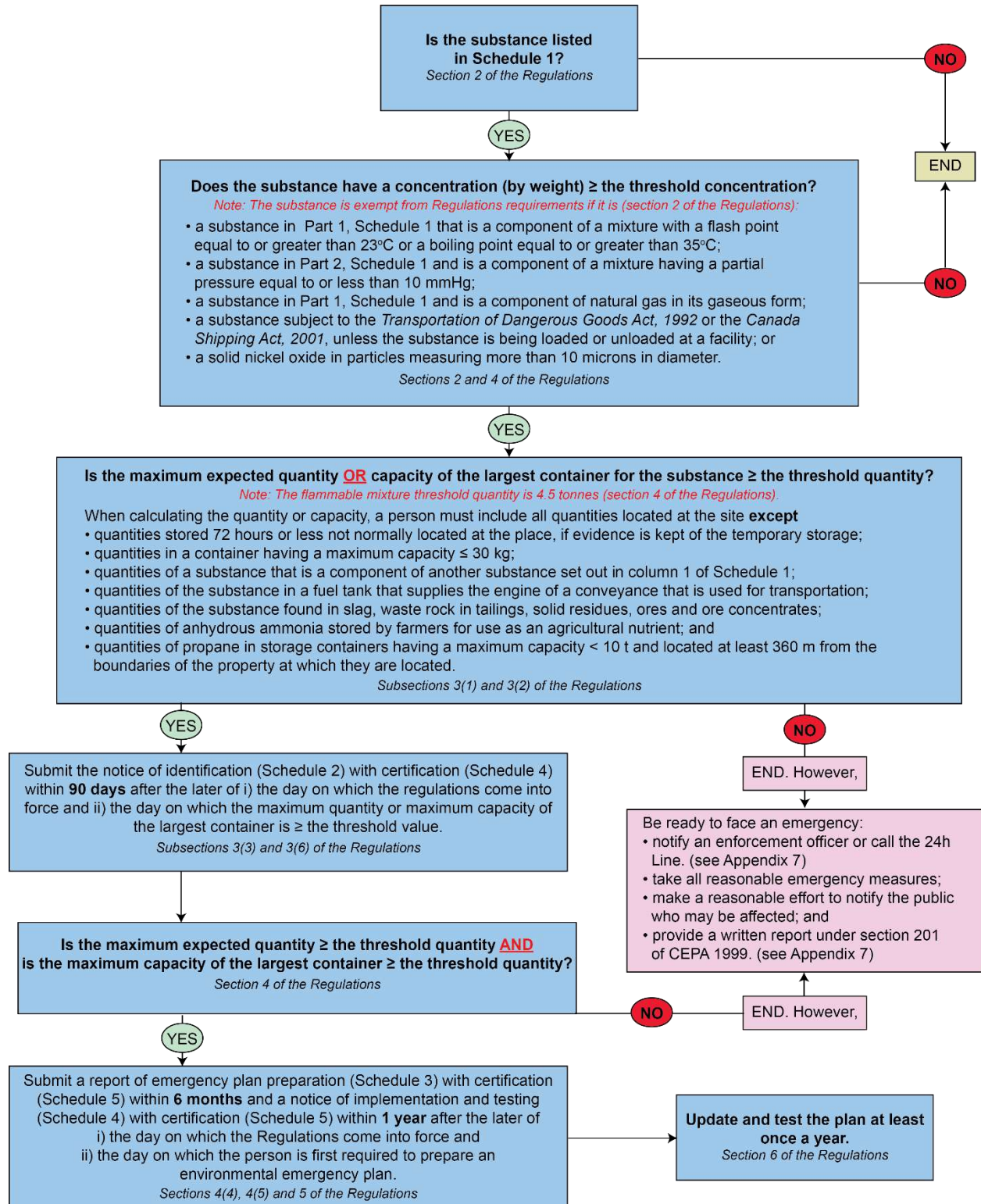

Overview of Environmental Emergency Regulations Schedules

The CEPA schedules can be found via the Environment and Climate Change Canada website.

The schedules submitted by the company should be reviewed during the annual ERP update to ensure all contact and technical information is correct.

Schedule 1 – List of toxic substances

Schedule 2 – Company name and substances located at a facility

Schedule 3 – E2 Plan preparation

Schedule 4 – E2 Plan brought into effect

Schedule 5 – Full Scale Exercise of E2 plan

Schedule 6 – Notice of change in circumstances (quantity or capacity)

Schedule 7 – Notice of cessation of operations or transfer of ownership

Schedule 8 – Written report of environmental emergency

Environmental Emergency (E2) Plan

The objectives of the Environmental Emergency Regulations (2019) under the Canadian Environmental Protection Act, 1999 are to reduce the frequency and consequences of uncontrolled, unplanned or accidental releases of hazardous substances into the environment. The objective is obtained through proper environmental emergency planning so that companies are able to prevent, prepare for, respond to and recover from an environmental emergency.

Essential Features of an Environmental Emergency (E2) Plan

The E2 Plan must address the types of emergencies that might reasonably occur, including both on-site and off-site consequences, and the associated prevention, preparedness, response and recovery issues.

Persons involved with an E2 Plan along with their respective roles and responsibilities will have to be identified in the plan.

Environmental emergency plans may address:

- Prevention
- Preparedness
- Response
- Recovery

Prevention Plan

Preventing environmental emergencies means taking action to reduce or eliminate the environmental risks. The Company recognizes that prevention is by far the most important area for focus.

To qualify as an approved petroleum operator the Company is required to meet strict government standards. These legislated standards govern the construction, maintenance and operations of petroleum assets throughout Canada and help ensure the safe operation of petroleum industry infrastructure, limiting the impact on the public and the environment.

The Company has in place the following key elements of a maintenance program and safety management system:

- The operations are designed and constructed to specific industry standards.
- The Company has preventative maintenance checks and programs that include using: An Owners Inspection Program that meets Boilers Safety Association regulations. This includes a maintenance tracking system to schedule preventative maintenance work.
- The Company is committed to maintaining effective operating procedures and facility documentation.
- Operator competency is reviewed to determine the type and amount of training each employee requires upon hiring.
- Process and procedures are in place to ensure that changes in design, service or staff are effectively managed to minimize impacts on operations.
- Incident investigation and analysis is conducted to minimize reoccurrence of accidents and incidents are tracked through the Company workplace tracking system.
- The Company is committed to conducting regular reviews to assess compliance to standards.

Preparedness Plan

Being prepared for an emergency is critical to mounting a quick and effective response that will help minimize impacts on the health of people and the environment.

The Company's Environmental Emergency Plan will work in partnership with government, other industry members and communities to:

- Identify potential risks and sensitive resource environments.
- Develop contingency plans that outline how to deal with emergencies.
- Train personnel to apply this plan.
- Review and exercise this plan to strengthen their effectiveness and ensure continuous improvement.

The Company has conducted a risk assessment and identified the most reasonable worst-case scenarios to be:

- An uncontrolled release.
- A fire/explosion.

The potential consequences of an emergency may include:

- Negative environmental impact caused by a hazardous substance.
- Serious injury or fatality.

The purpose of an ERP is to establish an action plan structure so that the Company can quickly and effectively respond to an emergency. This ERP outlines the criteria for assessing an emergency situation. The document also lists procedures for mobilizing response personnel (including government agencies) and provides procedures for establishing communication and coordination amongst the vested parties.

Refer to the facilities on-site information/plot plans showing:

- Tanks and vessels.
- Process equipment.
- Worker muster points.
- Safety equipment.
- Fire prevention/protection/suppression/equipment.
- Surface run-off control points and off-lease control points.
- Spill kits.

Facilities also have well marked signs for containers, hazardous substances, operating procedures and site-specific emergency information.

Response Plan

Key sections in this ERP that define the emergency response protocol include:

- Assessment Matrix for Classifying Incidents
- Roles and Responsibilities
- Command Centres
- Crisis Communication Plan
- Response Action Plans

The roles and procedures to carry out response activities are described in the Roles and Responsibilities section of this manual. The Telephone Directory contains government agency and support service contact information who could be involved in the response to an environmental emergency. The stakeholder information in the Field Specific Section identifies members of the public or industry that could be affected by an environmental emergency. Each site-specific section also contains an area summary. The area summary includes pertinent area information that may be relevant during an environmental emergency such as topography, spill receptors, and land use.

When it comes to environmental emergencies, no single organization can do it all. Effective emergency response requires teamwork among industry, governments, communities and local organizations.

Environment and Climate Change Canada's Emergency officers have HAZMAT (Hazardous Materials) expertise, backed by scientific support, which enables response in the event of spills involving hazardous materials. The role of Environment and Climate Change Canada's environmental emergency response team is to provide advice and support on:

- Hazardous material properties, behaviour, fate and environmental effects.
- Spill-behaviour and spill-movement modeling using the latest-generation models and techniques.
- Training in personnel protection at pollution emergencies.
- Advice and direct support on state-of-the-art, on-site monitoring of human and environmental hazard levels at pollution emergencies.
- Sample collection at spill sites.
- The contract administration of airborne services for the remote sensing of spills.
- The evaluation of spill countermeasures, particularly those relating to containment and recovery, treatment and disposal techniques.
- Priority assessment for shoreline protection and clean-up using its Shoreline Clean-up and Assessment Technique (SCAT).

Recovery Plan

It is important to clean-up and recover from environmental damage after an emergency. Environmental damage is the impact pollution causes to the bio-physical environment. It can affect survival, growth, reproduction, behaviour, community composition, ecological process functions, physical and chemical habitat quality and structure. There can also be impacts on socio-economic services.

The two key parts of recovery are environmental damage assessment and restoration. The Company's end goal is to restore the environment after a spill.

The Company will shut-in the impacted facility, assess and respond to the environmental impacts in compliance with regulation. The Company will conduct an assessment of the incident with the appropriate government agencies to decide if the site is safe for operations to continue. The Company will ensure the site is safe for normal work resumption. Workers affected by the incident will be informed of work resumption dates and times. Work resumption, investigation and critical incident stress debriefing procedures are outlined in the Post Emergency section of this manual.

Once the immediate emergency has ended and the initial clean-up has been done, there may be lingering environmental impacts. Recovery activities are designed to examine these possible impacts through damage

assessment. During this phase, the Company will determine the nature and extent of the environmental pollution and develop strategies to restore injured natural resources, ecological service flows and socio-economic service flows.

CEPA Compliance and Enforcement

Environment and Climate Change Canada may request copies of environmental emergency plans. In addition to facility visits by enforcement officers, violations of CEPA Sections 199 and 200 may result in warnings, directions, compliance orders, and prosecution.

Environmental Emergencies Program

The Environmental Emergencies Program protects Canadians and their environment from the effects of environmental emergencies through the provision of science-based expert advice and regulations. The Environmental Emergencies Program provides expert advice during the environmental assessment process of large development projects to improve mitigation measures that prevent accidents from occurring and improve emergency response plans so that effective and timely actions can be taken when accidents occur.

Note: The Federal government and Provinces have reciprocal harmonization agreements to share information as required to protect human life, health and environmental protection.

Who to Contact:

Province	Agency
Alberta	Alberta Ministry of Environment and Parks
British Columbia	Emergency Management British Columbia – Ministry of Justice
Saskatchewan	Saskatchewan Ministry of Environment
Manitoba	Manitoba Agriculture and Resource Development – Petroleum Branch

9.4.3 Department of Fisheries and Oceans (DFO)

The department within the government of Canada that is responsible for developing and implementing policies and programs in support of Canada's economic, ecological and scientific interests in oceans and inland waters. Its mandate includes responsibility for the conservation and sustainable use of Canada's fisheries resources while continuing to provide safe, effective and environmentally sound marine services that are responsive to the needs of Canadians in a global economy.

Any amount of hydrocarbons entering a waterway frequented by fish or occupied by waterfowl is deemed to be in contravention of the Federal Fisheries Act and must be reported to the Department of Fisheries and Oceans.

DEPARTMENT OF FISHERIES AND OCEANS	
<input type="checkbox"/> Design and develop related regulations, policies, strategies and tools.	DFO
<input type="checkbox"/> Review, assess and monitor activities associated with fish habitat to ensure their compliance with the Fisheries Act and Species at Risk Act.	
<input type="checkbox"/> Conduct environmental assessments under the Canadian Environmental Assessment Act.	
<input type="checkbox"/> Design, develop, and implement communication and education strategies.	
<input type="checkbox"/> Work together with provincial environment protection agencies.	
<input type="checkbox"/> Receive notification from Environment and Climate Change Canada.	
<input type="checkbox"/> May send personnel to the site if there has been or could potentially be an impact to fish or fish habitat.	
<input type="checkbox"/> Work closely with Environment and Climate Change Canada, The Canadian Coast Guard and other provincial environmental agencies.	

9.4.4 Public Safety Canada

Public Safety Canada formerly known as Public Safety and Emergency Preparedness Canada, legally incorporated as the federal Department of Public Safety and Emergency Preparedness, is the department of the government of Canada with responsibility for protecting Canadians and helping to maintain a peaceful and safe society.

Public Safety Canada houses the Government Operations Centre at the hub of the national emergency management system. The Government Operations Centre is an advanced centre for monitoring and coordinating the federal response to an emergency.

In the event of a large-scale natural disaster where response and recovery costs exceed what individual provinces and territories could reasonably be expected to bear on their own, Public Safety Canada provides financial assistance to the provincial and territorial governments through the Disaster Financial Assistance Arrangements (DFAA). Assistance is paid to the province or territory – not directly to individuals or communities. The provincial or territorial governments design, develop, and deliver disaster financial assistance, determining the amounts and types of assistance that will be provided to those who have experienced losses.

PUBLIC SAFETY CANADA	
<input type="checkbox"/> Ensure first responders and emergency management personnel are well-prepared through education, support, and exercises.	PUBLIC SAFETY
<input type="checkbox"/> Work with provincial response agencies.	
<input type="checkbox"/> Monitor and coordinate the Federal response to an emergency.	
<input type="checkbox"/> Provide financial assistance to the provincial and territorial governments through the Disaster Financial Assistance Arrangements (DFAA).	

9.4.5 Transport Canada – Transportation of Dangerous Goods

The department within the government of Canada which is responsible for developing regulations, policies and services of transportation in Canada. It is part of the Transportation, Infrastructure and Communities (TIC) portfolio. The federal Transportation of Dangerous Goods (TDG) Regulations regulate the transportation of dangerous goods for the road, rail, air and marine transport modes.

The purpose of the TDG legislation is to reduce the risk to emergency response personnel, the public and the environment. One secondary objective is to collect data on accidents which involve dangerous goods either directly or indirectly. This data will allow the measurement of the influence of this legislation on safety.

The Surface Transport Dangerous Goods Directorate of Transport Canada may assume federal Lead Agency status for land-based spills involving rail cars or tank trucks. It also administers and enforces the requirements of the Transportation of Dangerous Goods (TDG) Act following a transportation emergency incident.

The Marine Safety Branch also administers and enforces the pollution provisions and regulations of the Canada Shipping Act (CSA) and has the legal authority to board vessels, draw samples, and collect evidence. This work is performed by an authorized Pollution Prevention Officer.

Transport Canada also staffs and manages the Canadian Transport Emergency Centre (CANUTEC) which provides 24-hour advice on chemical spill response, TDG requirements, and also serves as a 24-hour emergency reporting centre for hazardous materials incidents anywhere in Canada. The Directorate’s overall mandate is to promote public safety in the transportation of dangerous goods by all modes.

Federal regulations require that CANUTEC be contacted in the event of an incident or accident involving dangerous goods and infectious substances.

CANUTEC staff does not go to the site of an incident, however, should on-site assistance be required, CANUTEC can assist in the implementation or industry Emergency Response Assistance Plans.

TRANSPORT CANADA	
<input type="checkbox"/>	Regulate the handling, offering for transport and the transport of dangerous goods by all modes in order to ensure public safety.
<input type="checkbox"/>	Maintain a 24-hour emergency telephone service.
<input type="checkbox"/>	Assist emergency response personnel in handling dangerous good emergencies.
<input type="checkbox"/>	Provide advice on chemical, physical and toxicological properties and incompatibilities of the dangerous goods.
<input type="checkbox"/>	Provide advice on health, hazards, and first aid.
<input type="checkbox"/>	Provide advice on fire, explosion, spill, or leak hazards.
<input type="checkbox"/>	Provide advice on remedial actions for the protection of life, property, and the environment.
<input type="checkbox"/>	Provide advice on evacuation distances.
<input type="checkbox"/>	Provide advice on personal protective clothing and decontamination.
<input type="checkbox"/>	Provide communication links with the appropriate industry, government, or medical specialists.

TRANSPORT CANADA

CANUTEC – Public Safety Measures

CANUTEC is the Canadian Transport Emergency Centre operated by the Transportation of Dangerous Goods (TDG) Directorate of Transport Canada. The Directorate's overall mandate is to promote public safety in the transportation of dangerous goods by all modes. CANUTEC was established in 1979 and is one of the major safety programs Transport Canada delivers to promote the safe movement of people and goods throughout Canada.

The 2024 Emergency Response Guidebook (ERG2024) was developed, in an international effort between Argentina, Canada, Mexico and the United States for use by fire fighters, police, and other emergency services personnel who may be the first to arrive at the scene of a transportation incident involving dangerous goods. It is primarily a guide to aid first responders in quickly identifying the specific or generic hazards of the material(s) involved in the incident and protecting themselves and the general public during the initial response phase of the incident. For the purposes of the ERG2024, the "initial response phase" is that period following arrival at the scene of an incident during which the presence and/or identification of dangerous goods is confirmed, protective actions and area securement are initiated, and assistance of qualified personnel is requested. It is not intended to provide information on the physical or chemical properties of dangerous goods.

The ERG2024 is designed to assist responders in making initial decisions upon arriving at the scene of a dangerous goods incident. It should not be considered as a substitute for emergency response training, knowledge or sound judgment. ERG2024 does not address all possible circumstances that may be associated with a dangerous goods incident. It is primarily designed for use at a dangerous goods incident occurring on a highway or railroad. Be mindful that there may be limited value in its application at fixed facility locations.

In the event of an emergency involving dangerous goods, call CANUTEC at 1-888-CAN-UTEC (226-8832), 613-996-6666 or *666 on a cellular phone. CANUTEC's emergency response advisors provide immediate advice over the phone about the actions to take and to avoid during a dangerous goods emergency. They can also send technical information to local authorities responsible for responding to emergencies by email or fax during an incident.

ID No.	Guide No.	Name of Material	Public Safety (Immediate precautionary measures)	Evacuation						
				Large Spill	Fire					
1971	115	<ul style="list-style-type: none"> Methane Methane, compressed Natural gas, compressed 	100 m (330 ft)	Consider initial downwind evacuation for at least 800 metres (1/2 mile)						
1075	115	<ul style="list-style-type: none"> Butane Liquefied Petroleum Gas (LPG) Propane Propane mixture 	100 m (330 ft)	Consider initial downwind evacuation for at least 800 metres (1/2 mile)						
1071	119	<ul style="list-style-type: none"> Oil gas Oil gas, compressed 	100 m (330 ft)	Increase, in the downwind direction, as necessary, the isolation distance shown under "PUBLIC SAFETY".						
1267	128	<ul style="list-style-type: none"> Petroleum crude oil 	50 m (150 ft)	Consider initial downwind evacuation for at least 300 metres (1000 ft).						
1114	130	<ul style="list-style-type: none"> Benzene 	50 m (150 ft)	Consider initial downwind evacuation for at least 300 metres (1000 ft).						
ID No.	Guide No.	Name of Material	Public Safety (Immediate precautionary measures)	Initial Isolation and Protective Action Distances					Fire	
				Small Spills			Large Spills			
				First Isolate in all directions	Then protect persons downwind during		First Isolate in all directions	Then protect persons downwind during		
Day	Night	Day	Night							
1053	117	<ul style="list-style-type: none"> Hydrogen Sulphide 	100 m (330 ft)	30 m	0.1 km	0.4 km	400 m	2.1 km	5.4 km	If tank, rail car or tank truck is involved in a fire, ISOLATE for 1600 meters (1 mile) in all directions; also, consider initial evacuation for 1600 meters (1 mile) in all directions.
3494	131	<ul style="list-style-type: none"> Petroleum sour crude oil, flammable, toxic 	50 m (150 ft)	30 m	0.1 km	0.2 km	60 m	0.5 km	0.7 km	If tank, rail car or tank truck is involved in a fire, isolate for 800 metres (1/2 mile) in all directions; also, consider initial evacuation for 800 metres (1/2 mile) in all directions.
1017	124	<ul style="list-style-type: none"> Chlorine 	100 m (330 ft)	60 m	0.3 km	1.1 km	See table below		If tank, rail car or tank truck is involved in a fire, isolate for 800 metres (1/2 mile) in all directions.	

Toxic Inhalation Hazardous Materials	Transport Container	First ISOLATE in all Directions	Initial Isolation and Protective Action Distances					
			Day			Night		
			Low wind < 6 mph = < 10 km/h	Moderate wind 6-12 mph = 10 - 20 km/h	High wind > 12 mph = > 20 km/h	Low wind < 6 mph = < 10 km/h	Moderate wind 6-12 mph = 10 - 20 km/h	High wind > 12 mph = > 20 km/h
Chlorine (UN 1017) Sulphur Dioxide (UN 1079)	Rail Tank Car	1000 m (3000 ft)	9.9 km (6.2 mi)	6.4 km (4.0 mi)	5.1 km (3.2 mi)	11+ km (7+ mi)	9.0 km (5.6 mi)	6.7 km (4.2 mi)
	Highway tank truck or trailer	600 m (2000 ft)	5.8 km (3.6 mi)	3.4 km (2.1 mi)	2.9 km (1.8 mi)	6.7 km (4.3 mi)	5.0 km (3.1 mi)	4.1 km (2.5 mi)
	Multiple ton cylinders	300 m (1000 ft)	2.1 km (1.3 mi)	1.3 km (0.8 mi)	1.0 km (0.6 mi)	4.0 km (2.5 mi)	2.4 km (1.5 mi)	1.3 km (0.8 mi)
	Multiple small cylinders or single ton cylinder	150 m (500 ft)	1.5 km (0.9 mi)	0.8 km (0.5 mi)	0.5 km (0.3 mi)	2.9 km (1.8 mi)	1.3 km (0.8 mi)	0.6 km (0.4 mi)

Emergency Response Guidebook

U.S. Department of Transportation, Pipeline and Hazardous Materials Safety Administration, Transport Canada, Secretariat of Transport and Communications, 2024

Reporting Requirements

The Transportation of Dangerous Goods Act, 1992 (TDG Act) requires reporting dangerous goods incidents which meet or exceed established reporting criteria listed in the Transportation of Dangerous Goods Regulations (TDG Regulations).

Who should report:

The report must be made by the person who has the charge, management or control of a means of containment (e.g. a driver, a company representative, a shipmaster, a train operator etc.) at the time of the incident if the release or anticipated release (e.g. spills, accidents), loss or theft of dangerous goods that is or could be in excess of a quantity or concentration specified by regulation from the means of containment if it endangers, or could endanger, public safety.

When to report:

Part 8 of the TDG Regulations (Reporting Requirements) requires a number of different report types. When certain conditions are met, persons subject to the TDG Regulations must submit one of the report types below.

Reports for the Transport of Dangerous Goods by Road, Rail and Marine

- Emergency Report – Road, Rail or Marine (Section 8.2 of the TDG Regulations)
- Release or Anticipated Release Report – Road, Rail or Marine (Section 8.4 of the TDG Regulations)
- 30-Day Follow-Up Report (Section 8.6 of the TDG Regulations)

Reports for the Transport of Dangerous Goods by Air

- Dangerous Goods Accident or Incident Report — Air (Section 8.9 of the TDG Regulations)
- 30-Day Follow-up Report (Section 8.11 of the TDG Regulations)
- Undeclared or Mis-declared Dangerous Goods Report (Section 8.14 of the TDG Regulations)

Reports Relating to Security – All Modes of Transport

- Loss or Theft Report (Section 8.16 of the TDG Regulations)
- Unlawful Interference Report (Section 8.18 of the TDG Regulations)

Emergency Report – Road, Rail or Marine Transport

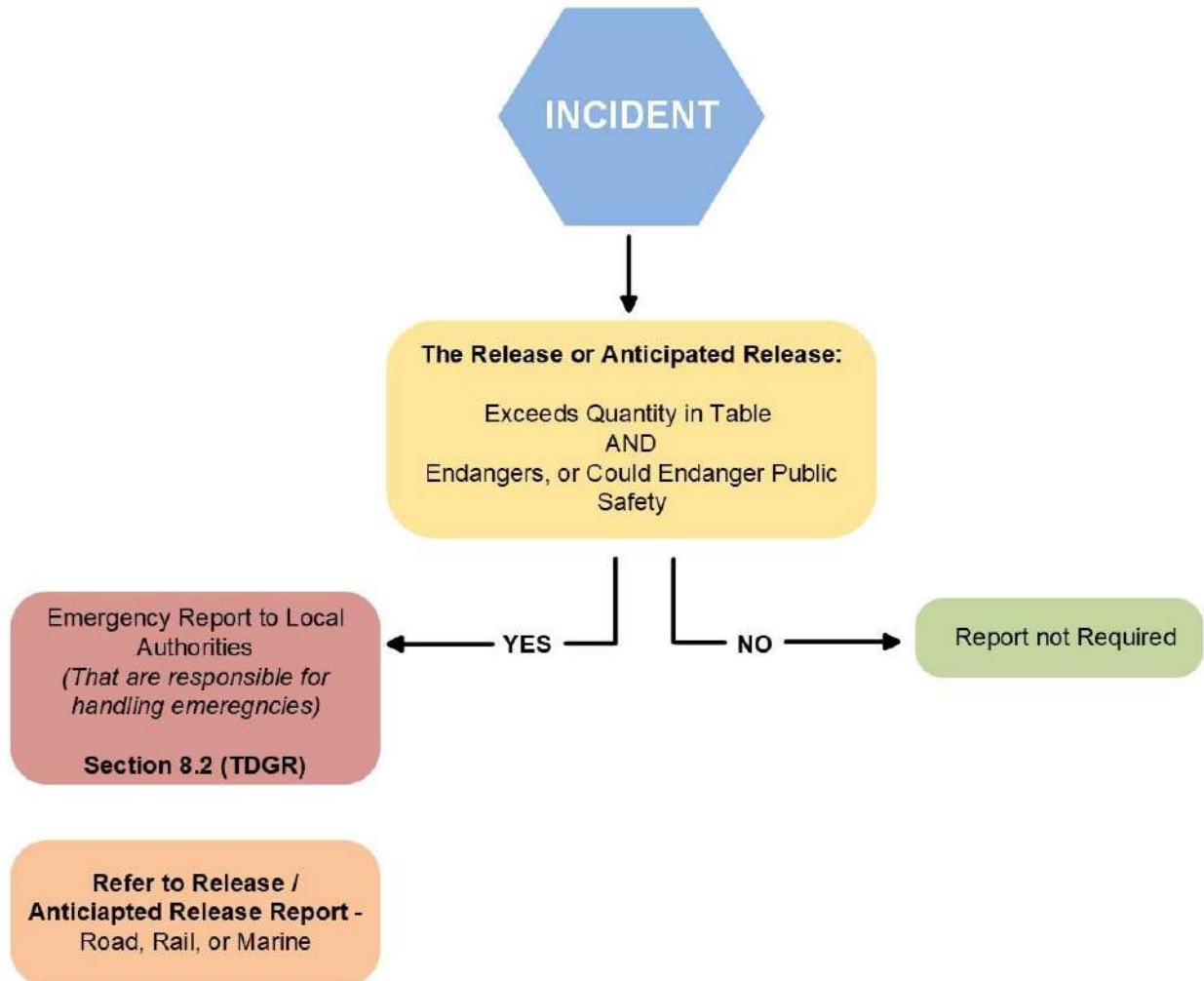

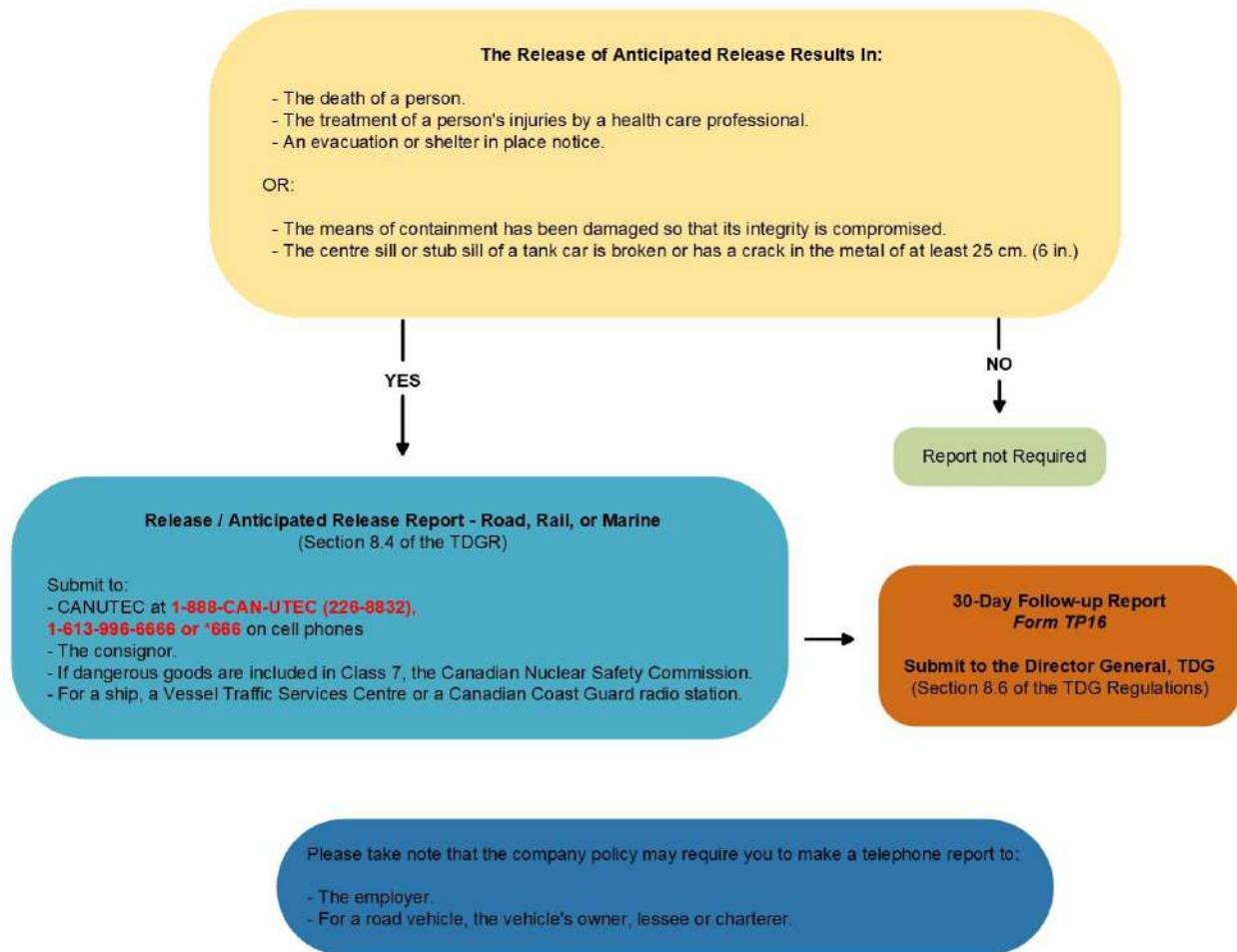

Transportation of Dangerous Goods ERAP

The TDG Act requires any person importing or offering for transport certain higher risk dangerous goods (for example chlorine, propane, crude oil) in quantities specified by the TDG Regulations to have an approved Emergency Response Assistance Plan (ERAP) and ERAP number.

The ERAP number is found on the shipping document. If you call the ERAP telephone number, you will be connected with someone who can implement the plan. They will: provide technical and/or emergency response advice promptly.

An ERAP describes what to do in the event of a release or anticipated release of certain higher-risk dangerous goods while they are in transport. The plan is intended to assist local emergency responders by providing them with technical experts and specially trained and equipped emergency response personnel at the scene of an incident.

ERAPs may be used along with emergency response plans from other organizations (for example, carriers and local or provincial authorities). An incident management system, usually the Incident Command System (ICS), ensures coordination between the ERAP and other emergency response plans.

9.4.6 Transportation Safety Board

The Transportation Safety Board of Canada (TSB) has a mandate to advance transportation safety in the marine, pipeline, rail and air modes of transportation.

The CER and the TSB have adopted a single window reporting approach for inter-provincial or cross border pipelines. The new Online Event Reporting System (OERS) automates the single-window pipeline occurrence notification process that was established by the TSB and the CER.

Roles and Responsibilities

TRANSPORTATION SAFETY BOARD	
<input type="checkbox"/>	Conduct independent investigations, including public inquiries when necessary, into selected transportation occurrences in order to make findings as to their causes and contributing factors.
<input type="checkbox"/>	Identify safety deficiencies, as evidenced by transportation occurrences.
<input type="checkbox"/>	Make recommendations designed to eliminate or reduce any such safety deficiencies.
<input type="checkbox"/>	Report publicly on their investigations and on the findings in relation thereto.

TSB

TSB Pipeline Occurrence Reporting

Requirement to Report

A "pipeline occurrence" must be reported if it results directly from the operation of the pipeline, where

1. a person is killed or sustains a serious injury;
2. the safe operation of the pipeline is affected by
 1. damage sustained when another object came into contact with it, or
 2. a fire or explosion or an ignition that is not associated with normal pipeline operations;
3. an event or an operational malfunction results in
 1. an unintended or uncontrolled release of gas,
 2. an unintended or uncontrolled release of HVP hydrocarbons,
 3. an unintended or uncontained release of LVP hydrocarbons in excess of 1.5 m³, or
 4. an unintended or uncontrolled release of a commodity other than gas, HVP hydrocarbons or LVP hydrocarbons;
4. there is a release of a commodity from the line pipe body;
5. the pipeline is operated beyond design limits or any operating restrictions imposed by the Canada Energy Regulator;
6. the pipeline restricts the safety operation of any mode of transportation;
7. an unauthorized third-party activity within the safety zone poses a threat to the safe operation of the pipeline;
8. a geotechnical, hydraulic or environmental activity poses a threat to the safe operation of the pipeline;
9. the operation of a portion of the pipeline is interrupted as a result of a situation or condition that poses a threat to any person, property or the environment; or
10. an unintended fire or explosion has occurred that poses a threat to any person, property or the environment.

Input the information you have as soon as possible after the occurrence

As soon as possible after the occurrence, enter the information you have about it into the Online Event Reporting System (OERS). When the information is submitted, the OERS will automatically notify the TSB and the CER.

Information must be entered in the OERS even if you have reported the occurrence by telephone.

Enter factual information only. Information that is considered a witness statement and/or personal information must not be entered in the OERS.

Submit additional information as soon as available

Provide the remainder of the information required by the TSB through the OERS as soon as it becomes available and no later than 30 days after the occurrence.

If you have any questions or concerns about using the Online Event Reporting System for reporting occurrences to the TSB, call the TSB.

9.4.7 Health Canada

Health Canada is the department of the Government of Canada with responsibility for national public health.

HEALTH CANADA		HEALTH CANADA
<input type="checkbox"/>	Communicates information about health and wellness and disease prevention to protect Canadians from avoidable risks.	
<input type="checkbox"/>	During a health emergency or disaster, Health Canada and the Public Health Agency of Canada are responsible for supporting emergency health and social services in the provinces and territories.	
<input type="checkbox"/>	Work collaboratively with the provinces and territories to test ways in which the Canadian health care system can be improved and ensure its sustainability for the future.	

9.4.8 Public Health Agency of Canada

Public Health Agency of Canada is an agency of the Government of Canada that is responsible for public health, emergency preparedness, and response and infectious and chronic disease control and prevention.

In an emergency situation, the Office of Emergency Response Services (OERS) is responsible for supporting emergency health and social services in the provinces, territories, or abroad. It manages the National Emergency Stockpile System (NESS), which includes medical, pharmaceutical and related emergency supplies.

PUBLIC HEALTH AGENCY OF CANADA		PUBLIC HEALTH
<input type="checkbox"/>	Facilitate national approaches to public health policy and planning.	
<input type="checkbox"/>	If a public health emergency grows beyond one province and/or territory activate response actions.	
<input type="checkbox"/>	Deploy health emergency response teams (HERT) as part of the federal response to emergencies that have health repercussions.	
<input type="checkbox"/>	Work with Health Canada to test ways in which the Canadian health care system can be improved and ensure its sustainability for the future.	

9.4.9 Indigenous Services Canada (ISC)

The department of the Government of Canada with responsibility for policies relating to Indigenous peoples in Canada, that comprise the First Nations, Inuit, and Metis.

INDIGENOUS SERVICES CANADA		ISC
<input type="checkbox"/>	Ensure that the First Nation communities have emergency management services comparable to those of Canadian in similar situations.	
<input type="checkbox"/>	Work to establish an all-hazard approach for responding to emergencies that impact First Nation communities.	
<input type="checkbox"/>	Mitigation of the effects of emergencies on First Nations reserves for which the department has legal responsibility, including arrangements for community evacuation, temporary shelter, and provision of territorial support.	
<input type="checkbox"/>	Coordination of federal assistance and response to emergencies in response to requests from territorial government authorities.	
<input type="checkbox"/>	Provide funding to cover costs related to emergency assistance in First Nations communities.	
<input type="checkbox"/>	Mitigate the effects of an emergency on First Nationals people in the area.	
<input type="checkbox"/>	Work with the Chief and Council to assess the situation, determine the most effective way to report damage.	
<input type="checkbox"/>	Work with the Chief and Council to assess the situation, determine the most effective way to repair damage and ensure delivery of programs and services to the community.	

9.4.10 Indian Oil and Gas Canada

Indian Oil and Gas Canada's (IOGC) mandate is to further First Nation initiatives to manage and control their oil and gas resources (i.e. governance).

According to the Indian Oil and Gas Regulations, every operator must adhere to all provincial laws applicable to non-Indian lands. This includes the environment, exploration, development, treatment, conservation or equitable production of oil and gas and that are not in conflict with the (Indian Oil and Gas) Act or Regulations.

Note: First Nations reserves and Métis settlements within the EPZ are considered to be local authorities and are required to be notified and consulted as a local authority.

Indian Oil and Gas Spill Reporting Regulations

Indian Oil and Gas Canada, the First Nation and the provincial authority must be notified immediately in the event of any health or environment-threatening emergency or off-lease spills on First Nation reserve lands. On-lease spills greater than 1 m³ must be reported to Indian Oil and Gas Canada (IOGC) immediately.

9.4.11 ERAC – A Not-For Profit Organization

Emergency Response Assistance Canada (ERAC) is a not-for-profit corporation created by industry for industry and is a subsidiary of the Canadian Propane Association (CPA). As a co-operative emergency preparedness and response organization, ERAC is instrumental in assisting hundreds of industry and transportation organizations requiring Emergency Response Assistance Plans (ERAPs).

ERAC's Emergency Response Assistance Plan (ERAP) provides emergency response support to road, rail and stationary tank incidents for vessels.

ERAC Response TDG (ERAP) and CEPA (E2)

ERAC's emergency responders are available 24/7 through their Emergency Call Centre (ECC) telephone number.

When the ECC number has been called, the Emergency Call Centre Operator (ECCO) connects with a Home Base Coordinator (HBC) to provide details on the incident. The HBC assesses the situation based on the information provided and then determines the closest Remedial Measures Advisor (RMA) or Technical Advisor (TA) to be sent to the scene of the emergency. A response team may be dispatched if necessary. If your company is involved in an emergency, the HBC will contact you for permission to implement the plan.

Home Base Coordinator

The Home Base Co-ordinator (HBC) performs the vital function of keeping the ECCO, RMA's, TA's response teams once they assess the situation based on the information that is provided by the ECCO. Their role then throughout is provide constant communication to your company designate(s). This starts from the moment ERAC gets the call and continues until the emergency has been handled successfully. If your company is involved in an emergency, the HBC will contact you for permission to activate the plan.

Remedial Measures Advisors and Technical Advisors – First on the scene

Once the RMA or Technical Advisor is determined which is based on geographic location to the incident the arrival time is an estimated 6 hours or less from the original callout to being on-site. Once at scene this role provides technical and product subject matter expertise by providing advice and assistance in handling the incident. In some instances, they may also conduct minor repairs.

Response Teams – Hand on expertise

These teams will be activated if necessary and dispatched through the HBC. Once activated they'll bring all necessary equipment and expertise to perform remedial measures. ERAC emergency responders are experts in initial containment, confinement, transferring, flaring products and purging LPG and flammable liquids containers.

ERAP Response

Who completes the following tasks, the Plan Participant and/or the ERAC?

Question	Answer
1. Secure accident site upon arrival?	ERAC
2. Call ERAC to advise of Incident by phone and take direction from Home Base Co-ordinator?	Plan Participant
3. Conduct site assessment to identify hazards?	ERAC
4. Implement emergency response procedures as outlined in the ERAP?	ERAC
5. Conduct formal accident assessment (including inspect damaged transport vehicle, etc.)?	ERAC
6. Notify appropriate regulatory authorities? Answer: Person(s) in care and control e.g. Trucker.	Plan Participant
7. Contact local residents?	Plan Participant
8. Transfer dangerous goods from damaged containment?	ERAC
9. Responsible for obtaining and providing the recovery means of containment (e.g. Truck tank(s) or Rail car(s))?	Plan Participant
10. Person (s) responsible for any communications e.g. Media, public, corporate?	Plan Participant
11. Provides transportation to incidents which cannot be accessed by land. (e.g. barge offshore)?	Plan Participant

ERAP Tiered response levels

Two response tiers are based on the level of response needed to address the release or anticipated release of dangerous goods.

A person who implements an ERAP to tier 1 must:

- provide technical or emergency response advice as soon as possible after a request for advice; and
- remotely monitor the response to the release or anticipated release.

A person who implements an ERAP to tier 2 must:

- provide technical or emergency response advice as soon as possible after a request for advice;
- monitor the response to the release or anticipated release; and
- send ERAP emergency response resources to the location of the release or anticipated release.

ERAP implementation report

Each time an ERAP is implemented to tier 1 or tier 2, an ERAP implementation report must be made by the person listed in the ERAP to the Canadian Transport Emergency Centre (CANUTEC) at 1-888-CANUTEC (1-888-226-8832) or 613-996-6666 as soon as possible.

ERAP Response Parameters

As Canada's emergency preparedness and response organization, ERAC assists Plan Participant members who transport specified products by road or rail, or those who store these products in tanks with capacities of 450 litres or greater.

9.5 CANADA ENERGY REGULATOR

The Canada Energy Regulator (CER) is an independent federal agency established to regulate international and interprovincial aspects of the oil, gas and electric utility industries.

CER-regulated companies have the primary responsibility for ensuring safety and environmental protection because they are the owners, designers, builders and operators of the facilities. The CER recognizes this responsibility in the ongoing development of goal-oriented regulation that places the onus on companies to ensure their facilities are safe and secure and are operated in an environmentally responsible manner. The CER plays a significant role by ensuring that the companies maintain or improve their safety and environmental performance. The CER ensures that companies:

- Identify and manage the potential hazards associated with their facilities and operations.
- Conduct a risk analysis of those hazards.
- Eliminate, reduce and manage the risks in order to protect the public and regulated company personnel, the safety and security of the facilities and operations, and the protection of property and the environment.

All companies under the CER's jurisdiction are responsible for developing and maintaining an Emergency Response and Preparedness Program generically referred to as "Emergency Management Program" for all aspects of their operations. In the event an emergency occurs, the regulated company is responsible for responding to the emergency and coordinating emergency response activities.

- That result in death or serious injury.
- Involve a significant release of hydrocarbons.
- Could result in potential or real impact due to loss of service.
- Attract significant media attention.
- On the advice of Natural Resources Canada (NRCan) or other federal Agencies.

All inter-provincial and cross border pipelines are regulated by the CER and require an Emergency Response Plan. To fully comply with the CER Onshore Pipeline Regulations (OPR) and meet CER expectations for an effective emergency preparedness program, NorthRiver is required to have an emergency procedures section for the field operations and conduct emergency response training and exercises.

9.5.1 Contact Information

All incidents, accidents and occurrences as defined by the Onshore Pipeline Regulations (OPR), the Canada Labour Code, and the Transportation Safety Board (TSB) Regulations should be reported.

CALL
For emergencies involving inter-provincial or cross border pipelines, the CER is the Regulatory Authority. In the event of a CER regulated pipeline emergency, call the TSB's 24-hour hotline (collect calls accepted). The TSB will contact the CER to notify them of the incident.
1-819-997-7887

ONLINE REPORTING
Report all events on the CER's Online Event Reporting System. This system is intended for use by regulated companies to provide notification to the Canada Energy Regulator (CER) and Transportation Safety Board (TSB) of various events that are defined in regulation including incidents, unauthorized activities, and operations and maintenance activities.
https://apps.cer-rec.gc.ca/ers/home/index

9.5.2 Roles and Responsibilities

CANADA ENERGY REGULATOR	CANADA ENERGY REGULATOR
<input type="checkbox"/> Monitors, observes and assesses the overall effectiveness of the company's emergency response in terms of: <ul style="list-style-type: none"> • Emergency Management • Safety • Security • Environment • Integrity of operations and facilities, and • Energy Supply. 	
<input type="checkbox"/> Investigates the event, either in cooperation with the Transportation Safety Board of Canada, under the Canada Labour Code, or as per the Canada Energy Regulator Act or Canada Oil & Gas Operations Act (whichever is applicable).	
<input type="checkbox"/> Inspects the pipeline or facility.	
<input type="checkbox"/> Examines the integrity of the pipeline or facility.	
<input type="checkbox"/> Requires appropriate repair methods are being used.	
<input type="checkbox"/> Requires appropriate environmental remediation of contaminated areas is conducted.	
<input type="checkbox"/> Coordinate stakeholders and Indigenous community feedback regarding environmental clean-up and remediation.	
<input type="checkbox"/> Confirms that a company is following its Emergency Procedures Manual(s), commitments, plans, procedures, and CER regulations and identifies non-compliances.	
<input type="checkbox"/> Approves the restart of the pipelines.	

9.5.3 CER Definitions of Incident and Emergency

Incident

Incidents and releases reportable to the CER under sections 1 and 52 of the OPR are:

- The death of or serious injury to a person.
- A significant adverse effect on the environment.
- Unintended fire or explosion.
- Unintended or uncontained release of low-vapour pressure (LVP) hydrocarbons in excess of 1.5 m³.
- Unintended or uncontained release of gas or high-vapour pressure (HVP) hydrocarbons.
- Operation of a pipeline beyond its design limits as determined under CSA Z662, CSA Z276 or any operating limits imposed by the CER.

Although incidents are defined in the OPR, it is also necessary for companies to have a clear understanding of what constitutes incidents and emergencies at their facilities, as well as methods or procedures for determining the magnitude and levels of an emergency as circumstances change.

Emergency

Can/CSA – Z731 and CSA Z246 defines an emergency as “a present or imminent event that requires prompt co-ordination of actions or special regulation of persons or property to protect the health, safety or welfare of people or to limit damage to property and the environment”.

Companies must consider all probable emergencies and have applicable procedures in place to deal with potential effects and treats to people, property and the environment, as determined through a formal hazard assessment.

Level 1	Level 2	Level 3
<ul style="list-style-type: none"> • No effects outside company property • Control of Hazardous substance completed or pending • No immediate threat to the public or company personnel • Minimal environmental effects • Incident/Spill handled by company personnel • Low potential to escalate 	<ul style="list-style-type: none"> • No immediate threat outside company property but potential exists to extend beyond property boundaries • Outside services and government agencies likely to be directly involved • Imminent control of hazardous substance probable • Some injury or threat to the public and company personnel • Moderate environmental effects 	<ul style="list-style-type: none"> • Serious injury to the public and company personnel and ongoing threat to the public • Uncontrolled release of hazardous substance continuing • Significant and ongoing environmental effects • Immediate and significant government agency involvement • Assistance from outside parties required • Effects extend beyond company property

9.5.4 CER Event Reporting

The task of completing the notifications will be completed by the Company's CEOC Liaison Officer.

The Transportation Safety Board of Canada (TSB) has the option to choose to be the lead investigator for determining the cause and contributing factors leading to an incident/ emergency.

For the CER's Event Reporting Guidelines, please refer to the following:

Canada Energy Regulator Event Reporting Guidelines Revised October 2020

Precautionary Approach

It is the CER's expectation that each company take a precautionary approach to the reporting of events. This means that even if there is some doubt as to whether an event should be reported, the company is to report the event. In other words, companies should adopt a "when in doubt, report" approach. This approach to event reporting is consistent with CER-regulated companies' responsibility for anticipating, preventing, mitigating and managing incidents of any size or duration.

The CER's Online Event Reporting System (OERS) now contains a field where the company must indicate that it is reporting an incident on a precautionary basis. In these cases, the CER will determine whether the incident is reportable based on information provided by the company. In cases where an event was reported using the precautionary approach and subsequent information indicates that it was not reportable, the CER records will reflect this and the event will not be included on the company's compliance record and will not be posted on the CER Interactive Incident Map.

Immediately Reportable Events

Where regulations require an event to be reported "immediately", companies must also consider whether the event meets any of the following definitions:

- An Incident that Harms People or the Environment:
 - a death;
 - a serious injury (as defined in the OPR or TSB regulations);
 - an unintended or uncontrolled LVP hydrocarbon release in excess of 1.5 m³ that leaves company property or occurs on or off the right of way;
 - an unintended or uncontrolled sweet natural gas or HVP release >30,000 m³;
 - any unintended or uncontrolled release of sour natural gas or hydrogen sulfide; and/or
 - a significant adverse effect on the environment.
- A Rupture:
 - an instantaneous release that immediately impacts the operation of a pipeline segment such that the pressure of the segment cannot be maintained.
- A Toxic Plume:
 - a band of service fluid or other contaminant (e.g. hydrogen sulfide or smoke) resulting from an incident that causes people, including employees, to take protective measures (e.g. muster, shelter-in-place or evacuation).

Where an event meets any of the above definitions, companies are required to notify the TSB Reporting Hotline at **1-819 997-7887**. Subsequently, the company is required to input the details required by both the TSB and the CER into the OERS. The phone notification and the input of information into OERS are required to occur **as soon as possible and no later than three hours** of the incident being discovered. The goal of the initial phone notification is to allow the relevant agencies to mobilize a response to an incident, if required. Note that OERS will automatically determine whether the event meets the definition of an “Incident that Harms People or the Environment”, however the company will be responsible for specifically indicating whether the incident meets the definitions of “Rupture” and “Toxic Plume”. For all other events that do not meet any of the definitions in this section, companies are not required to phone the TSB Reporting Hotline but must report the event as soon as possible and no later than twenty-four hours after the event was discovered.

Multiple Incident Types

It is possible that a single occurrence may result in multiple incident types. If multiple incident types occur as a result of a single occurrence, companies are expected to report those incident types under a single incident report.

Examples of situations where this might be the case include but are not limited to:

- a pipeline rupture (occurrence) where there is a release of gas (incident type) and an explosion (incident type);
- an industrial accident (occurrence) that causes a death (incident type), a serious injury (incident type) and a fire (incident type);
- an operational malfunction (occurrence) that causes an overpressure (incident type) and a release of product (incident type); or
- an operational malfunction (occurrence) that causes several concurrent or immediately consecutive overpressures (incident types).

In cases where an incident has occurred, and a second incident occurs during the response to the initial incident (e.g. a fire occurs during the clean-up of a spill), the second incident is considered distinct and should be reported separately.

9.5.5 Notifications and Preliminary Incident Reports

For initial notifications for all incidents and Preliminary Incident Reports, companies must provide, via the OERS, the following information:

- company contact information;
- date and time of occurrence and/or discovery;
- how the incident was discovered (e.g., routine patrol, landowner/public reported);
- type of incident being reported (e.g. death, release of substance, fire/explosion);
- type of substance released and initial release volume estimate, if applicable;
- qualitative details of incident type (e.g., broken bone if serious injury, exposure of a pipeline in a water body if operation beyond design limits, etc.);
- nearest populated center;
- GPS coordinates of the event in decimal degrees;
- facility name/pipeline name;
- narrative that includes a description of the events leading up to the occurrence or discovery and any immediate actions taken to protect the safety of the public, the company’s employees, and/or the environment (e.g., evacuation, containment of product);
- initial narrative information on the component that failed, if applicable; and
- affected lands (e.g., restricted to company owned land, right-of-way, private land, crown land).

9.5.6 Detailed Incident Reports

For Detailed Incident Reports, companies must provide, via the OERS, the following information:

- any relevant updates to the information contained in the notification and/or preliminary incident reports;
- detailed information on the pipeline/facility component that failed (e.g., equipment type, such as gate valve, and the component that failed, such as the valve packing), if applicable;
- operating conditions of the pipeline/facility at the time of incident discovery (e.g. operating pressure, product type, depth of cover, etc.), if applicable;
- maintenance history of failed component (e.g., date of last inspection/maintenance, type of inspection such as visual or non-destructive examination, etc.), if applicable;
- corrective actions completed by the company to prevent reoccurrence of the incident at local level;
- preventative actions completed by the company to prevent the similar incidents across its systems (if applicable, see appendix 1 for additional guidance);
- root cause analysis that includes at least one immediate cause (e.g., equipment/component failure), as well as at least one basic (root) cause (e.g., normal wear and tear); and
- supporting information (e.g., metallurgical reports), if applicable.

9.5.7 Incident Costs

The CER now expects companies to report on costs, as described below, for any incident that meets the following definition under any of the CER's regulations:

- i. An unintended or uncontrolled release of low-vapour pressure (LVP) hydrocarbons in excess of 1.5 m³ that extends beyond a company's property;
- ii. Significant adverse effect on the environment;
- iii. A rupture;
- iv. A toxic plume; and/or
- v. A loss of containment of any fluid from a well.

Companies will be expected to report categorized costs related to the incident as follows:

- Category 1 – Actual costs (to be reported separately) related to:
 - The emergency response, including containment of the incident;
 - The clean-up and remediation of the incident; and
 - The repair or replacement of regulated facilities.
- Category 2 – Actual or estimated value of losses or damages not included in Category 1.

Companies are expected to provide the above costs annually (calendar) beginning the year the incident was reported and ending either when there are no further costs related to the incident or 5 years after the incident was reported (inclusive of the year that it was reported), whichever occurs first.

Reporting of costs will be integrated into the OERS at a later date and at that time OERS will automatically determine when companies are required to report costs. However, until the system changes are made, the CER will contact companies on an as-needed basis and will provide instructions and a standard form to report costs.

9.5.8 *Published Manuals*

All companies operating an oil or a gas pipeline under the jurisdiction of the CER must:

1. Unless the CER otherwise directs, publish the entirety of their emergency procedures manuals on their company's public internet site; provided however, manuals are not required to be published for pipelines described in the exemption clause below. Companies may protect from publication the following information:
 - a. an identifiable individual, including their name, phone number, email address, mailing address and medical condition;
 - b. the vulnerability of particular structures, including methods employed to protect those structures;
 - c. that could prejudice their competitive position or reasonably be expected to result in a material loss or gain to a person affected by publication; and
 - d. about a person, such as a daycare, school or hospital, that was requested by that person to be withheld from publication;
2. Describe information that is protected from publication; and
3. File a written confirmation from the company's accountable officer that the company's emergency procedures manuals have been published and provide a link to the published manuals to the CER and to any interested person that has expressed an interest to the company in the published manuals.

Exemption Clause

Pipelines described in this section are exempt from publication.

High vapour pressure pipelines that are:

1. 168 millimeters or less in outside nominal diameter;
2. 10 kilometres or less in length; and
3. Outside of class 2 or greater locations, as determined by CSA Z662.

Liquid pipelines that are:

1. 168 millimeters or less in outside nominal diameter;
2. 10 kilometres or less in length; and
3. Located more than 500 metres from a navigable water, public drinking water source or a designated environmentally sensitive area.

10.0 FORMS

10.0	FORMS	1
10.1	Initial Emergency Response Form	2
10.1.1	Form A1	2
10.2	Jurisdictional Forms	4
10.2.1	British Columbia Forms	4
10.2.2	Alberta Forms	14
10.3	ICS Forms	23
10.4	ERP Forms	47
10.5	Stakeholder Forms	59
10.6	Media Forms	63
10.7	Administration Forms	67
10.7.1	ERP Manual Receipt	67
10.7.2	Management of Change Request Form	68

10.1 Initial Emergency Response Form

10.1.1 Form A1

This form is used at the outset of an incident to record critical information informing key personnel to ensure a rapid and appropriate response.

Incident Details <i>To be completed by the person involved or notified</i>	
Report taken by	Date / Time
Name of person calling	Caller Telephone
Incident Location (LSD / NTS)	
Event Summary	
Agencies Notified	<input type="checkbox"/> Yes Who? <input type="checkbox"/> No
Event Status	<input type="checkbox"/> Incident contained or controlled <input type="checkbox"/> Intermittent control possible <input type="checkbox"/> Imminent control possible <input type="checkbox"/> Incident is uncontrolled
Site Type	<input type="checkbox"/> Well <input type="checkbox"/> Pipeline <input type="checkbox"/> Tank Farm/Storage <input type="checkbox"/> Battery/Plant/Facility <input type="checkbox"/> Other _____
Incident Type	<input type="checkbox"/> Sour Gas Release <input type="checkbox"/> Sweet Gas Release <input type="checkbox"/> Pipeline Break <input type="checkbox"/> Security (theft, threat, terrorism) <input type="checkbox"/> Loss of Containment <input type="checkbox"/> Fire/Explosion <input type="checkbox"/> Worker Injury/Fatality <input type="checkbox"/> Vehicle/Transportation <input type="checkbox"/> Liquid Spill <input type="checkbox"/> Other _____
Impacts	
Public Health and Safety	<input type="checkbox"/> Could be jeopardized <input type="checkbox"/> Is jeopardized
Public Protection Measures Taken	<input type="checkbox"/> Notification <input type="checkbox"/> Evacuation <input type="checkbox"/> Shelter-in-place <input type="checkbox"/> Roadblocks
Worker Injuries	<input type="checkbox"/> First Aid <input type="checkbox"/> Hospitalized <input type="checkbox"/> Fatality <input type="checkbox"/> Other _____
Distance to nearest surface development	_____ km Distance to nearest urban centre _____ km
Details	
Release Impact	<input type="checkbox"/> On-Lease <input type="checkbox"/> Off-Lease Product _____ Amount _____
Gas Readings	H ₂ S _____ SO ₂ _____ LEL _____ Other _____
Distance to nearest watercourse	_____ km Weather Conditions

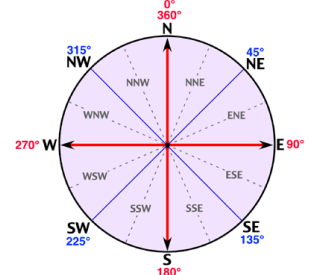

Details		
---------	--	--

Media Involvement?	<input type="checkbox"/> Yes <input type="checkbox"/> No	Regulator Involvement?	<input type="checkbox"/> Yes <input type="checkbox"/> No	Public Affairs/Community Relations Issues?	<input type="checkbox"/> Yes <input type="checkbox"/> No
---------------------------	--	-------------------------------	--	---	--

Details

Notes / Instructions Provided:

--

10.2 Jurisdictional Forms

10.2.1 British Columbia Forms

B.C. Minor Incident Notification Form



Minor Incident Notification Form

This form is to be used for incidents which do not meet BCER Level 1, 2, or 3 Classification. Minor incidents must be reported to the BCER within 24 hours through the Regulator’s Incident Reporting System in CM-IS.

Report Details								
Incident Date / Time	Date			Time				
Incident Classification	Consequence (0-4)			Escalation (0-4)				
EMCR Number					<input type="checkbox"/> Not applicable			
Location								
Permit Holder								
Activity Type	<input type="checkbox"/> Well		<input type="checkbox"/> Facility		<input type="checkbox"/> Pipeline			
	<input type="checkbox"/> Road		<input type="checkbox"/> AACT/ANC		<input type="checkbox"/> Geophysical System			
	<input type="checkbox"/> Short-Term Water Use		<input type="checkbox"/> Changes In and About a Stream					
	<input type="checkbox"/> Other:							
BCER License Information <input type="checkbox"/> Unknown	License Number:							
	Segment Number If Pipeline:							
	LOC ID If Changes In and About a Stream:							
	POD # If Short-Term Water Use:							
Location information At least one type required if license information is unknown	NTS:	Quarter (A-D)	Unit (1-100)	Block (A-L)	Map (82-82, 92-25, 102-103, 114)	Sheet (A-P)	Grid (1-16)	
	DLS:	LSD (1-16)		Section (1-36)		Township (76-88)		Range (13-26)
	UTM:	Zone (7-12)		Easting		Northing		
	GPS:	Latitude			Longitude			
	Location Description:							

Contact Information
If additional information is required, please attach separately

Reporting Contact	Name:		Company:	
	Phone #:		Email:	
Additional Contacts If applicable	Name:	Type:		Company:
	Phone #:		Email:	
	Name:	Type:		Company:
	Phone #:		Email:	
	Name:	Type:		Company:
	Phone #:		Email:	
Contractors / Third Parties Directly Involved If applicable	Name:		Type:	
	Company:		Phone #:	
	Name:		Type:	
	Company:		Phone #:	
Other Agency Notifications				

Incident Description

Incident Type(s) Check all that apply	<input type="checkbox"/> Spill (Liquid or Solid)	<input type="checkbox"/> Equipment/Structural Damage	<input type="checkbox"/> Drilling Kick
	<input type="checkbox"/> Induced Seismicity	<input type="checkbox"/> Security Threat	<input type="checkbox"/> Hydrotechnical
	<input type="checkbox"/> Fire/Explosion	<input type="checkbox"/> Geotechnical	<input type="checkbox"/> Vehicle/Heavy Equipment
	<input type="checkbox"/> Loss of Well Control		<input type="checkbox"/> Environmental
	<input type="checkbox"/> Spill (Gaseous)		
	<input type="checkbox"/> Other:		
Main Industry Activities	<input type="checkbox"/> Construction	<input type="checkbox"/> Well Drilling/Completion	<input type="checkbox"/> Operations/Maintenance
			<input type="checkbox"/> Deactivation/Decommission/Restoration
Secondary Industry Activities Check all that apply	<input type="checkbox"/> Fluid Transfer	<input type="checkbox"/> Pipeline Boring/HDD	<input type="checkbox"/> Third Party – Unintentional Damage
	<input type="checkbox"/> Third Party – Intentional Damage	<input type="checkbox"/> Third Party – Undefined	<input type="checkbox"/> Other:
Incident Description			

Material Information					
Complete if Incident Type – Spill is selected					
Material Spilled Check all that apply	<input type="checkbox"/> Natural Gas <input type="checkbox"/> Oil <input type="checkbox"/> Emulsion <input type="checkbox"/> Produced Water <input type="checkbox"/> Condensate <input type="checkbox"/> Liquefied Natural Gas <input type="checkbox"/> Acid Gas <input type="checkbox"/> LVP Fluids (Pentane Plus) <input type="checkbox"/> HVP Fluids <input type="checkbox"/> Bentonite <input type="checkbox"/> Hydraulic Oil <input type="checkbox"/> Fresh Water <input type="checkbox"/> Hydrogen <input type="checkbox"/> Ammonia <input type="checkbox"/> Diesel/Fuel <input type="checkbox"/> Other (please describe): <input type="checkbox"/> Methanol				
	Does the release contain H2S? <input type="checkbox"/> Yes: ppm <input type="checkbox"/> No <input type="checkbox"/> N/A				
Environment Type Check all that apply	<input type="checkbox"/> Wildland <input type="checkbox"/> Agricultural Land <input type="checkbox"/> Developed Land <input type="checkbox"/> Muskeg/Stagnant Water <input type="checkbox"/> Lake <input type="checkbox"/> Stream				
Land Classification Check all that apply	<input type="checkbox"/> Crown <input type="checkbox"/> Private <input type="checkbox"/> First Nations Reserve <input type="checkbox"/> ALR				
Confined to Lease or Right of Way	<input type="checkbox"/> Yes <input type="checkbox"/> No <input type="checkbox"/> N/A <input type="checkbox"/> Unknown				
Initial Spill Volume	<table border="1" style="width: 100%; border-collapse: collapse;"> <thead> <tr> <th style="width: 60%;">Volume</th> <th style="width: 40%;">Unit</th> </tr> </thead> <tbody> <tr> <td style="height: 20px;"> </td> <td> </td> </tr> </tbody> </table>	Volume	Unit		
Volume	Unit				
Material Information					
Wildlife/Livestock <input type="checkbox"/> Not applicable					
Equipment Loss <input type="checkbox"/> Not applicable	Value: Description:				
Ancillary Damage <input type="checkbox"/> Not applicable					
Regulator Information (BCER Use Only)					
Oversight	<input type="checkbox"/> BCER <input type="checkbox"/> Out of Jurisdiction <input type="checkbox"/> Not Reportable				
BCER Notified Date / Time	<table border="1" style="width: 100%; border-collapse: collapse;"> <thead> <tr> <th style="width: 60%;">Date</th> <th style="width: 40%;">Time</th> </tr> </thead> <tbody> <tr> <td style="height: 20px;"> </td> <td> </td> </tr> </tbody> </table>	Date	Time		
Date	Time				
Staff Dispatched					



Emergency Incident Notification Form

This form is to be used for emergencies which meet BCER Level 1, 2, or 3 Classification. Emergency level incidents must be reported to the Regulator within 1 hour of the incident.

EMCR 24-hour reporting number: 1-800-663-3456

Report Details								
Incident Date / Time	Date			Time				
BCER Notified Date / Time	Date			Time				
Incident Classification	Consequence (0-4)		Escalation (0-4)		Level (1-3)			
EMCR Number						<input type="checkbox"/> Not applicable		
Location								
Permit Holder								
Activity Type	<input type="checkbox"/> Well <input type="checkbox"/> Facility <input type="checkbox"/> Pipeline <input type="checkbox"/> Road <input type="checkbox"/> AACT/ANC <input type="checkbox"/> Geophysical System <input type="checkbox"/> Short-Term Water Use <input type="checkbox"/> Changes In and About a Stream <input type="checkbox"/> Other:							
BCER License Information <input type="checkbox"/> Unknown	License Number:							
	Segment Number If Pipeline:							
	LOC ID If Changes In and About a Stream:							
	POD # If Short-Term Water Use:							
Location information At least one type required if license information is unknown	NTS:	Quarter (A-D)	Unit (1-100)	Block (A-L)	Map (82-82, 92-25, 102-103, 114)	Sheet (A-P)	Grid (1-16)	
	DLS:	LSD (1-16)		Section (1-36)		Township (76-88)		Range (13-26)
	UTM:	Zone (7-12)		Easting		Northing		
	GPS:	Latitude			Longitude			
	Location Description:							

Contact Information			
If additional information is required, please attach separately			
Reporting Contact	Name:		Company:
	Phone #:		Email:
Additional Contacts <small>If applicable</small>	Name:	Type:	Company:
	Phone #:		Email:
	Name:	Type:	Company:
	Phone #:		Email:
	Name:	Type:	Company:
	Phone #:		Email:
Contractors / Third Parties Directly Involved <small>If applicable</small>	Name:		Type:
	Company:		Phone #:
	Name:		Type:
	Company:		Phone #:
Other Agency Notifications			
Incident Description			
Incident Type(s) <small>Check all that apply</small>	<input type="checkbox"/> Spill (Liquid or Solid) <input type="checkbox"/> Equipment/Structural Damage <input type="checkbox"/> Drilling Kick <input type="checkbox"/> Induced Seismicity <input type="checkbox"/> Security Threat <input type="checkbox"/> Hydrotechnical <input type="checkbox"/> Fire/Explosion <input type="checkbox"/> Geotechnical <input type="checkbox"/> Vehicle/Heavy Equipment <input type="checkbox"/> Loss of Well Control <input type="checkbox"/> Environmental <input type="checkbox"/> Spill (Gaseous) <input type="checkbox"/> Other:		
Main Industry Activities	<input type="checkbox"/> Construction <input type="checkbox"/> Well Drilling/Completion <input type="checkbox"/> Operations/Maintenance <input type="checkbox"/> Deactivation/Decommission/Restoration		
Secondary Industry Activities <small>Check all that apply</small>	<input type="checkbox"/> Fluid Transfer <input type="checkbox"/> Pipeline Boring/HDD <input type="checkbox"/> Third Party – Unintentional Damage <input type="checkbox"/> Third Party – Intentional Damage <input type="checkbox"/> Third Party – Undefined <input type="checkbox"/> Other:		
Incident Description			

Material Information	
Complete if Incident Type – Spill is selected	
Material Spilled Check all that apply	<input type="checkbox"/> Natural Gas <input type="checkbox"/> Oil <input type="checkbox"/> Emulsion <input type="checkbox"/> Produced Water <input type="checkbox"/> Condensate <input type="checkbox"/> Liquefied Natural Gas <input type="checkbox"/> Acid Gas <input type="checkbox"/> LVP Fluids (Pentane Plus) <input type="checkbox"/> HVP Fluids <input type="checkbox"/> Bentonite <input type="checkbox"/> Hydraulic Oil <input type="checkbox"/> Diesel/Fuel <input type="checkbox"/> Fresh Water <input type="checkbox"/> Hydrogen <input type="checkbox"/> Ammonia <input type="checkbox"/> Methanol <input type="checkbox"/> Other (please describe):
	Does the release contain H2S? <input type="checkbox"/> Yes: ppm <input type="checkbox"/> No <input type="checkbox"/> N/A
Environment Type Check all that apply	<input type="checkbox"/> Wildland <input type="checkbox"/> Agricultural Land <input type="checkbox"/> Developed Land <input type="checkbox"/> Muskeg/Stagnant Water <input type="checkbox"/> Lake <input type="checkbox"/> Stream
Land Classification Check all that apply	<input type="checkbox"/> Crown <input type="checkbox"/> Private <input type="checkbox"/> First Nations Reserve <input type="checkbox"/> ALR
Confined to Lease or Right of Way	<input type="checkbox"/> Yes <input type="checkbox"/> No <input type="checkbox"/> N/A <input type="checkbox"/> Unknown
Initial Spill Volume	Volume
	Unit
Material Information	
Public Check all that apply	<input type="checkbox"/> Notified <input type="checkbox"/> Sheltered <input type="checkbox"/> Evacuated <input type="checkbox"/> Infrastructure <input type="checkbox"/> Injury <input type="checkbox"/> Fatality
Wildlife/Livestock <input type="checkbox"/> Not applicable	
Equipment Loss <input type="checkbox"/> Not applicable	Value: Description:
Ancillary Damage <input type="checkbox"/> Not applicable	
Regulator Information (BCER Use Only)	
Emergency Officer	
Oversight	<input type="checkbox"/> BCER <input type="checkbox"/> Out of Jurisdiction <input type="checkbox"/> Not Reportable
Intake Situation	<input type="checkbox"/> Evolving <input type="checkbox"/> Stable
Staff Dispatched	
Additional Notes	

B.C. Incident Notification Process (CM-IS)

Effective April 10, 2025, all incident reporting to the BC Energy Regulator must be completed through the Compliance Management Information System (CM-IS). This replaces previous reporting tools including Form D and KERMIT. Permit holders must report incidents directly in CM-IS, using the online data entry forms and integrated communication tools. PDF uploads are no longer accepted for post-incident reviews. Users must have an Online Systems account with appropriate permissions to access CM-IS.

Summary of Reporting Workflow in CM-IS

1. **Log in to CM-IS** via BCER Online Systems.
2. **Select “Incident Reporting”** module.
3. **Enter incident details** directly into the system:
 - Date/time
 - Location
 - Classification (minor, level 1–3)
 - Description and immediate actions taken
4. **Attach supporting documents** (photos, maps, etc.).
5. **Submit report.**
6. **Monitor status** and respond to BCER follow-ups within CM-IS.

CM-IS Section 12 Incident Reporting Process

Reporting Requirements

- **Minor incidents:** Must be reported within **24 hours**.
- **Level 1–3 incidents:** Must be reported **immediately (within 1 hour)**.
- **First Nations notification:** Required as soon as possible for Level 1–3 incidents.

Reporting Method

- All reports are submitted **online via CM-IS**.
- **Direct data entry** replaces PDF uploads (e.g., Form D).
- Communication with BCER is now **integrated into CM-IS**, similar to inspection and non-compliance modules.

User Access

- Users must have a **BCER Online Systems account** with the correct **security role**.
- Company administrators manage user roles.



**TECHNICAL
SAFETY BC**

505 Sixth Street, Suite 200, New Westminster, BC V3L 0E1
Toll free: 1-866-566-7233 Website: www.safetyauthority.ca

Incident Reporting Form

Note: The information on this form is collected to administer the provisions of the BC Safety Standards Act and section 26 of the Freedom of Information and Protection of Privacy Act. If you have questions about the collection, use, or disclosure of this information, contact the Records, Information & Privacy Analyst at 1-866-566-7233.

Instructions for Use

For incidents involving the following technologies:

- | | |
|---|---|
| <input type="checkbox"/> Amusement Rides | <input type="checkbox"/> Passenger Ropeways |
| <input type="checkbox"/> Boilers, Pressure Vessels, Refrigeration | <input type="checkbox"/> Elevating Devices |
| <input type="checkbox"/> Electrical | <input type="checkbox"/> Gas |

Note: For all Amusement Rides and Passenger Ropeways incidents (Level I, II, and III):

1. Call 1-866-566-7233 to report the incident
2. Complete form below:
 1. save the form to your computer
 2. upload the form as an attachment to an email
 3. send to incidents@safetyauthority.ca
3. You may also save a copy for your records.

EMERGENCY RESPONSE

For an incident requiring IMMEDIATE emergency response:
(ambulance, fire, and/or police) CALL 911

LEVEL I & II INCIDENTS

An incident involving serious injuries or damages (Level I & II incidents) must be reported immediately to the Technical Safety BC by:

Telephone: 1-866-566-7233

LEVEL III INCIDENTS

An incident involving minor injuries/damages or no injuries/damages (Level III incidents) must be reported within 24-hours to the Technical Safety BC by:

Email: incidents@safetyauthority.ca

or

Telephone: 1-866-566-7233

Technical Safety BC is working towards going paperless! Participate by signing up for email correspondence.



Incident Reporting Form

Note: The information on this form is collected to administer the provisions of the BC Safety Standards Act and section 26 of the Freedom of Information and Protection of Privacy Act. If you have questions about the collection, use, or disclosure of this information, contact the Records, Information & Privacy Analyst at 1-866-566-7233.

Date Reported: _____

Time Reported: _____

DETAILS

Date Incident Occurred: _____

Time Incident Occurred: _____

Address/Location of Incident:

Type of Premises: _____

If other, please specify: _____

Technology Involved: _____

Incident Description:

Incident Cause:

Description of Injuries

Description of Damages:

Number of People Injured: _____

Equipment/Property Damage: Yes No

Number of Fatalities: _____

Product/Equipment still in service: Yes No

Hospitalization Required: Yes No

Name of Contractor/FSR: _____

Unit Number: _____

Contractor/FSR Phone Number: _____

Permit Number: _____

Notifier's Information:

Name: _____

Organization: _____

Contact Phone Number: _____

By submitting this form, I give consent to Technical Safety BC to verify and disclose the information provided on this form for the purposes consistent with the administration of the Safety Standards Act.

Technical Safety BC is working towards going paperless! Participate by signing up for email correspondence.

Wildfire Emergency Contact Information



For all users: Please refer to the [Wildfire Act](#) and [Wildfire Regulation](#) for statutory responsibilities, obligations and requirements.

INFORMATION ABOUT THE ACTIVITY

Date

Form

Completed:

Worksite Details (manned facilities only e.g. staff on site > 4 hrs/day)			
Project Name		Project Number	
Physical location of activity (helpful if map attached, or attach additional information as necessary)		Type of Activity	
		Specify:	
		Format for Lat & Long: Degrees[space] Minutes[.]Decimal (e.g. 125 15.20)	
		Lat	Long
UDO ID (UDO information to be completed by BCWS)			
Duration of Activities (enter date(s) for appropriate period only)			
Temporary	Start	End	
Intermittent	Dates	Permanent	Start Date
Company Contact Information (INCLUDING sub-contractors - add additional pages if necessary) (For more than one temporary activity taking place, one central contact and number would be sufficient information provided)			
24 hr Company Emergency Line(s) #			
Company Name			
Contact	Phone	E-mail	
Alternate 24 hr Contact Name and Phone(s)			
Company Name			
Contact	Phone	E-mail	
Other Key Emergency Contact(s) # – List contractors and sub-contractors (attach additional pages as necessary)			
Company Name			
Contact	Phone	E-mail	
List of industrial activities (OPTIONAL to complete – as specified in the Wildfire Regulation)			
<input type="checkbox"/> Any high-risk activity as defined in the Wildfire Regulation			
Operating equipment or machinery in relation to forest management during:		Operating equipment or machinery in relation to activities other than forest management during:	
<input type="checkbox"/> road construction, road maintenance and road deactivation <input type="checkbox"/> timber harvesting, including sorting logs <input type="checkbox"/> mechanical modification of forest debris and debris piling <input type="checkbox"/> silviculture treatments <input type="checkbox"/> portable wood chipping, milling, processing or manufacturing <input type="checkbox"/> other (specify) _____		<input type="checkbox"/> debris piling <input type="checkbox"/> road construction, road maintenance or road deactivation <input type="checkbox"/> rock drilling <input type="checkbox"/> mining operations <input type="checkbox"/> railway operations <input type="checkbox"/> utility transmission operations <input type="checkbox"/> portable wood chipping, milling, processing or manufacturing <input type="checkbox"/> other (specify) _____	
Fire Emergency Contact Information			
Forest Fire Reporting: 1-800-663-5555 or * 5555 on most cellular networks			
Fire Centre Contact Information (know which fire centre is local to your activities) See Map .			
Fire Centre	E-mail Form to:	Office Phone	
Coastal	BCWS.COFCDispatch@gov.bc.ca	250-951-4222	
Southeast	BCWS.SEFCDispatch@gov.bc.ca	250-365-4040	
Kamloops	BCWS.KFCDispatch@gov.bc.ca	250-554-7701	
Cariboo	BCWS.CARFCDispatch@gov.bc.ca	250-989-2600	
Prince George	BCWS.PGFCDispatch@gov.bc.ca	250-565-6126	
Northwest	BCWS.NWFCDispatch@gov.bc.ca	250-847-6633	
BC Wildfire Management Branch Website: http://bcwildfire.ca			

Complete this form and submit electronically to the appropriate Fire Centre.

10.2.2 Alberta Forms

Release Report

Initial verbal notification of the release to the AER is required prior to completing this release report

General Information		
AER FIS incident no.:	EDGE reference no.:	
Date AER notified:	Time: <input type="checkbox"/> p.m. <input type="checkbox"/> a.m.	AER contact:
Type of report:	Projected date for final report:	
Incident date:	Time: <input type="checkbox"/> p.m. <input type="checkbox"/> a.m.	Incident location: W
Licensee/Company name:		
Licence no.:	Public lands disposition no.:	
EPEA approval no.:	Scheme/Permit approval no.:	Other AER approval no.:
Form completed by:		Phone number:

Release Volume Details					
If volumes change from what was initially reported, then verbal notification to the AER is required.					
Released Substance*	Volume released	Free Fluids recovered	Shipped to (waste receiver) *	Licence/ approval no.*	Location
	m ³	m ³			W
	m ³	m ³			W
	m ³	m ³			W
Gas	10 ³ m ³				
Release rate:	Duration of release:				
*If the released substance is "Emulsion" the crude oil, produced water, and gas must all be reported separately above.					
*Refer to ST107 for the list of AER approved oilfield waste management (WM) facilities					

Waste Recovery Volume Details				
Waste substance	Volume recovered	Shipped to (waste receiver) *	Licence/ approval no.*	Location
Excavated soil/solids removed	m ³			W
	m ³			W
Contaminated surface water and/or snow removed	m ³			W
	m ³			W
Washwater and/or freshwater used	m ³			W
	m ³			W
Vegetation/crop bagged and/or removed	m ³			W
	m ³			W
*Refer to ST107 for the list of AER approved oilfield waste management (WM) facilities				
Contaminated soils storage: <input type="checkbox"/> Yes <input type="checkbox"/> No <input type="checkbox"/> On site <input type="checkbox"/> Off site – If off site, enter location: W				
On-site waste treatment: <input type="checkbox"/> Yes <input type="checkbox"/> No Waste Treatment Description:				

Release Containment Details		
<input type="checkbox"/> Within well/facility lease boundary – Contained to working surface of lease boundary: <input type="checkbox"/> Yes <input type="checkbox"/> No		
<input type="checkbox"/> Outside well/facility lease boundary		
Release contained by berm: <input type="checkbox"/> Yes <input type="checkbox"/> No	Release contained by liner: <input type="checkbox"/> Yes <input type="checkbox"/> No	Liner type (Directive 055):
Release onto land/soil: <input type="checkbox"/> Yes <input type="checkbox"/> No	Surface soil type:	Subsurface soil type:

Release Site Details		
Land jurisdiction type:	Environment affected:	Area affected: m ²
<input type="checkbox"/> Within public lands disposition boundary	<input type="checkbox"/> Outside public lands disposition boundary – TFA number:	
Distance to closest water body: m	Distance to nearest town: km	Name of nearest town:
Distance to closest water well: m	Distance to nearest permanent dwelling: km	

Release Impacts Details		
Incident/release H ₂ S concentration:	Unit of measurement: <input type="checkbox"/> % <input type="checkbox"/> ppm <input type="checkbox"/> mol/kmol	
Wildlife/livestock affected:	Equipment loss:	
Emergency response plan (ERP) activated: <input type="checkbox"/> Yes <input type="checkbox"/> No		
<input type="checkbox"/> Public affected	<input type="checkbox"/> Public evacuation	<input type="checkbox"/> Number evacuated:
<input type="checkbox"/> Landowner notified*	<input type="checkbox"/> Leaseholder notified*	
<input type="checkbox"/> WH&S notified*	Number of injuries:	Number of fatalities:
*Provide details in Additional Notifications box		

Pipeline Details (fill in for AER licensed-pipeline incident)		
Pipeline is not to be returned to service without permission from the AER. See www.aer.ca for definitions for incident type and cause.		
Incident type:	Incident cause:	
Licence number:	Line number:	Installation cause (if applicable):
Start location: W	End location: W	ABSA registration number (if applicable):
Associated facility location: W	Associated facility licence number:	
<input type="checkbox"/> Test failure <input type="checkbox"/> Retest segment <input type="checkbox"/> Pipeline repair pretested <input type="checkbox"/> Cathodic protection		
Type of external coating:	<input type="checkbox"/> Corrosion mitigation/monitoring program:	
Normal operating pressure: kPa	Maximum operating pressure	kPa
Date line shut in:	Pipeline returned to service: <input type="checkbox"/> No <input type="checkbox"/> Yes	Date:

Clean-up/Remediation Details		
All releases must be remediated or managed in a matter satisfactory to the AER.		
Clean-up status:	Final clean-up/remediation completion date:	
<input type="checkbox"/> In-situ remediation implemented		
Remediation guidelines used (choose all applicable):		
<input type="checkbox"/> Tier 1 <input type="checkbox"/> Tier 2 <input type="checkbox"/> SST <input type="checkbox"/> SCARG <input type="checkbox"/> CCME <input type="checkbox"/> Exposure control		
Method of subsurface delineation:	Confirmatory samples taken: <input type="checkbox"/>	Number of samples:
Remediation certificate applied for: <input type="checkbox"/> Yes <input type="checkbox"/> No		
Environmental contractor:	Phone number:	

Additional Incident Notification Details			
Name of agency/landowner	Person notified/reference no.	Phone number	Date

Incident Details
<p>Submit photos of the incident and clean-up/remediation to the AER. Fill in all text boxes below:</p> <p>Detailed description of circumstances leading up to the release:</p> <p>How release was identified:</p> <p>Steps/procedures taken to minimize, control, or stop release:</p> <p>Steps taken to contain release:</p> <p>If release was on lease steps taken to ensure no migration off lease (including subsurface migration):</p> <p>Description of how release volume(s) was determined and verified (include any calculations used):</p> <p>How the affected area was determined (include any calculations used):</p> <p>Description of environmental impact:</p> <p>Clean-up operation details:</p> <p>Remediation operation details</p> <p>Release cause:</p> <p>Description of root cause:</p> <p>Steps/procedures taken to prevent similar future releases:</p> <p>Additional comments:</p>



ACCIDENT REPORTING FORM

Head Office

ABSA, the pressure equipment safety authority
9410 – 20 Avenue
Edmonton, AB T6N 0A4
Telephone: (780) 437-9100
Fax: (780) 437-7787

Grande Prairie District Office

ABSA, the pressure equipment safety authority
#203, 10109 – 97 Avenue
Grande Prairie, AB T8V 0N5
Telephone: (780) 538-9922
Fax: (780) 538-9400

Fort McMurray District Office

ABSA, the pressure equipment safety authority
103B, 9816 Hardin Street
Fort McMurray, AB T9H 4K3
Telephone: (780) 714-3067
Fax: (780) 714-2380

Calgary District Office

ABSA, the pressure equipment safety authority
Deerfoot Atria South
Suite 380, 6715 - 8 Street NE
Calgary, AB T2E 7H7
Telephone: (403) 291-7070
Fax: (403) 291-4545

Red Deer District Office

ABSA, the pressure equipment safety authority
#304, 4406 Gaetz Avenue
Red Deer, AB T4N 3Z6
Telephone: (403) 341-6677
Fax: (403) 341-3377



Accidents do occur. And when they do, the result is injury, loss of life or damage to property. Keeping accidents to a minimum, especially where boilers, pressure vessels and pressure piping systems are concerned should be everyone's safety objective. But when a boiler, pressure vessel or pressure piping system accident does occur, the owner or the person in charge must report the accident to ABSA, the pressure equipment safety authority.

The first step is to telephone the nearest ABSA office listed on this page. Until an ABSA Safety Codes Officer completes an investigation of the accident scene, or the ABSA Safety Codes Officer advises otherwise, nothing should be touched or removed from the accident site or the surrounding area, unless it is absolutely necessary to prevent further injury, loss of life or property damage.

The ABSA Safety Codes Officer will investigate an accident scene, and file a report. However, Section 35 of the Pressure Equipment Safety Regulation under the Safety Codes Act requires that, as soon as possible, the owner or person in charge must also send a full report in writing to the Administrator. This report is required whenever injury, death or property damage results from an accident involving boilers, pressure vessels, power plants, heating plants, pressure plants or pressure piping systems.

For your convenience, a format for completing this written accident report is provided on the following pages. Your report may be in a different format however, the report must include the required information.

To report an accident, or to obtain further information about ABSA, the pressure equipment safety authority, please contact one of the offices listed.



ACCIDENT REPORT

To be completed by the owner or person in charge whenever injury, loss of life or property damage results from an accident involving a boiler, pressure vessel or pressure piping system. (Please Print).

Contact Information

Name of owner/person in charge: _____

Title: _____

Mailing address: _____

Telephone number: _____

Email address: _____

Chief Inspector/Management Representative (if applicable)

Name: _____

Mailing address: _____

Telephone Number: _____

Email address: _____

Site Contact: _____

Name: _____

Phone Number: _____

Synopsis of Accident

Name and address of plant: _____

Type of Plant: _____

Specific location of accident: _____

Date of accident: _____

Time: _____

Name of Victims
(if possible, please describe injuries or cause of death.)

Damage to Property
(list all pressure equipment involved including title description of items, "A" Number, model number, CRN, service, description, severity of damage, etc.)

Description of Accident
Brief plant description, chronological sequence of events; clear understanding of what happened; root cause; preventative measures taken. (Sequence of events before, during and after the event.)

Supporting Material
Please list all appropriate drawings, sketches, photographs, signed statements, Engineer Reports, Root Cause Analysis, etc., that you have included with this report.

Notification

The following relevant authorities
have been notified

Probable Cause of Accident

List major contributing causes in
order of their importance.

**Actions and Preventative
Measure Taken by Owner**

Steps to prevent occurrences of
similar accidents.

Accident Notification Details

Reported to ABSA by: _____

Name of ABSA Contact: _____

Date and Time of Notification: _____

When completed, this form should be sent to:

Administrator & Chief Inspector
ABSA, the pressure equipment safety authority
9410 – 20th Avenue
Edmonton, AB T6N 0A4



ELECTRICAL INCIDENT REPORT FORM

LOCAL FILE NUMBER _____
DATE _____

DETAILS OF ACCIDENT	Human Fatality	<input type="checkbox"/> Yes <input type="checkbox"/> No	Human Injury	<input type="checkbox"/> Yes <input type="checkbox"/> No	Animal Fatality	<input type="checkbox"/> Yes <input type="checkbox"/> No	
	Date of Accident			Time of Day			
	Exact Location of Accident						
			LSD	Section	Township	Range	West of
	Name of Person Injured or Involved			Occupation		Age	Phone No.
	Address					Postal Code	
	Description of Injury (if any)						
	Employer					Phone No.	
	Address					Postal Code	
	Description of Accident (state facts only)						

ELECTRICAL EQUIPMENT INVOLVED	Description of Electrical Equipment Involved in Accident (including power lines)	
	-	
	Voltage (to gnd. or 0-0)	
Owner of Equipment		Operator of Equipment (if different from owner)

OTHER EQUIPMENT INVOLVED	Description of Other Equipment Involved in Accident		
	-		
	License No. of Equipment (if applicable)	Make and/or Type of Equipment (if applicable)	
	Owner of Equipment		Phone No.
	Address		Postal Code
	Operator of Equipment		Phone No.
Address		Postal Code	

Reported By	Firm Name	Location	Phone No.
-------------	-----------	----------	-----------

SUBMIT COPIES TO:
 Technical Administrator for the Electrical Discipline
 16th Floor, 10155 – 102 Street, Edmonton, Alberta T5J 4L4
 Email: safety.services@gov.ab.ca Fax: 780-427-8686 Phone: 1-866-421-6929

10.3 ICS Forms

ICS 201 - Incident Briefing

DETAILS	Incident:	
	Date:	
	Time (0-2400 hrs):	Time Zone:
	Prepared by (Name and Position):	Signature:
MAP SKETCH		
SITUATION SUMMARY AND SAFETY BRIEFING		

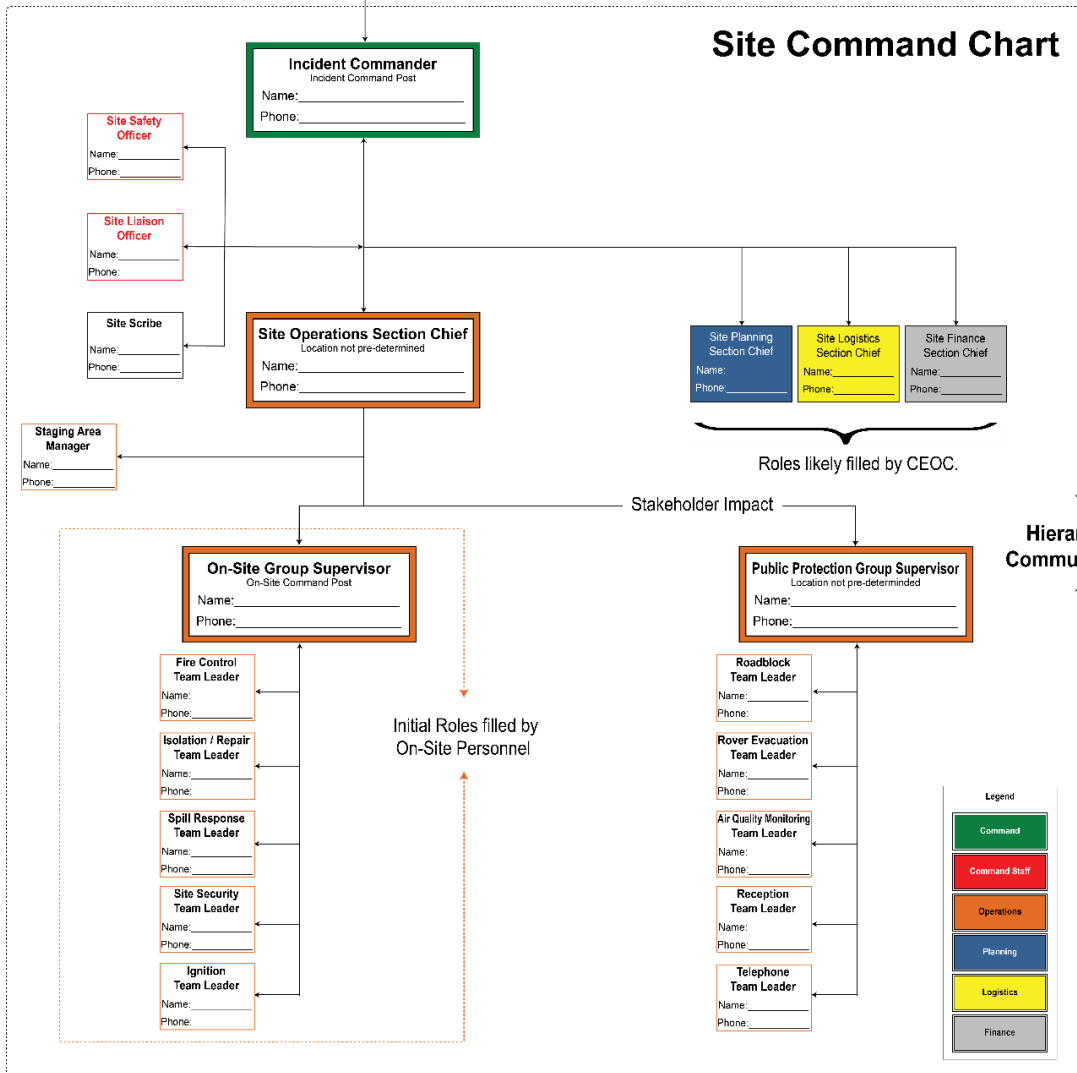
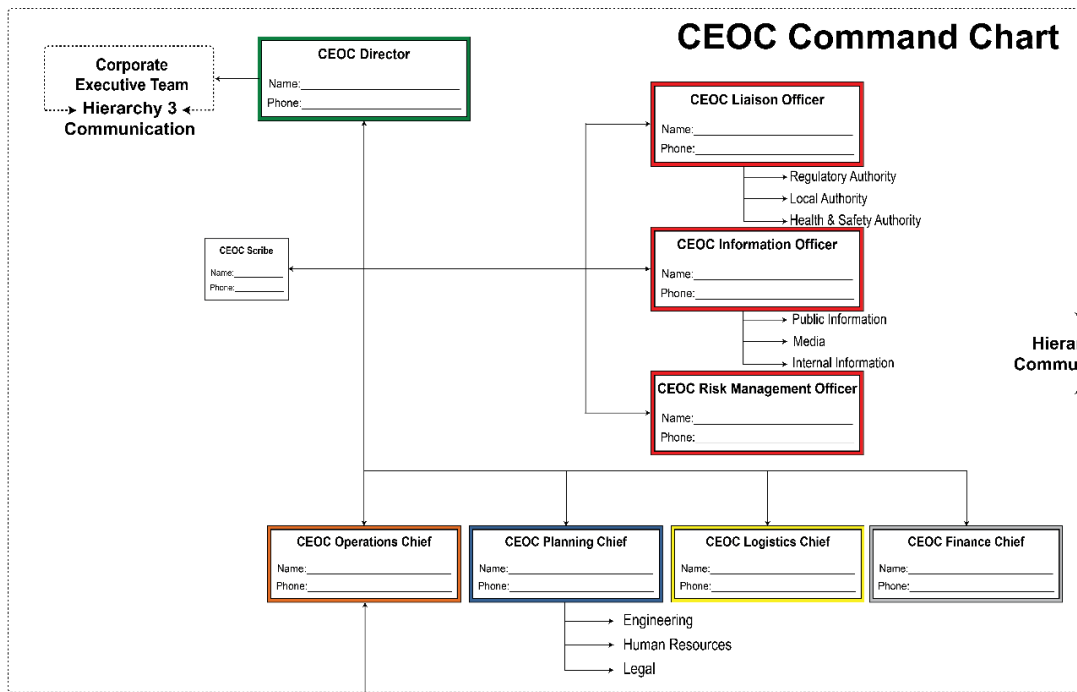

ICS 202 - Incident Objectives

DETAILS	Incident:	
	Date:	
	Time (0-2400 hrs):	Time Zone:
	Operational Period (Date/Time)	Date From: _____ Date To: _____ Time From: _____ Time To: _____
	Prepared by (Site Planning Section Chief or CEOC Planning Chief):	Signature: _____
	Approved by (Incident Commander):	Signature: _____
GENERAL CONTROL OBJECTIVES FOR THE INCIDENT	(Include alternatives)	
WEATHER FORECAST		
GENERAL SAFETY MESSAGE		
ATTACHMENTS	<input type="checkbox"/> ICS 203 - Organization List <input type="checkbox"/> Medical Plan (ICS 206) <input type="checkbox"/> _____ <input type="checkbox"/> ICS 204 - Assignment List <input type="checkbox"/> ERP Map <input type="checkbox"/> _____ <input type="checkbox"/> _____	
		PAGE 1 OF 1

ICS 203 - Organization Assignment List

DETAILS	Incident:				
	Date:				
	Time (0-2400 hrs):		Time Zone:		
	Operational Period (Date/Time)		Date From: _____	Date To: _____	
			Time From: _____	Time To: _____	
Prepared by (Site-Planning Section Chief or CEOC Section Chief):			Signature:		
INCIDENT COMMAND STAFF	Incident Commander		OPERATIONS SECTION	Site Operations Section Chief	
	Deputy IC			a. Staging Area Manager	
	Site Safety Officer			b. Public Protection Group Supervisor	
	Site Liaison Officer			Roadblock Team Leader	
	Unified Commander(s)			Rover Evacuation Team Leader	
				Air Monitoring Team Leader	
				Reception Team Leader	
				Telephone Team Leader	
AGENCY/ ORGANIZATION REPRESENTATIVES	Agency/Organization	Representative			
SITE/CEOC PLANNING SECTION	Site Planning Section Chief				
	CEOC Planning Section Chief				
	Engineering				
	Human Resources				
	Legal				
SITE/CEOC LOGISTICS SECTION	Site Logistics Section Chief				
	CEOC Logistics Chief				
	a. Additional Support				
	b. Additional Services				
CEOC/SITE FINANCE /ADMIN SECTION					

ICS 204 - Assignment List

DETAILS	Incident:							
	Operational Period (Date/Time)		Date From: _____		Date To: _____			
			Time From: _____		Time To: _____			
	Prepared by (Site Operations Section Chief):				Signature:		Date/Time	
Approved by (Planning Section Chief):				Signature:		Date/Time		
OPERATING PERSONNEL	Site Operations Section Chief: _____ Staging Area Manager: _____ Public Protection Group Supervisor: _____ On-Site Group Supervisor: _____							
RESOURCES ASSIGNED TO THIS PERIOD	Resource Identifier	Leader	No. of Persons	Contact Cell #, radio freq. etc.	Reporting Location, Special Equipment and Supplies, Remarks			
WORK ASSIGNMENTS								
SPECIAL INSTRUCTION								
COMMUNICATION	Function:	Frequencies:	System:	Chan:	Function:	Frequencies:	System:	Chan:
	Command				Logistics			
	Tactical (Field Operations)				Air to Ground			
								PAGE 1 OF 1

ICS 206 - Medical Plan

DETAILS	Incident:									
	Date:									
	Time (0-2400 hrs):								Time Zone:	
	Operational Period (Date/Time)		Date From: _____			Date To: _____				
			Time From: _____			Time To: _____				
	Prepared by (Site Safety Officer):					Signature: _____		Date/Time		
Approved by (Incident Commander):					Signature: _____		Date/Time			
INCIDENT MEDICAL AID STATION	Medical Aid Stations		Location			Contact (number or frequency)		Paramedics		
								Yes	No	
								<input type="checkbox"/>	<input type="checkbox"/>	
								<input type="checkbox"/>	<input type="checkbox"/>	
								<input type="checkbox"/>	<input type="checkbox"/>	
								<input type="checkbox"/>	<input type="checkbox"/>	
TRANSPORTATION	Ambulance Service		Location			Contact (number or frequency)		Level of Serv.		
								ALS	BLS	
								<input type="checkbox"/>	<input type="checkbox"/>	
								<input type="checkbox"/>	<input type="checkbox"/>	
								<input type="checkbox"/>	<input type="checkbox"/>	
								<input type="checkbox"/>	<input type="checkbox"/>	
HOSPITALS	Hospital Name	Address (lat/long if helipad)	Travel Time		Contact (number or frequency)	Helipad		Burn Centre		
			Air	Ground		Yes	No	Yes	No	
						<input type="checkbox"/>	<input type="checkbox"/>	<input type="checkbox"/>	<input type="checkbox"/>	
						<input type="checkbox"/>	<input type="checkbox"/>	<input type="checkbox"/>	<input type="checkbox"/>	
						<input type="checkbox"/>	<input type="checkbox"/>	<input type="checkbox"/>	<input type="checkbox"/>	
						<input type="checkbox"/>	<input type="checkbox"/>	<input type="checkbox"/>	<input type="checkbox"/>	
SPECIAL MEDICAL EMERGENCY PROCEDURES										

ICS 207 - Incident Organization Chart

DETAILS	Incident:		
	Date:		
	Time (0-2400 hrs):		Time Zone:
	Operational Period (Date/Time)	Date From: _____ Time From: _____	Date To: _____ Time To: _____
	Prepared by (Name & Position):		Signature

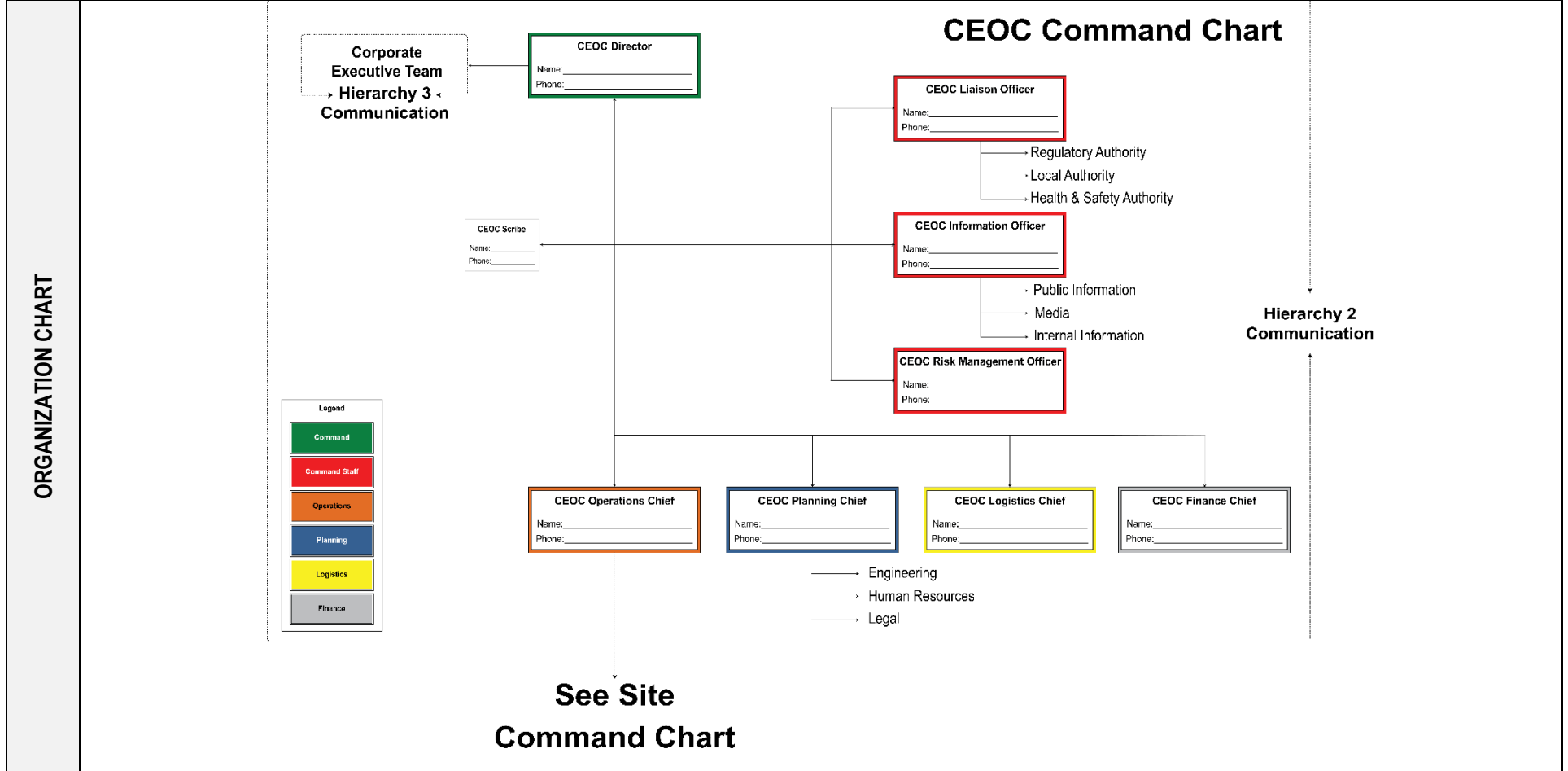

See CEOC Command Chart

Site Command Chart

ORGANIZATION CHART

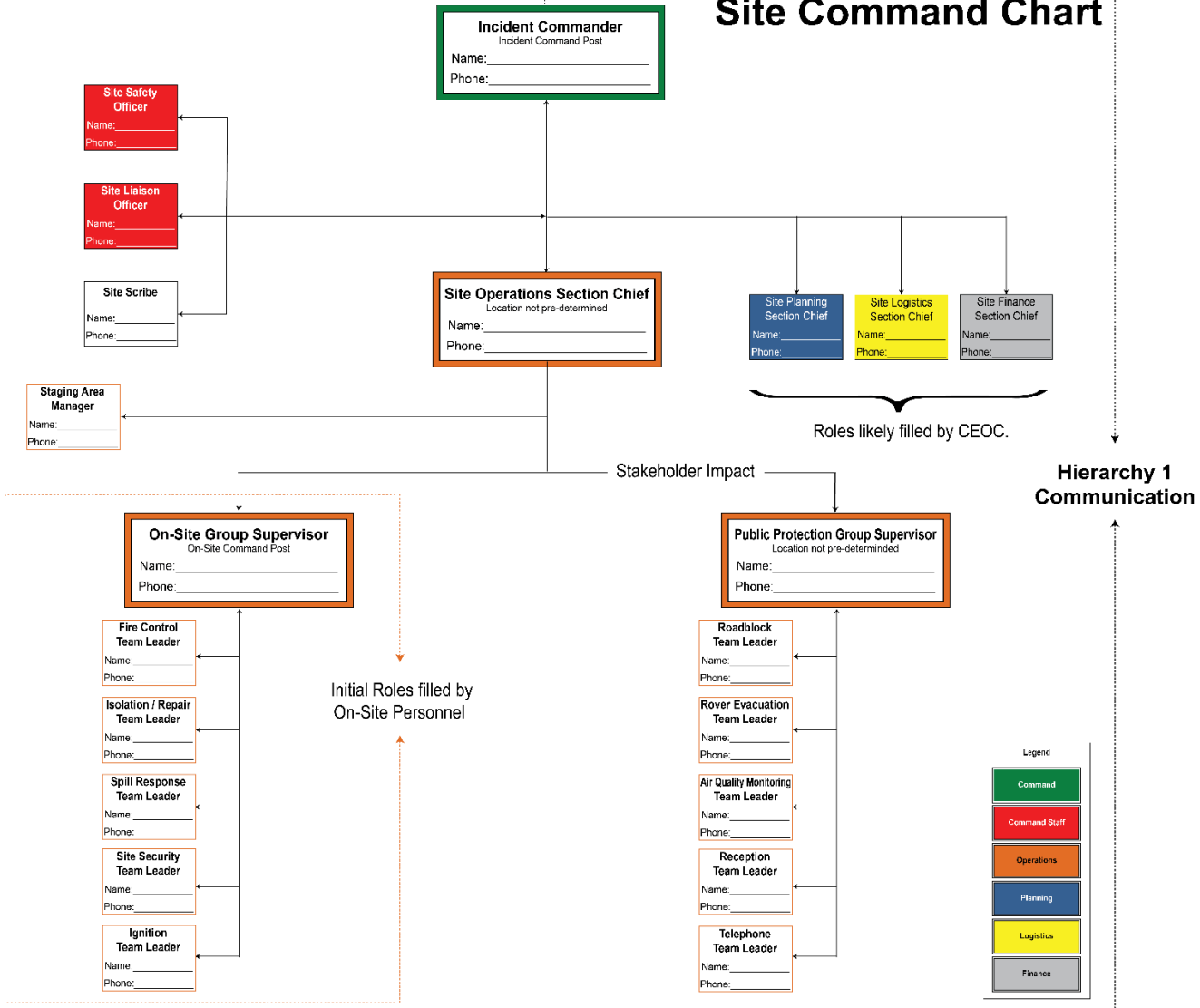

DETAILS	Incident:	
	Date:	
	Time (0-2400 hrs):	Time Zone:
	Operational Period (Date/Time)	Date From: _____ Date To: _____ Time From: _____ Time To: _____
	Prepared by (Site Safety Officer):	Signature:
SAFETY MESSAGE/EXPANDED SAFETY MESSAGE, SAFETY PLAN, SITE SAFETY PLAN		
SAFETY PLAN	Site Safety Plan Required? Yes <input type="checkbox"/> No <input type="checkbox"/> Approved Site Safety Plan(s) located at: _____	
		PAGE 1 OF 1

ICS 209 - Incident Status Summary

DETAILS	*Incident Name:		Incident No:		
	*Report Version Check one box on left): <input type="checkbox"/> Initial Rpt# <input type="checkbox"/> Update (if used) <input type="checkbox"/> Final	*Incident Commander(s) & Agency or Organization	Incident Management Organization	*Incident Start Date/Time Date: Time:	
	Current Incident Size or Area Involved (Use unit label – e.g. 'sq km', 'city block')	% Contained <hr/> Completed	*Incident Definition	Incident Complexity Level	*For Time Period From Date/Time: To Date/Time:
APPROVAL & ROUTING INFORMATION	*Prepared by:		ICS Position:	Signature:	*Date/Time
	Approved by:		ICS Position:	Signature:	*Date/Time
	*Date/Time Submitted:				
	*Primary Location, Organization, or Agency Sent To:				
INCIDENT LOCATION INFORMATION	*Province/Territory		*County, Regional/Rural Municipality, Regional/Municipal District		*City
	Unit or Other		*Incident Jurisdiction		Incident Location Ownership (if different than jurisdiction)
	Longitude	Latitude	Datum		Legal Description (twp, range, section)
	*Short location or area description (list all affected areas or a reference point)				*UTM Coordinates
	Note any electronic geospatial data included or attached (indicate data format, content, and collection time information and labels)				
INCIDENT SUMMARY	*Significant events for the time period reported (summarize significant progress made, evacuations, incident growth, etc.)				
	Primary materials or hazards involved (hazardous chemicals, fuel types, infectious agents, radiation, etc.)				
	Damage Assessment Information (summarize damage and/or restriction of use or availability to residential or commercial property, natural resources, critical infrastructure and key resources, etc.)	Structural Summary	# Threatened (72 hrs)	# Damaged	# Destroyed
		Single Residences			
		Non-residential Commercial Property			
Other Minor Structures					
Other					
*required when applicable					

DETAILS	*Incident Name:			Incident No:				
	*Public Status Summary		# This Reporting Period	Total # To Date	*Responder Status Summary		# This Reporting Period	Total # To Date
ADDITIONAL INCIDENT DECISION SUPPORT INFORMATION	Indicate number of Stakeholders (public) below			Indicate number of responders below				
	Fatalities				Fatalities			
	With Injuries/Illness				With Injuries/Illness			
	Trapped/In Need of Rescue				Trapped/In Need of Rescue			
	Missing (note if estimated)				Missing (note if estimated)			
	Evacuated (note if estimated)				Evacuated (note if estimated)			
	Sheltering in Place (note if estimated)				Sheltering in Place (note if estimated)			
	In Reception Centres (note if estimated)				In Reception Centres (note if estimated)			
	Total # Stakeholders (Public) Affected				Total Responders Affected			
	Life, Safety, and Health Status/Threat Remarks				Life, Safety, and Health Threat Mgmt			Check if active
					No likely threat			<input type="checkbox"/>
					Potential Future Threat			<input type="checkbox"/>
					Mass notifications in progress			<input type="checkbox"/>
					Mass notifications completed			<input type="checkbox"/>
					No evacuation(s) imminent			<input type="checkbox"/>
					Planning for evacuation			<input type="checkbox"/>
					Planning for shelter-in-place			<input type="checkbox"/>
	Weather Concerns (synopsis of current and predicted weather, discuss related factors that may cause concern)				Evacuation(s) in progress			<input type="checkbox"/>
					Shelter-in-Place in Progress			<input type="checkbox"/>
					Area restriction in effect			<input type="checkbox"/>
					<input type="checkbox"/>			
					<input type="checkbox"/>			
					<input type="checkbox"/>			
					<input type="checkbox"/>			
					<input type="checkbox"/>			
					<input type="checkbox"/>			
					<input type="checkbox"/>			
Project Incident Activity, Potential, Movement, Escalation, or Spread and influencing factors during the next operational period and in 12-, 24-, 48-, and 72-hour timeframes								
12 hours								
24-hours								
48 hours								
72 hours								
Anticipated after 72 hours								
Objectives (define planned end-state for incident)								

*required when applicable

DETAILS	*Incident Name:	Incident No:
	<p>CURRENT INCIDENT THREAT SUMMARY AND RISK INFORMATION IN 12-, 24-, 48-, AND 72-HOUR TIMEFRAMES AND BEYOND Summarize primary incident threats to life, property, communities and community stability, residences, health care facilities, other critical infrastructure and key resources, commercial facilities, natural and environmental resources, cultural resources, and continuity of operations and/or business. Identify corresponding incident-related potential economic or cascading impacts.</p>	
ADDITIONAL INCIDENT DECISION SUPPORT INFORMATION (continued)	12 hours	
	24-hours	
	48 hours	
	72 hours	
	Anticipated after 72 hours	
	<p>Critical Resource Needs in 12-, 24-, 48-, and 72-hour timeframes and beyond to meet critical incident objectives. List resource category, kind, and/or type, and amount needed, in priority order:</p>	
	12 hours	
	24-hours	
	48 hours	
	72 hours	
	Anticipated after 72 hours	
	<p>Strategic discussion: explain in relation to overall strategy, constraints, and current available information to: 1) critical resource needs identified above, 2) the Incident Action Plan and management objectives, 3) anticipated results. Explain major problems and concerns such as operational challenges, incident management problems, and social, political, economic, or environmental concerns or impacts.</p>	
	Planned Actions for Next Operational Period	
	Projected final incident size/area (Use Unit Label – e.g., “sq km”)	
	Anticipated Incident Management Completion Date	
Projected Significant Resource Demobilization Start Date		
Estimated Incident Costs to Date		
Projected Final Incident Cost Estimate		
Remarks (or continuation of any blocks above – list block number in notation)		

*required when applicable

ICS 211 - Check-In List

DETAILS	Incident Name:	Incident Number (if assigned):	Check-In Location										Start Date/Time						
			<input type="checkbox"/> OSCP <input type="checkbox"/> ICP <input type="checkbox"/> Staging Area <input type="checkbox"/> CEOC <input type="checkbox"/> Helibase <input type="checkbox"/> Other _____										Date: Time:						
Prepared by (Name & Position):											Signature								
CHECK-IN INFORMATION (use reverse of form for remarks or comments)	List Personnel (overhead) by Agency & Name – OR List Resources by the Following Format							LDW	Order Request Number	Date/Time Check-In	Leader's Name	Total Number of Personnel	Contact Information	Home Unit/ Base	Departure Point	Method of Travel	Incident Assignment	Other Qualifications	Sent to Resource Unit
	P/T	AGENCY	CAT.	KIND	TYPE	ST/TF	Resource Name or ID #												
	Remarks or Comments																		

ICS 214 - Activity Log

DETAILS	Incident:		
	Date:		
	Time (0-2400 hrs):		Time Zone:
	Operational Period (Date/Time)	Date From: _____ Time From: _____	Date To: _____ Time To: _____
	Prepared by:	ICS Position:	Signature:
PERSONNEL ASSIGNED	Name	ICS Position	Command Centre (OSCP, ICP, CEOC)
ACTIVITY LOG	Time	Major Events	

ICS 215 - Operational Planning Worksheet

DETAILS	Incident:																					
	Date:																					
	Time (0-2400 hrs):												Time Zone:									
	Operational Period (Date/Time)						Date From: _____						Date To: _____									
							Time From: _____						Time To: _____									
Prepared by (Site Operations Section Chief):												Signature										
OPERATIONAL PLANNING	Branch	Division, Group, or Other	Work Assignment & Special Instructions	Resources														Overhead Position(s)	Special Equipment & Supplies	Reporting Location	Requested Arrival Time	
				Req.																		
				Have																		
				Need																		
				Req.																		
				Have																		
				Need																		
				Req.																		
				Have																		
				Need																		
				Req.																		
				Have																		
				Need																		
Total Resources Required																						
Total Resources – Have on Hand																						
Total Resources Need to Order																						
Page:																						

ICS 215a - Incident Action Safety Plan Analysis

DETAILS	Incident:		
	Date:		
	Time (0-2400 hrs):		Time Zone:
	Operational Period (Date/Time)	Date From: _____ Time From: _____	Date To: _____ Time To: _____
	Prepared by (Site Safety Officer):	Name: _____	Signature: _____
	Prepared by (Site Operations Section Chief):	Name: _____	Signature: _____
INCIDENT ACTION SAFETY PLAN	Incident Area	Hazards/Risks	Mitigations

ICS 221 - Demobilization Checkout

DETAILS	Incident Name/Number:		Date/Time:			Demob Number:	
	Prepared by (Site Planning Section Chief or CEOC Planning Chief):					Signature	
	Approved by (Incident Commander):					Signature	
	Unit/Personnel Released:						
	Transportation Type/Number:						
	Actual Release Date/Time:					Manifest Completed <input type="checkbox"/> Yes <input type="checkbox"/> No	
	Destination:		Notify	ICP <input type="checkbox"/>	Agency <input type="checkbox"/>	Region <input type="checkbox"/>	Area <input type="checkbox"/>
		Name					
		Date					
UNIT/PERSONNEL	You and your resources have been released subject to Sign-Off from the following: Site Planning Section Chief or CEOC Planning Chief - Check the appropriate box						
	LOGISTICS SECTION			COMMENTS			
	<input type="checkbox"/> Site Logistics Section Chief						
	<input type="checkbox"/> CEOC Logistics Section Chief						
	<input type="checkbox"/> a. Additional Support						
	<input type="checkbox"/>						
	<input type="checkbox"/> b. Additional Services						
	<input type="checkbox"/>						
	PLANNING SECTION						
	<input type="checkbox"/> Site Planning Section Chief						
	<input type="checkbox"/> CEOC Planning Section Chief						
	<input type="checkbox"/> Engineering						
	<input type="checkbox"/> Human Resources						
	<input type="checkbox"/> Legal						
	OPERATIONS SECTION						
<input type="checkbox"/> Site Operations Section Chief							
<input type="checkbox"/> Staging Area Manager							
<input type="checkbox"/> Public Protection Group Supervisor							
<input type="checkbox"/> Roadblock Team Leader							
<input type="checkbox"/> Rover Evacuation Team Leader							
						Page 1 of 2	

DETAILS	Incident Name/Number:	Date/Time:	Demob Number:
	Prepared by (Site Planning Section Chief or CEOC Planning Chief):		Signature
	Approved by (Incident Commander):		Signature
UNIT/PERSONNEL Continued	<input type="checkbox"/> Air Monitoring Team Leader		
	<input type="checkbox"/> Reception Team Leader		
	<input type="checkbox"/> Telephone Team Leader		
	<input type="checkbox"/> On-Site Group Supervisor		
	<input type="checkbox"/> Fire Control Team Leader		
	<input type="checkbox"/> Isolation Repair Team Leader		
	<input type="checkbox"/> Spill Response Team Leader		
	<input type="checkbox"/> Site Security Team Leader		
	<input type="checkbox"/> Ignition Team Leader		
	<input type="checkbox"/> a. Additional Support		
	<input type="checkbox"/>		
	<input type="checkbox"/> b. Additional Services		
	<input type="checkbox"/>		
	FINANCE/ADMIN SECTION		
	<input type="checkbox"/> Site Finance Section Chief		
	<input type="checkbox"/> CEOC Finance Chief		
	CORPORATE EMERGENCY OPERATIONS CENTRE (CEOC)		
	<input type="checkbox"/> CEOC Director		
	<input type="checkbox"/> CEOC Operations Chief		
	<input type="checkbox"/> CEOC Liaison Officer		
<input type="checkbox"/> CEOC Risk Management Officer			
REMARKS:			

ICS 230 – Daily Meeting Schedule

DETAILS	Incident: _____				
	Operational Period (Date/Time)		Date From: _____	Date To: _____	
			Time From: _____	Time To: _____	
	Prepared by (Planning Chief): _____		Signature: _____		Date/Time _____
MEETING SCHEDULE	Date/Time	Meeting Name	Purpose	Attendees	Location

ICS 234 – Work Analysis Matrix

DETAILS	Incident:		
	Operational Period (Date/Time)	Date From: _____	Date To: _____
		Time From: _____	Time To: _____
	Prepared by (Operations Chief):	Signature:	Date/Time
	Operation's Objectives DESIRED OUTCOME	Strategies HOW	Tactics/Work Assignments WHO, WHAT, WHERE, WHEN

10.4 ERP Forms

Environmental Monitoring Record

DETAILS	Incident:									
	Date:									
	Time (0-2400 hrs):							Time Zone:		
	Completed by:							Response Team Position:		
ENVIRONMENTAL MONITORING RECORD	Time	Location of Sample:	LEL (%)	O₂ (%)	H₂S (ppm)	SO₂ (ppm)	Other	Temp. (C/F°)	Wind Conditions	
									From	Speed (km/h/mph)
Page:										

Notification Record

DETAILS	Incident:			
	Date:			
	Time (0-2400 hrs):			Time Zone:
	Completed by:			
INCIDENT COMMANDER		Who was notified?	Date/Time	Who did notification?
	Supervisor:			
	Ambulance:			
	Police:			
	Fire Department:			
	Forestry Service:			
	Local Authority:			
	Prime Contractor:			
	Area Stakeholder:			
	Other:			
CEOC OPERATIONS CHIEF		Who was notified?	Date/Time	Who did notification?
	Executive Team:			
	President:			
	Disaster Services:			
	Regulatory Authority:			
	Workplace Health and Safety Authority:			
	Health Authority:			
	Hospital/Health Care Facility:			
	Environmental Agency:			
	Other:			

Roadblock Checkpoint Record

DETAILS	Incident:						
	Date:						
	Time (0-2400 hrs):					Time Zone:	
	Completed by:					Response Team Position:	
ROADBLOCK CHECKPOINT RECORD	Vehicle Type	Licence Plate Number & Province/State	Name of Driver (if available)	Number of People in Vehicle	Time Entering EPZ	Time Exiting EPZ	Comments (Record all vehicles turned away)
Page:							

Note: The licensee has the responsibility to protect the public but without the assistance of the police cannot legally prevent the public from entering the secured area. If someone insists on going through the roadblock, ask him or her for emergency contact numbers, this may encourage the driver to stop.

Spill/Release Written Report Form

DETAILS	Incident:							
	Date of Notification:							
	Time of Notification (0-2400 hrs):						Time Zone:	
	Completed by:				Phone Number:			
DISCOVERY	Name of person who discovered release:				Phone number:			
	Date of Release (Estimate if necessary):				Time of Release (Estimate if necessary):			
	Date Release Discovered:				Time Release Discovered:			
LOCATION	Nearest Town/Road Intersection:							
	Directions:							
	Facility Name (any signs indicating well name, rig number, etc.):							
	LSD, if known:							
	Additional Location Information:							
WEATHER CONDITIONS	Temperature °C							
	Wind speed and direction:							
	Precipitation:							
SPILL/RELEASE	Name of product/substance:							
	Volume (m ³)/Quantity (bbl) Spilled/Released:				Volume/Quantity Recovered:			
	<input type="checkbox"/> Sweet gas	<input type="checkbox"/> LVP	<input type="checkbox"/> HVP	<input type="checkbox"/> Toxic substance	<input type="checkbox"/> Sour gas	<input type="checkbox"/> Produced water	<input type="checkbox"/> Oil	<input type="checkbox"/> Other
	Was there a fire? <input type="checkbox"/> Yes <input type="checkbox"/> No				Was there an explosion? <input type="checkbox"/> Yes <input type="checkbox"/> No			

RELEASE INFORMATION		Yes	No	Details
	Is the health or safety of any individuals (residences, communities, etc.) in imminent danger?	<input type="checkbox"/>	<input type="checkbox"/>	
	Are any specially designated environmental areas (wetland, preserves, etc.) in imminent danger?	<input type="checkbox"/>	<input type="checkbox"/>	
	Was any waterway affected?	<input type="checkbox"/>	<input type="checkbox"/>	If yes, provide name of waterway:
	Was release contained? If no, describe dimensions of release (length, width depth). If yes, describe containment (within firewall, booms, etc.).	<input type="checkbox"/>	<input type="checkbox"/>	
Description of release and impacts, including wells and/or facilities involved, and the source of release (stuffing box rubber on well head burned up, internal corrosion on flow line, etc.):				

RESPONSE ACTIONS	Resource	Contractor/Equipment	Estimated Cost
	List contractors summoned to assist in containment:		\$
			\$
			\$
	List contractors summoned to assist in clean-up:		\$
			\$
			\$
	List special clean-up equipment used:		\$
			\$
			\$
Describe remedial action taken and current status:			



LANDING ZONE INFORMATION CARD



STEP 1

Advise your dispatch centre which channel you will be using to communicate with STARS.

STEP 2

Select an area for the landing zone that is downwind from the incident site (unless hazardous materials or gases are present).



STEP 3

Select an area for the landing zone that is a minimum of 36 metres (or 120 feet, or 36 paces) from the incident site.



36 METRES
(120 FEET OR 36 PACES)



STEP 4

Select a flat, level surface for the landing zone; preferably pavement or concrete, if available.



STEP 5

Ensure the landing zone area is clear of wires, poles, trees and debris.



STEP 6

Mark out a 36 metre by 36 metre (120 feet x 120 feet, or 36 paces x 36 paces) square, and mark the corners with LED beacons, heavy pylons or any other bright conspicuous objects easily seen from the air.

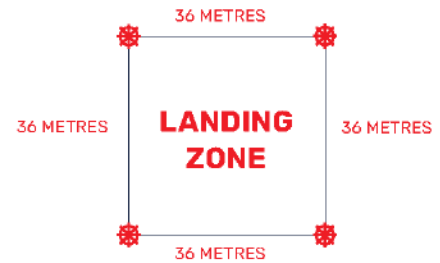

STEP 7

Brief STARS crew via radio or cell phone and stand at the middle of the upwind side of the landing zone with the wind at your back.

Monitor radio frequency to communicate with the STARS team.

As the helicopter approaches, go down on one knee and DO NOT MOVE from your position.

Do not approach the helicopter at any time unless escorted by the STARS crew.

LANDING ZONE HAND SIGNALS



ALL CLEAR TO LAND ALL CLEAR TO DEPART ABORT LANDING



LANDING ZONE BRIEFING FOR STARS CREW



STEP 1

Identify yourself and confirm the Landing Zone Officer is present, with the landing zone secure.

STEP 2

Communicate the location of the landing zone using N/E/S/W to reference the incident scene or other landmarks.

STEP 3

Identify the type of surface for the landing zone (field, road, other).

STEP 4

State what marking the corners of the landing zone: LED beacons, heavy pylons or any other bright conspicuous objects easily seen from the air.

STEP 5

Communicate the wind direction and approximate speed.

STEP 6

Identify the hazards in the area of the landing zone such as wires, poles, trees, or hazardous materials using N/E/S/W in reference to the landing zone.

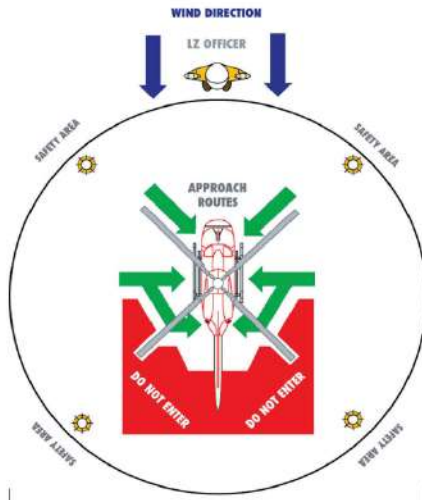

STARS LANDING ZONE

SPECIAL CONSIDERATION

Remove any loose debris and indicate if there is snow or dust in the landing zone. If dusty, water down the landing zone, if possible, prior to the helicopter's arrival. As marshaller, maintain your position at the middle of the upwind side of the landing zone, go down on one knee and **DO NOT MOVE** from your position as the helicopter lands.

If you have any questions or comments regarding this landing zone information card or would like to watch our landing zone video, please visit stars.ca



EMERGENCY LINK CENTRE 1-888-888-4567

This number can also be used to provide a landing briefing to the STARS crew if radio communications are not available.

SITE #

LOCATION

Telephone Checklist for Threatening Calls

DETAILS	Date:							
	Time (0-2400 hrs):			Time Zone:				
	Completed by:							
CALL DETAILS	When a threat is received: <ul style="list-style-type: none"> • Have someone listen in on the call and have call traced, if possible. • Listen. • Be calm and courteous. • Do not interrupt the caller. • Obtain as much information as you can. 							
	Questions to ask for bomb threats: <ul style="list-style-type: none"> • When is the bomb going to explode? • Where is it right now? • Why did you place the bomb? • What does it look like? • What will cause it to explode? • What is your name and address? 							
	Exact wording of the threat:							
	BACKGROUND SOUNDS							
	<input type="checkbox"/>	Street Noises	<input type="checkbox"/>	PA System	<input type="checkbox"/>	Motor	<input type="checkbox"/>	Animal noises
	<input type="checkbox"/>	Local	<input type="checkbox"/>	Crockery	<input type="checkbox"/>	Music	<input type="checkbox"/>	Office machinery
<input type="checkbox"/>	Clear	<input type="checkbox"/>	Long distance	<input type="checkbox"/>	Voices	<input type="checkbox"/>	House noises	
<input type="checkbox"/>	Factory	<input type="checkbox"/>	Static	<input type="checkbox"/>	Booth	<input type="checkbox"/>	Other	
THREATENING LANGUAGE								
<input type="checkbox"/>	Well spoken (educated)	<input type="checkbox"/>	Foul	<input type="checkbox"/>	Irrational			
<input type="checkbox"/>	Message being read by threat maker	<input type="checkbox"/>	Taped	<input type="checkbox"/>	Incoherent			
CALLER DETAILS	Distinguishing accent:							
	Age:		Sex:					
	Length of call:		Number called:					
	CALLER'S VOICE							
	<input type="checkbox"/>	Calm	<input type="checkbox"/>	Angry	<input type="checkbox"/>	Excited	<input type="checkbox"/>	Slow
	<input type="checkbox"/>	Rapid	<input type="checkbox"/>	Soft	<input type="checkbox"/>	Loud	<input type="checkbox"/>	Laughter
	<input type="checkbox"/>	Crying	<input type="checkbox"/>	Normal	<input type="checkbox"/>	Distinct	<input type="checkbox"/>	Slurred
	<input type="checkbox"/>	Nasal	<input type="checkbox"/>	Stutter	<input type="checkbox"/>	Lisp	<input type="checkbox"/>	Raspy
<input type="checkbox"/>	Deep	<input type="checkbox"/>	Ragged	<input type="checkbox"/>	Clearing throat	<input type="checkbox"/>	Deep breathing	
<input type="checkbox"/>	Cracking	<input type="checkbox"/>	Disguised	<input type="checkbox"/>	Accent	<input type="checkbox"/>	Familiar	
If familiar, who did it sound like:								
NOTES								
				Page:				

Report call immediately to your supervisor, corporate security, or administrative services.

Size-Up the Situation Form

Size Up the Situation Form	
<i>To be completed by the person(s) involved or notified</i>	
Report Taken By:	Date: Time:
Name of Person Calling:	Caller Contact:
Incident Location:	
Incident Details:	
Agencies Notified	<input type="checkbox"/> Yes Which Agency? <input type="checkbox"/> No
Incident Status	<input type="checkbox"/> Incident contained or controlled <input type="checkbox"/> Intermittent control possible <input type="checkbox"/> Imminent control possible <input type="checkbox"/> Incident is uncontrolled
Site Type	<input type="checkbox"/> Well <input type="checkbox"/> Pipeline <input type="checkbox"/> Tank Farm Storage <input type="checkbox"/> Plant Battery Facility Other (please specify):
Incident Type	<input type="checkbox"/> Gas Release <input type="checkbox"/> Sour Gas? <input type="checkbox"/> Sweet Gas? <input type="checkbox"/> Pipeline Failure <input type="checkbox"/> Security (theft, vandal, threat) <input type="checkbox"/> Loss of Containment <input type="checkbox"/> Fire <input type="checkbox"/> Injury <input type="checkbox"/> Vehicle <input type="checkbox"/> Spill Other (please specify):
Impacts	
Distance to nearest surface development _____ km	Distance to nearest urban centre _____ km
Public Health and Safety	<input type="checkbox"/> Jeopardized <input type="checkbox"/> Could be Jeopardized
Public Protection Measures Implemented	<input type="checkbox"/> Notification <input type="checkbox"/> Evacuation <input type="checkbox"/> Shelter-In-Place <input type="checkbox"/> Roadblocks

Worker Injuries	<input type="checkbox"/> First Aid <input type="checkbox"/> Medical Aid <input type="checkbox"/> Hospital <input type="checkbox"/> Fatality			
	Other (please specify):			
Details:				
Release Impact	<input type="checkbox"/> On-Lease	<input type="checkbox"/> Off-Lease	Product	Amount
Gas Readings	H ₂ S	SO ₂	LEL	Other
Distance to Nearest Watercourse		km	Weather Conditions	
Details:				
Media Involvement	Regulator Involvement		Public Affairs/Community Relations Issues	
Yes <input type="checkbox"/> No <input type="checkbox"/>	Yes <input type="checkbox"/> No <input type="checkbox"/>		Yes <input type="checkbox"/> No <input type="checkbox"/>	
Problems:				

Incident Priorities Chart

INCIDENT PRIORITIES					BLACK GOLD Emergency Planners Inc.
PEAR	PROBLEM	OBJECTIVE	STRATEGY	TACTICS	TIME FRAME
<i>People Environment Assets Reputation</i>	<i>A problem is a threat or a potential threat to any, or all priorities</i>	<i>An objective is the simplest solution to the problem facing your priority(s)</i>	<i>Strategies are the way, or the ways that you achieve your objective</i>	<i>Tactics are the resources (people/equipment) required to do the job</i>	<i>Estimated time to complete this objective</i>
Operational Period:				To:	From:

10.5 Stakeholder Forms

Stakeholder Contact Record

DETAILS	Incident:						
	Date:						
	Time (0-2400 hrs):				Time Zone:		
	Completed by:				Response Team Position:		
STAKEHOLDER CONTACT RECORD	Resident ID	Name	Shelter in Place or Evacuate	Number of People		Assistance or Transportation Required	Comments
				Inside	Outside		
Page:							



Notice of Evacuation
for

(Location)

_____(Company) has experienced a _____ at the above mentioned facility, which has created an emergency in the area.
As a safety precaution we have implemented our Emergency Response Plan. Please proceed immediately out of the area by the most direct route.
To ensure your safety please check-in with our Reception Centre Representative at the _____(Reception Centre) of _____(City), _____(Phone).

If you have access to a telephone please call our Evacuation Team Leader immediately at _____(Phone).

_____(Company)Representatives have secured the hazardous area with road blocks. If you have any questions or concerns contact our head office at _____.

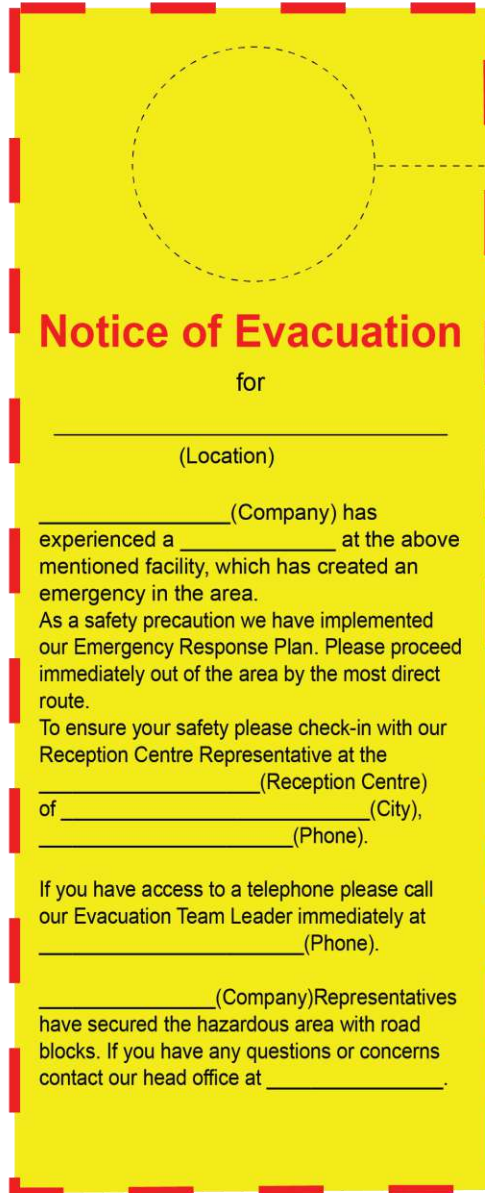

Notice of Evacuation
for

(Location)

_____(Company) has experienced a _____ at the above mentioned facility, which has created an emergency in the area.
As a safety precaution we have implemented our Emergency Response Plan. Please proceed immediately out of the area by the most direct route.
To ensure your safety please check-in with our Reception Centre Representative at the _____(Reception Centre) of _____(City), _____(Phone).

If you have access to a telephone please call our Evacuation Team Leader immediately at _____(Phone).

_____(Company)Representatives have secured the hazardous area with road blocks. If you have any questions or concerns contact our head office at _____.



Notice of Evacuation
for

(Location)

_____(Company) has experienced a _____ at the above mentioned facility, which has created an emergency in the area.
As a safety precaution we have implemented our Emergency Response Plan. Please proceed immediately out of the area by the most direct route.
To ensure your safety please check-in with our Reception Centre Representative at the _____(Reception Centre) of _____(City), _____(Phone).

If you have access to a telephone please call our Evacuation Team Leader immediately at _____(Phone).

_____(Company)Representatives have secured the hazardous area with road blocks. If you have any questions or concerns contact our head office at _____.

Reception Centre Registration Form (to be filled out by evacuees)

DETAILS	Incident:					
	Date:					
	Time (0-2400 hrs):				Time Zone:	
	Completed by:					
EVACUEE INFORMATION	Last Name		First Name		Middle Initial:	
	Sex:	Age:	Address:			
	City:		Province:		Phone Number:	
EVACUATED FAMILY MEMBERS	First Name	Middle Initial	Last Name	Relationship to above	Gender	Age
ALTERNATE CONTACT INFO						
SPECIAL MEDICAL NEEDS						
ADDITIONAL INFO						
CHECK IN/OUT	Arrival Time:				Departure Time:	

Evacuee Expense Claim Form

DETAILS	Incident:		
	Date:		
EVACUEE INFORMATION	Last Name	First Name	Middle Initial:
	Address:		Phone Number:
	City:	Province:	Postal Code:
	Location of Residence, Business, etc.		
EXPENSES	Accommodation:	\$	Details:
	Meals	\$	Details:
	Other Reasonable Expenses:	\$	Details:
	Other:	\$	Details:
	Other:	\$	Details:
	Other:	\$	Details:
	Total:		
Evacuee Signature:			
ADMINISTRATION	Company Contact:		Company Phone Number:
	Approved by:		

10.6 Media Forms

Preliminary Media Statement

Date:(YY/MM/DD)	Responder Name:
Responder Position:	Responder Phone No.:

This is the information I can give you so far:

At _____ (time - 0-2400 hrs) _____ on (date),
a(n) _____ (fire, explosion, gas release, spill) occurred at the Company's _____ (location
name) site, located _____ (distance) kilometres _____ (east/west/north/south) of
_____ (nearest town or city).

Presently, _____ (number of personnel) workers are being treated for injuries. The names and condition of the
injured cannot be released until their families have been contacted.

The _____ (well site, plant, pipeline, office, drilling location) has been _____ (shutdown,
isolated, or is still flowing) .

Company staff have been activated and are directing emergency response procedures to protect the public, our workers and the
environment.

The cause of the _____ (fire, explosion, gas release, spill) is not yet known and no estimate of damage is
available. As information becomes available, news releases will be issued from the CEOC Information Officer.

Any further inquiries should be directed to the CEOC Information Officer, who will issue a press release at a later time.

Contact:
_____ (Name): _____ (Phone)

Note: Only the CEOC Information Officer designated by the CEOC Director is to provide any specific information to the public or
the media.

Media Contact Log

Date:	Responder Name:
Responder Position:	Responders Phone No.:

If you feel you are not the appropriate person to be answering the media agencies questions, use the following series of statements.

"NorthRiver Midstream Inc. has a CEOC Information Officer to answer all media questions."

"May I request the following information to expedite your request?" (complete the form below).

"Thank you. NorthRiver appreciates your cooperation and I will pass on this information to the appropriate person."

Time	Call To	Call From	Media Outlet	Reporter/Contact Name	Telephone Numbers		Remarks/Information Required
					Work	Fax	

Page:

Document all key events, conversations, and meetings on this form. Where lengthy notes are necessary, use additional copies or the back of the page.

Government Agency Contact Log

Date:	Responder Name:
Responder Position:	Responders Phone No.:

If you feel you are not the appropriate person to be answering the government agency representative's questions, use the following series of statements.

"NorthRiver Midstream Inc. has a CEOC Liaison Officer to answer your media questions."

"May I request the following information to expedite your request?" (complete the form below).

"Thank you. NorthRiver appreciates your cooperation and I will pass on this information to the appropriate person."

Time	Call To	Call From	Agency	Contact Name	Telephone Numbers		Remarks/Information Required
					Work	Fax	

Page:

Document all key events, conversations, and meetings on this form. Where lengthy notes are necessary, use additional copies or the back of the page.

10.7 Administration Forms

10.7.1 ERP Manual Receipt

**EMERGENCY RESPONSE PLAN
MANUAL RECEIPT FORM**

Upon receipt of this Emergency Response Plan Manual, this Receipt Form must be completed and returned to the Emergency Response Specialist in the Corporate Office. The Manual holder is responsible for ensuring that the Manual is kept current by inserting the latest revisions as they are issued.

Recipient Name (please print): _____

Position: _____

Field Area Name, if applicable: _____

Date: _____

Signed: _____

ERP Number (from Distribution List): _____

Name of ERP: _____

Return signed copy to:

Attention:

10.7.2 Management of Change Request Form

MANAGEMENT OF CHANGE REQUEST FORM

[Redacted]
[Redacted]
[Redacted]
[Redacted]
[Redacted]

Section Number: _____

Page Number: _____

Copies of revised pages attached: yes no

Description of Amendment:

Requested By: _____

Address: _____

Request Acknowledgement: _____

Request Numbered and Logged: _____

Correspondence Required: _____

Approved By: _____

Approval Date: _____

Revision Date: _____

Issue Date: _____

11.0 APPENDIX

11.1 Risk Assessment

Risk Assessment Purpose

Risk assessment is a method for analyzing the probability and impact of failure on personnel, the public, the facility, the environment, and/or NorthRiver's reputation. Utilizing the Hazard, Risk and Vulnerability Assessment Matrix during the response to an emergency will help to ensure the incident is managed within NorthRiver risk tolerances.

The nature of the hazard(s) will influence the responses that are implemented by the Site Operations Section Chief and the Incident Commander. NorthRiver risk management during response to any incident is based on the following:

- Activities that present an extreme risk to workers, responders, and public must be limited to only situations where there is a potential to save endangered lives. Life Safety is the number one priority in every incident; this includes the safety of responders.
- Where there is no possibility to save lives, personnel should not attempt extreme risk operations.
- Activities to protect the environment or property are recognized as inherent risks to the safety of response personnel and actions should be taken to reduce or avoid these risks.

The Incident Commander is responsible for the overall coordination and direction of all activities and has the primary responsibility to evaluate the risk to on-site personnel with respect to the purpose and potential results of their actions in each situation. In situations where the risk to personnel is excessive, activities should be limited to defensive and protective operations.

The Site Operations Section Chief has the primary responsibility to evaluate the risk to on-site personnel with respect to the purpose and potential results of their actions in each situation. In situations where the risk to personnel is excessive, activities should be limited to defensive and protective operations.

Determining Risk

There are four steps in assessing the risk of an activity or process (see Hazard, Risk and Vulnerability Assessment Matrix):

1. Identify the risk or concern: Describe the risk or concern.
2. Assess the impact: The potential consequence of an incident is defined in terms of impact to people, the environment, operational assets, and the company's reputation.
3. Assess the Probability: The probability of occurrence is estimated in a range from Remote to Frequent.
4. Plot risk level and take action: Risk is categorized in terms of:
 - Critical - the activities must stop until risk controls have been implemented to reduce the risk to a lower level.
 - High - extensive risk controls must be immediately implemented.
 - Moderate - risk controls are required.
 - Low - some risk controls are justified.

Hazard Identification

NorthRiver Emergency Response Plans are compliant 'all hazards' ERPs covering production operations. Although written and employing an 'all hazards' approach, the focus of these plans are upstream petroleum production operations.

Under Canadian Standards Association (CSA) Z1600-08, organizations are required to identify and monitor hazards that can have an impact on their operations or areas of responsibility. Organizations are mandated to consider the impact of natural, technological hazards and human-caused.

Hazards and risks for NorthRiver were identified and vulnerabilities were assessed by NorthRiver Emergency Response Planning section personnel using the Hazard, Risk and Vulnerability Assessment Matrix. As per the Risk Assessment process, staff evaluated information to facilitate the assignment of both probability and impact scores to the three categories of hazards. The combined scores were then plotted on the Risk Matrix so that the Risk Potential/Level could be determined, and appropriate ERP procedures developed where necessary.

Hazard, Risk and Vulnerability Analysis Tool

Step 1 – Assess the Impact

Level	People	Environment	Assets	Reputation
4 Critical	<ul style="list-style-type: none"> Fatality Long-term health impact Permanent disability Life altering injury or illness Evacuation of a facility and community Action from / activist involving weapons 	<ul style="list-style-type: none"> Severe long-term environmental damage Wide-spread impacts to sensitive environments, wildlife and/or major bodies of water Significant off lease/site groundwater impacts 	<ul style="list-style-type: none"> One-month facility/equipment outage Production, equipment, property, motor vehicle loss and or damage greater than \$10 million Terrorist attack/attempt 	<ul style="list-style-type: none"> Action resulting in regulatory and/or legal prosecution or suspension of operations Prolonged national/international media attention Sustained widespread stakeholder public protest
3 High	<ul style="list-style-type: none"> Short term health impact Lost time injury or illness Evacuation of facility and immediate area Violent action from landowner/ activist 	<ul style="list-style-type: none"> Severe short-term environmental damage Localized on lease groundwater impacts Significant off lease/site surface impacts 	<ul style="list-style-type: none"> One-week facility/equipment outage Production, equipment, property, motor vehicle loss and or damage greater than \$1 million Substantial loss from theft/vandalism 	<ul style="list-style-type: none"> Regulatory and/or legal action resulting in fines or punitive action Prolonged national/regional media attention Prolonged local/regional stakeholder public protest
2 Moderate	<ul style="list-style-type: none"> Medical aid injury or illness Restricted work/modified duties Evacuation of job site Specific threat from landowner/ activist 	<ul style="list-style-type: none"> Moderate environmental damage No groundwater impacts Localised off lease/site surface impacts Immediate clean-up 	<ul style="list-style-type: none"> Short term (less than one week) facility/equipment outage Production, equipment, property, motor vehicle loss and or damage greater than \$100,000 Major property crime 	<ul style="list-style-type: none"> Regulatory and/or legal action resulting in administrative response Brief local/regional media attention Brief local public protest
1 Low	<ul style="list-style-type: none"> First aid injury or illness Implied threat from landowner/ activist 	<ul style="list-style-type: none"> Minor environmental damage Localized on lease/site surface impacts 	<ul style="list-style-type: none"> Negligible production loss Protection, equipment, property, motor vehicle loss and/or damage less than \$100,000 Minor property crime 	<ul style="list-style-type: none"> No regulatory action anticipated Brief or no media attention Brief or no public attention

Step 2 – Determine the Probability

Level	Description	Likelihood
4 Frequent	Event is expected to occur in most circumstances.	One or more occurrences per year.
3 Likely	Event will probably occur at home time based on current practices.	One occurrence every 1-5 years.
2 Unlikely	Event should occur at some time based on current practices	One occurrence ever 5-20 years
1 Remote	Event could occur at some time based on current practices	One in the life of the facility

Step 3 – Determine the Risk Level

Impact	4 Critical				
	3 High				
	2 Moderate				
	1 Low				
		1 – Remote	2 – Unlikely	3 – Likely	4 – Frequent

Probability
Impact x Probability = Risk Level

Step 4 – Risk Level

Critical – STOP activities. Work cannot proceed until risk is reduced to a lower level.

High – Extensive risk controls/mitigation measures must be implemented, and possible corporate approval is required to allow work to proceed. Efforts to reduce risk to a MEDIUM or LOW level should be undertaken.

Moderate- Risk controls/mitigation measures must be implemented to allow work to proceed. Efforts to reduce risk to a LOW level should be undertaken.

Low – Some risk controls/mitigation measures may be justified. Represents an acceptable level of risk.

Step 5 – Take Action

Ensure all Risks are understood, controlled, and communicated prior to starting work.

11.2 Setting up a Roadblock on a Roadway

Primary Roadblock – Single Lane Roads

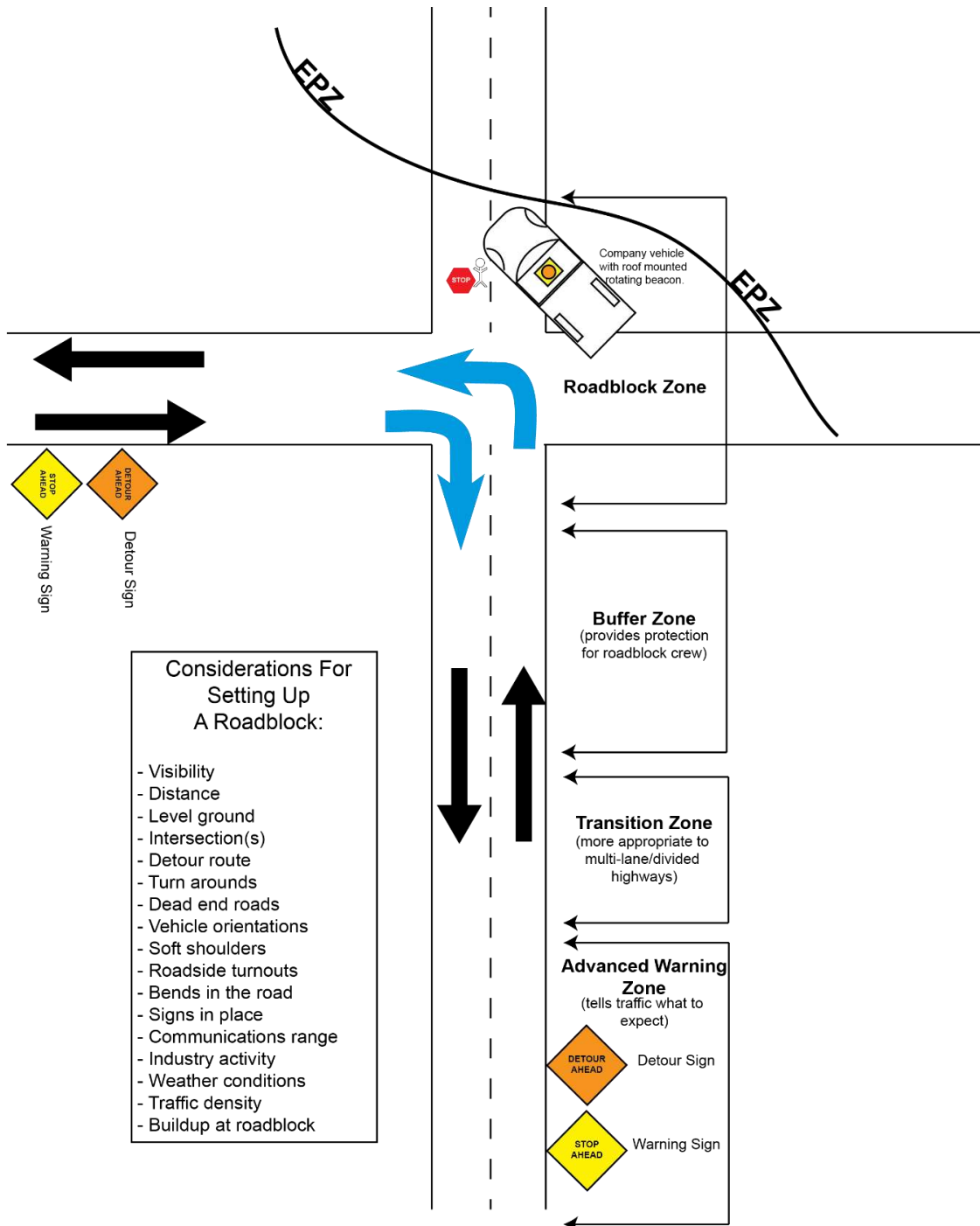

Secondary roadblock locations might be established to facilitate re-routing traffic around the hazard area. All diverted traffic would be re-routed to the secondary roadblock locations.

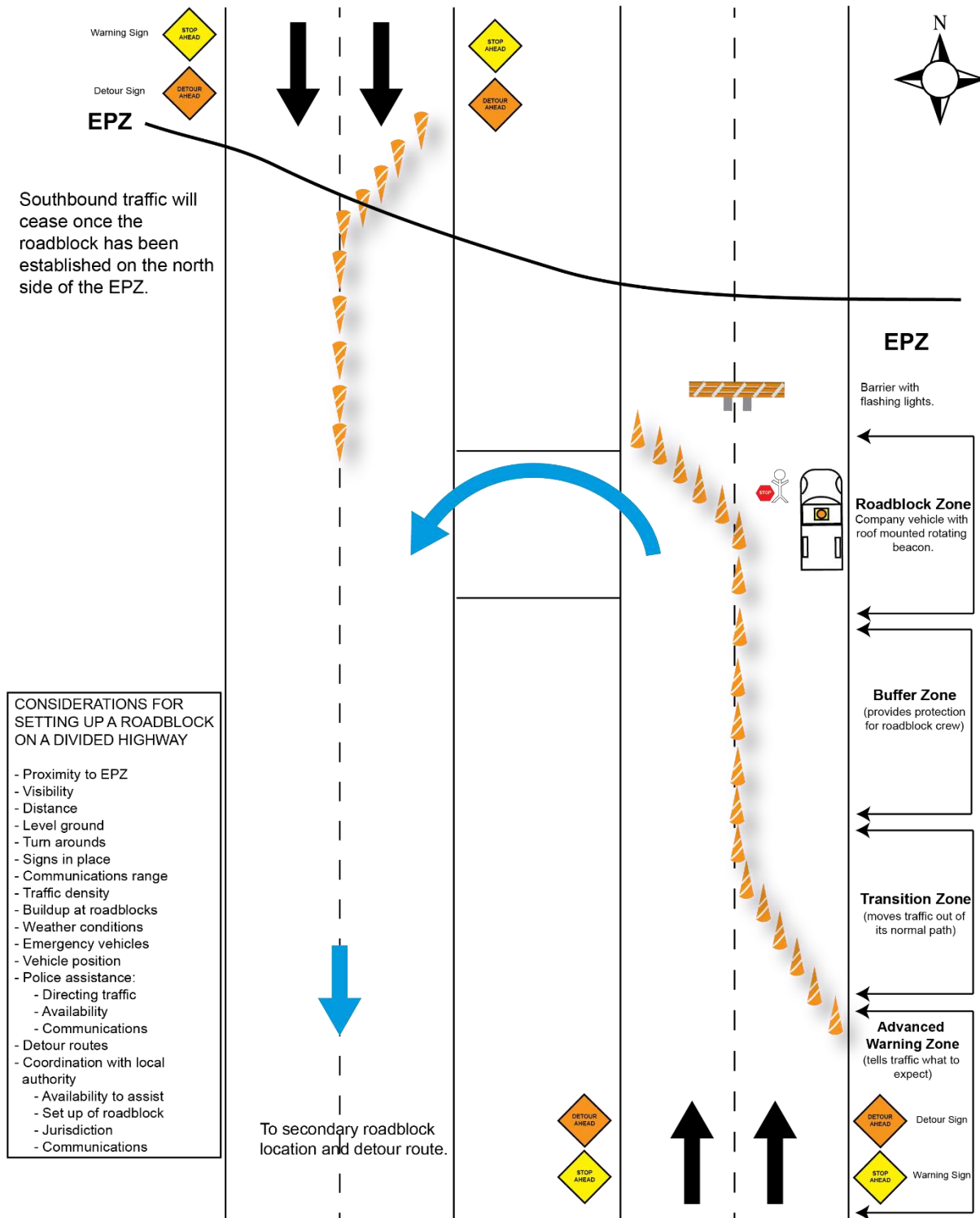

Primary Roadblock – Multi-Lane/Divided Highway

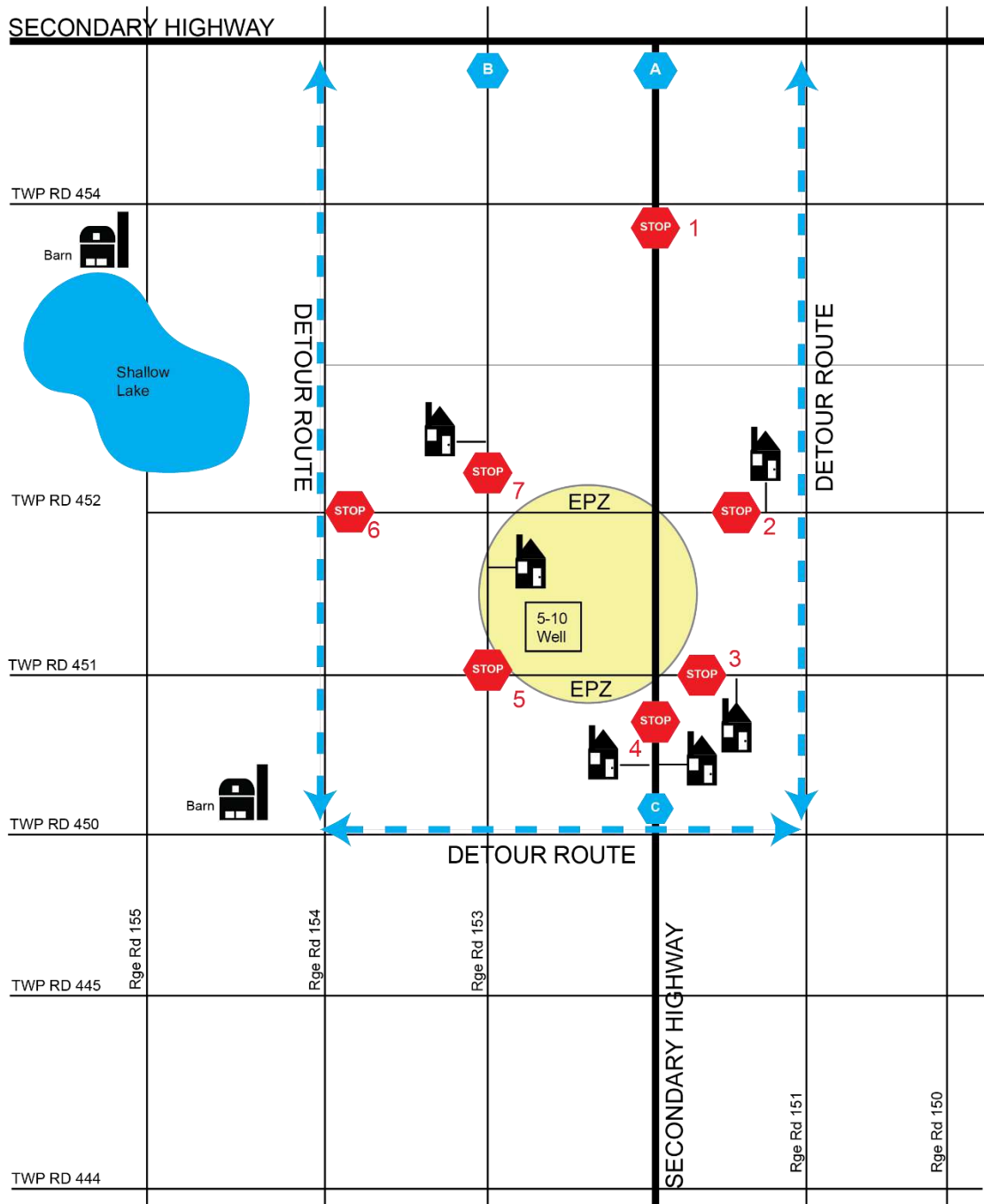

In this scenario, the roadblock will be set up prior to the arrival and assistance from either the Provincial Authority responsible for primary highways or the Police. Secondary roadblock locations must be established to facilitate re-routing around the EPZ area. All diverted traffic would be re-routed to the secondary roadblock locations.

Secondary Roadblock – Placement Schematic



-  Primary roadblock to cordon off the EPZ.
-  Secondary roadblock to reroute traffic on busy roads.
-  Detour route.



11.3 CANUTEC 2024 – Hazard Reference Tables

CANUTEC 2024 – Hazard Reference Table					
Hazardous Product	General Description	Health Effects	Downwind Evacuation	Fire	EPZ Public Safety (immediate precautionary measures)
Methane	<ul style="list-style-type: none"> Often referred to as “sweet gas”. Flammable. Lighter than air. At room temperature and standard pressure, methane is a colorless, odorless gas. It is the simplest alkane and the main component of natural gas. 	<ul style="list-style-type: none"> Vapors may cause dizziness or asphyxiation without warning. Some may be irritating if inhaled at high concentrations. Contact with gas or liquefied gas may cause burns, severe injury and/or frostbite. Fire may produce irritating and/or toxic gases. 	<p>Large Spill Consider initial downwind evacuation for at least 800 metres (1/2 mile)</p>	<p>If tank, rail car or tank truck is involved in a fire, isolate for 1600 metres (1 mile) in all directions; also, consider initial evacuation for 1600 metres (1 mile) in all directions.</p>	<p>100 m (330 ft)</p>
Methane, compressed					
Natural gas, compressed					
Propane	<ul style="list-style-type: none"> Extremely Flammable – will be easily ignited by heat, sparks or flames. Colourless Denser than air. When odourized has a sulphur type odour. Non-odourized has a slight hydrocarbon odour. A by-product of natural processing and petroleum refining, it is commonly used as a fuel for engines, oxy-gas torches, portable stoves, and residential central heating. Propane is one of a group of Liquefied Petroleum Gases (LPG). 	<ul style="list-style-type: none"> Vapours may cause dizziness or asphyxiation without warning. Some may be irritating if inhaled at high concentrations. Contact with gas or liquefied gas may cause burns, severe injury and/or frostbite. Fire may produce irritating and /or toxic gases. 	<p>Large Spill Consider initial downwind evacuation for at least 800 metres (1/2 mile)</p>	<p>If a tank, rail car or tank truck is involved in a fire, isolate for 1600 metres (1 mile) in all directions; also, consider initial evacuation for 1600 metres (1 mile) in all directions.</p>	<p>100 m (330 ft)</p>
Butane					
Liquified Petroleum Gas (LPG)					

CANUTEC 2024 – Hazard Reference Table					
Petroleum Crude Oil	<ul style="list-style-type: none"> Brown to black. Viscous liquid. May contain or release poisonous hydrogen sulfide gas. Extremely flammable liquid and vapour 	<ul style="list-style-type: none"> Inhalation or contact with material may irritate or burn skin and eyes. Fire may produce irritating, corrosive and/or toxic gases. Vapors may cause dizziness or suffocation. 	<p>Large Spill Consider initial downwind evacuation for at least 300 metres (1000 ft).</p>	If tank, rail car or tank truck is involved in a fire, isolate for 800 metres (1/2 mile) in all directions; also, consider initial evacuation for 800 metres (1/2 mile) in all directions.	50 m (150 ft)
Hydrogen Sulphide (H ₂ S)	<ul style="list-style-type: none"> Flammable – explosive when mixed with air. Forms SO₂ when combusted. Rotten egg smell at low concentrations. Inhibits olfactory senses at high concentrations. Heavier than air. Will tend to disperse slower in sheltered or low-lying areas. Extremely toxic. 	<ul style="list-style-type: none"> Toxic; extremely hazardous. May be fatal if inhaled or absorbed through skin. Initial odour may be irritating or foul and may deaden your sense of smell. Contact with gas or liquefied gas may cause burns, severe injury and/or frostbite. Fire will produce irritating, corrosive and/or toxic gases. 	<p>Small Spill – Day Consider initial downwind evacuation for at least 0.1 km. (100 m)</p> <p>Small Spill – Night Consider initial downwind evacuation for at least 0.4 km (400 m)</p> <p>Large Spill – Day Consider initial downwind evacuation for at least 2.1 km (2100 m)</p> <p>Large Spill – Night Consider initial downwind evacuation for at least 5.4 km (5400 m)</p>	If tank, rail car or tank truck is involved in a fire, isolate for 1600 metres (1 mile) in all directions; also, consider initial evacuation for 1600 metres (1 mile) in all directions.	100 m (330 ft)
Petroleum sour crude oil, flammable, toxic	<ul style="list-style-type: none"> Rotten egg smell at low concentrations. Inhibits olfactory senses at high concentrations. Brown to black. Viscous liquid. May contain or release poisonous hydrogen sulfide gas. Extremely flammable liquid and vapour 	<ul style="list-style-type: none"> Toxic; extremely hazardous. May be fatal if inhaled or absorbed through skin. Initial odour may be irritating or foul and may deaden your sense of smell. Contact with gas or liquefied gas may cause burns, severe injury and/or frostbite. Fire will produce irritating, corrosive and/or toxic gases. Inhalation or contact with material may irritate or burn skin and eyes. Fire may produce irritating, corrosive and/or toxic gases. Vapors may cause dizziness or suffocation. 	<p>Small Spill – Day Consider initial downwind evacuation for at least 0.1 km. (100 m)</p> <p>Small Spill – Night Consider initial downwind evacuation for at least 0.2 km (200 m)</p> <p>Large Spill – Day Consider initial downwind evacuation for at least 0.5 km (500 m)</p> <p>Large Spill – Night Consider initial downwind evacuation for at least 0.7 km (700 m)</p>	If tank, rail car or tank truck is involved in a fire, isolate for 800 metres (1/2 mile) in all directions; also, consider initial evacuation for 800 metres (1/2 mile) in all directions.	100 m (330 ft)

CANUTEC 2024 – Hazard Reference Table

<p>Benzene</p>	<ul style="list-style-type: none"> • Benzene is a simple aromatic or “ring shaped” hydrocarbon. • Freezing Point is 5°C, Higher than water. • Boiling Point is 80°C, Lower than water. • Density is 0.8 g/ml @ 20°C, Liquid Benzene will float on water. • Vapor Pressure is 10 kPa @ 25°C, Strong tendency to evaporate to air. • Half-life Degradation (air) – 0.1 to 20 days. Degraded by sun and other chemicals. • Extremely Flammable. • Use caution with all ignition sources. 	<ul style="list-style-type: none"> • Short term benzene concentrations may approach or exceed Occupational Health and Safety (OHS) regulation limits in close proximity (on the facility site), depending on wind conditions and dispersion conditions. • In Alberta, the Occupational Exposure Limit (OEL) for benzene is 1 ppm. High concentration short-term exposures (greater than 3200 mg/m³ (1000 ppb) over an 8-hour period) are very unlikely to occur during worker activities. Exposure could conceivably involve inhalation, ingestion, and/or skin contact. • Benzene is not easily absorbed through skin contact. The absorption of benzene vapor through the skin is unlikely to be significant at concentrations below 25 ppm. 	<p>Large Spill Consider initial downwind evacuation for at least 300 metres (1000 ft).</p>	<p>If tank, rail car or tank truck is involved in a fire, isolate for 800 metres (1/2 mile) in all directions; also, consider initial evacuation for 800 metres (1/2 mile) in all directions.</p>	<p>50 m (150 ft)</p>
----------------	---	--	---	---	--------------------------

CANUTEC 2024 – Hazard Reference Table					
Chlorine	<ul style="list-style-type: none"> A greenish-yellow gas or amber liquid with a pungent odor. Chlorine gas is two and one-half times as heavy as air, has an intensely disagreeable suffocating odor, and is exceedingly poisonous. Physical State (Liquid or gas) Liquefied, non-flammable gas under pressure, but is a strong oxidizer. Most combustibles will burn in chlorine forming toxic gases. Chlorine dissolves when mixed with water. It can also escape from water and enter air under certain conditions. Most direct releases of chlorine to the environment are to air and to surface water. 	<ul style="list-style-type: none"> Inhalation is the major potential route of exposure. Chlorine is a respiratory irritant. Chlorine is irritating and can be corrosive to the eyes, skin, and mucous membranes. Symptoms of exposure include burning of eyes, nose, and mouth. Other symptoms of overexposure can include nausea, vomiting, dizziness, shortness of breath and chest pain. Exposures to higher concentrations can cause unconsciousness and death. Pulmonary edema and chemical pneumonia can develop and may occur hours after exposure. Chlorine has an IDLH (Immediately Dangerous to Life or Health) concentration of 10 ppm. Causes burns. Chlorine vapors can cause irritation, burning and blisters. 	<p>First ISOLATE in all Directions 60 m (200 ft)</p>	<ul style="list-style-type: none"> Substance does not burn but will support combustion. Vapors from liquefied gas are initially heavier than air and spread along ground. These are strong oxidizers and will react vigorously or explosively with many materials including fuels. May ignite combustibles (wood, paper, oil, clothing, etc.). Some will react violently with air, moist air and/or water. Cylinders exposed to fire may vent and release toxic and/or corrosive gas through pressure relief devices. Containers may explode when heated. Ruptured cylinders may rocket. 	100 m (330 ft)
			<p>Small Spill – Day Consider initial downwind evacuation for at least 0.3 km. (0.2 mi)</p> <p>Small Spill – Night Consider initial downwind evacuation for at least 1.1 km (0.7 mi)</p> <p>See table below</p>		

Hazardous Product	Transport Container	First ISOLATE in all Directions		Initial Isolation and Protective Action Distances											
				Day						Night					
				Low wind < 6 mph = < 10 km/h		Moderate wind 6-12 mph = 10 - 20 km/h		High wind > 12 mph = > 20 km/h		Low wind < 6 mph = < 10 km/h		Moderate wind 6-12 mph = 10 - 20 km/h		High wind > 12 mph = > 20 km/h	
Meters	Feet	Km	Miles	Km	Miles	Km	Miles	Km	Miles	Km	Miles	Km	Miles		
Chlorine (UN 1017) Sulphur Dioxide (UN 1079)	Rail Tank Car	1000	3000	9.9	6.2	6.4	4.0	5.1	3.2	11+	7+	9.0	5.6	6.7	4.2
	Highway tank truck or trailer	600	2000	5.8	3.6	3.4	2.1	2.9	1.8	6.7	4.3	5.0	3.1	4.1	2.5
	Multiple ton cylinders	300	1000	2.1	1.3	1.3	0.8	1.0	0.6	4.0	2.5	2.4	1.5	1.3	0.8
	Multiple small cylinders or single ton cylinder	150	500	1.5	0.9	0.8	0.5	0.5	0.3	2.9	1.8	1.3	0.8	0.6	0.4

11.4 Legal Survey Description (LSD) Reference Tool

- Each township (6 mile x 6 mile) is divided into 36 sections (1 mile x 1 mile)
- Each section is divided into 16 legal sub-divisions (LSD)
- Each section is divided into four quarters (N.W., N.E., S.W., and S.E.)

The numbering of sections and LSDs is shown below:

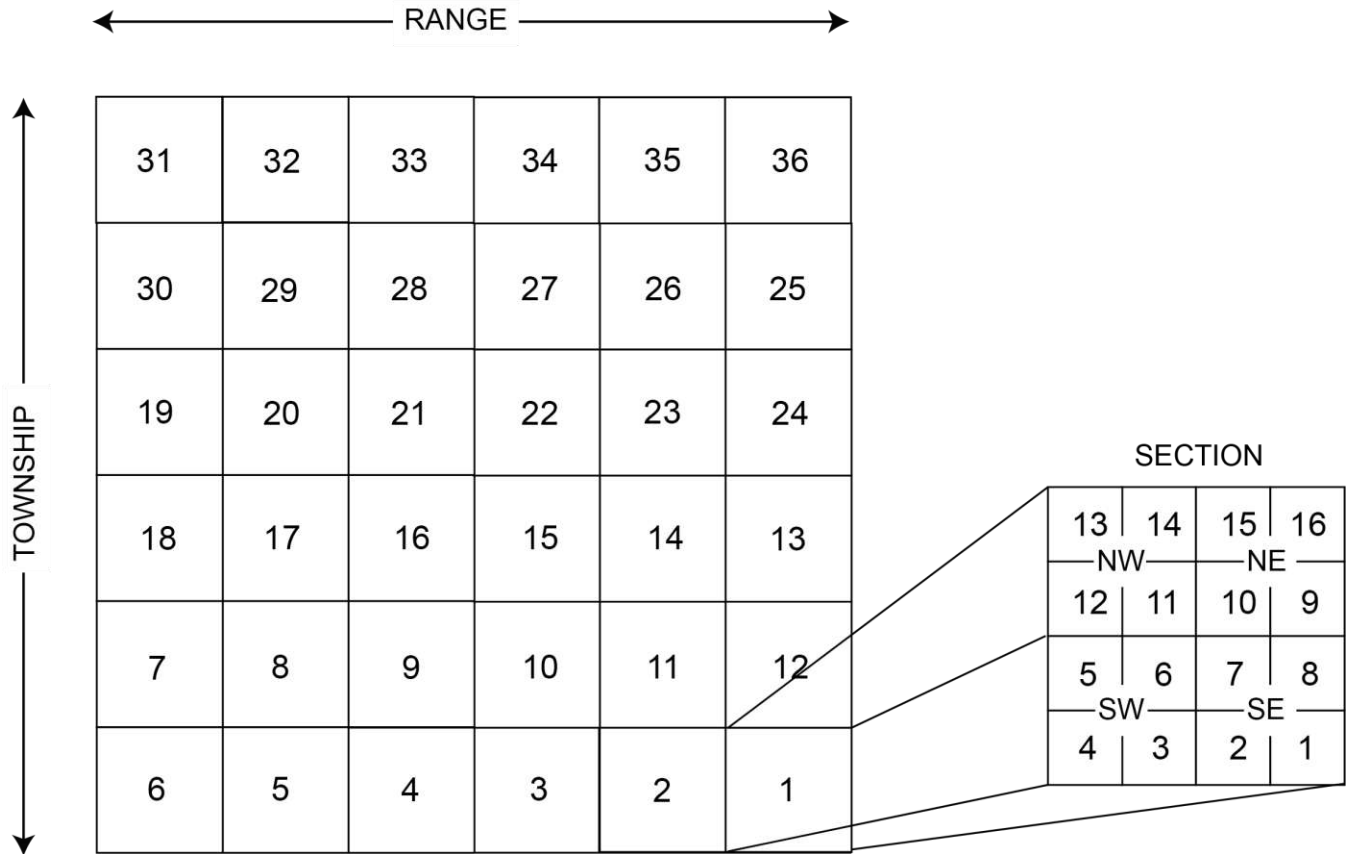

- Townships increase in number from South to North starting at the Canada - USA border.
- Ranges increase in number from East to West within a Meridian. A Range is one Township wide (6 miles).
- Meridians run from the North Pole to the South Pole and are spaced every four degrees. The principal Meridian in Canada originates in Central Manitoba and increases West or East from there.
- Legal land description is listed in the following order:

	LSD	Section	Township	Range	Meridian
Example:	02	01	38	09	West of the 4th

11.5 National Topographic System (NTS) Reference Tool

Based on the national topographic series map numbering system terms as follows:

- Primary Quadrangle:** A 4° x 8° in geodetic latitude and longitude (e.g. Primary Quadrangle 93).
- Lettered Quadrangle:** 1/16 of a Primary Quadrangle 1° in latitude by 2° in longitude, lettered A to P (e.g. 93-P).
- N.T.S. Grid Area:** 1/16 of Lettered Quadrangle 15' in latitude by 30' in longitude, numbered 1 to 16 (e.g. 93-P-9).
- Block:** An area 1/12 of an NTS map 5' in latitude by 7'30" in longitude, lettered A to L (e.g. H/93-P-9).
- Unit:** A block is divided into 100 numbered parts, 10 to a side, each part called a unit and has a latitudinal extent of 30" and longitudinal extend of 45" (e.g. 29-H/93-P-9).
- Quarter Section:** ¼ of a Unit, lettered a to d (e.g. a-29-H/93-P-9).

The area contained by a unit decreases to the north from 86.016 HA at 48° latitude to 64.782 HA at 60° latitude.

Example: a-29-H/94-P-9

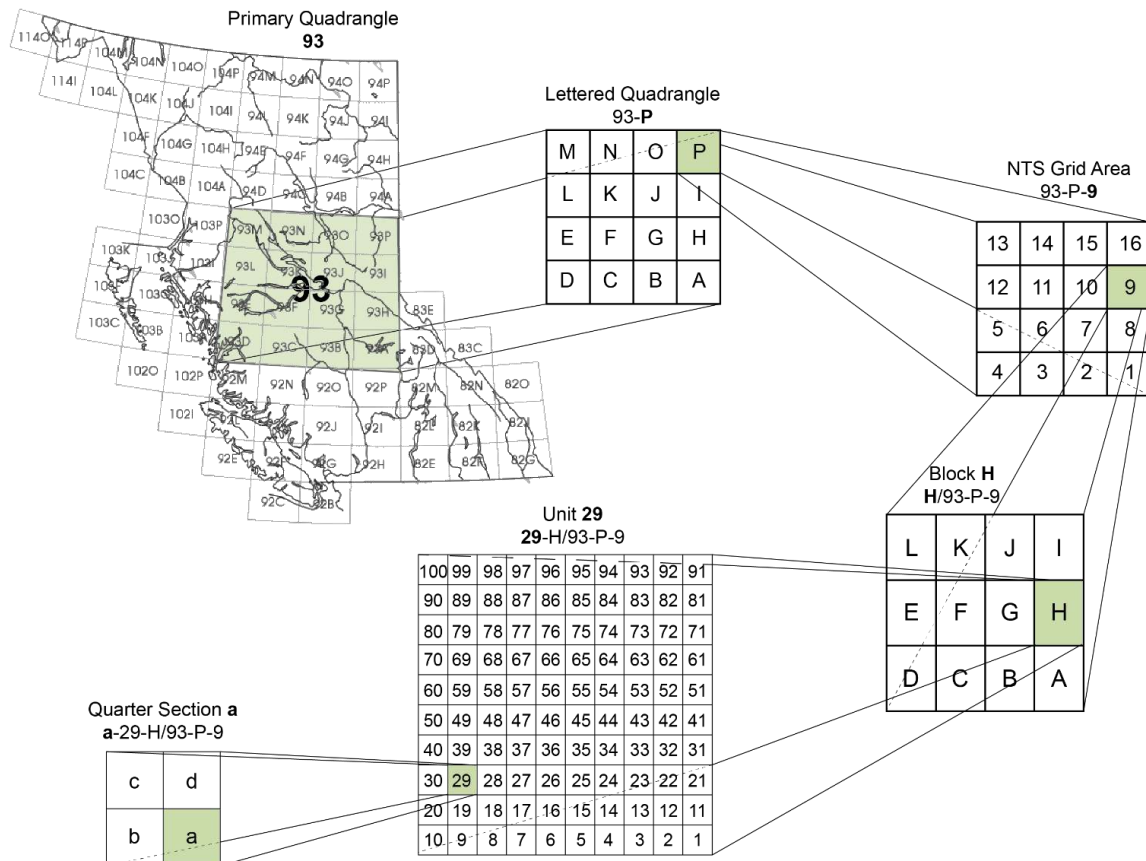

11.6 HVP - Proposed EPZ Distances for Selected Diameters

Pipeline Size		Ethane, Propane, and Butane Mix (no Ethylene)	Ethylene
3"	88.9 mm	250 m	250 m
4"	114.3 mm	300 m	350 m
6"	168.3 mm	500 m	550 m
8"	219.1 mm	700 m	750 m
10"	273.1 mm	900 m	1000 m
12"	323.9 mm	1100 m	1200 m
16"	403.4 mm	1600 m	1600 m

CAPP Companion Planning Guide to ERCB Directive 071, July 2008

11.7 Glossary

- 10³m³ (e³m³): 1000 cubic metres per day.
- Absolute Open Flow: The rate at which a well would produce against a zero sandface back pressure.
- Adjacent to: For the purpose of this plan, refers to the immediate 25 metres.
- Adverse Effect: The impairment of or damage to the environment, human health or safety, or property.
- Agency: A division of government with a specific function offering a particular kind of assistance. Agencies are defined as jurisdictional (having statutory responsibility for incident management) or as assisting or cooperating (providing resources or other assistance).
- Air Quality Monitoring: The measurement of atmospheric concentrations of a gas such as H₂S or SO₂.
- ALS: An abbreviation for Advance Life Support.
- Auto-Ignition Temperature: All NGL products are flammable and will flash at extremely low temperatures. An open flame or spark is not necessary to cause ignition. Any hot surface which exceeds the auto-ignition temperature of a product can cause a fire if the vapours reaching the hot surface are within their flammable range.
- Battery: A group of tanks in the gathering system, they receive oil directly from the wells.
- bbl: An abbreviation for barrel.
- BLS: An abbreviation for Basic Life Support.
- Boiling Liquid Expanding Vapour Explosion (BLEVE): A boiling liquid expanding vapour explosion is usually associated with natural gas liquids and high vapour pressure liquids. This is a type of explosion that can occur when a vessel containing a pressurized liquid is ruptured.
- Booster Pump: A small pump that pulls product from the source of supply and pumps it into the suction, or input of the main pump unit.
- Businesses: Industrial operators, retail suppliers, service providers, trappers, loggers and other entities who normally operate within the EPZ, but do not necessarily reside in the EPZ.

Camp:	A geographical site equipped and staffed to provide sleeping, food, water, and sanitary services to personnel.
Ceiling – Recommended Exposure Limit:	The concentration that should not be exceeded during any part of the working exposure. An employee's exposure to a hazardous substance shall at no time exceed the ceiling value.
CER	Canada Energy Regulator
Chain of Command:	A series of command, control, executive, or management positions in hierarchical order of authority.
Command Staff:	In an incident management organization, the Command Staff consists of the Incident Command and the special staff positions of Officer, Chief and other positions as required, who report directly to the Incident Commander. They may have assistants as needed.
Condensate:	The liquid formed by the condensation of a vapour or gas; specifically, the hydrocarbon liquid separated from natural gas because of changes in temperature and pressure when the gas from the reservoir was delivered to the surface separators.
Control Valve:	A valve that will automatically maintain a predetermined pressure upstream or downstream of the valve or will maintain a controlled flow rate through the valve.
Corporate Emergency Operations Centre (CEOC):	Focal point for the communication of support functions provided by Head Office personnel and (potentially) contract specialists. They should provide advice, direction and logistical support to the Site Command personnel.
Downstream:	With reference to a pumping station, indicates the discharge side of that station.
Emergency Planning Zone (EPZ):	An EPZ is a geographical area surrounding a well, pipeline, or facility containing hazardous product that is an amalgamation of multiple individual HPZ's (Hazard Planning Zones) and requires specific emergency response planning by the licensee. An EPZ includes all entities impacted or potentially impacted as determined by calculations, both on and beyond operating area or lease property.
Emergency Response Plan (ERP):	A comprehensive plan to protect the public that includes criteria for assessing an emergency situation and procedures for mobilizing response personnel and agencies and establishing communication and coordination among the parties.
Emergency Shutdown Valve (ESD):	A valve that blocks the passage of material from both directions and can automatically close when the amount of material passing through the valve exceeding allowable limits.
ERAC:	An abbreviation for Emergency Response Assistance Canada. A not-for-profit emergency preparedness and response organization who develops, implements and responds to Emergency Response Assistance Plans (ERAPs) for more than 300 Plan Participant Members of ERAC.

ERAP:	An ERAP or Emergency Response Assistance Plan is a plan that describes what is to be done in the event of a transportation accident involving certain higher risk dangerous goods. The ERAP is required by the Transportation of Dangerous Goods Regulations (TDGR) for dangerous goods that require special expertise and response equipment to respond to an incident. The plan is intended to assist local emergency responders by providing them with technical experts and specially trained and equipped emergency response personnel at the scene of an incident.
Explosive Limit:	Each gaseous hydrocarbon substance has a minimum lower explosive limit (LEL) and a maximum upper explosive limit (UEL) percentage in the air below or above which combustion will not take place. Explosive limit and flammability limit are used interchangeably. The terms 'too lean' and 'too rich' are used for levels outside of the explosive range.
Facility:	Any building, structure, installation, equipment or appurtenance over which the Regulatory Authority has jurisdiction and that is connected to or associated with the recovery, development, production, handling, processing, treatment or disposal of hydrocarbon-based resources or any associated substances or wastes. This term does not refer to or include wells or pipelines.
Field Separator:	A vessel in the oil and gas field for separating gas, hydrocarbon liquid, and water from each other.
Flammability Limit:	<p>The lower flammability limit is the minimum percentage volume of a combustible gas in an air mixture that will support combustion at certain pressure and temperature conditions.</p> <p>The higher flammability limit is the maximum percentage volume of a combustible gas in an air mixture that will support combustion at certain pressure and temperature conditions.</p> <p>Note: Data for flammability limits is often published for standard atmospheric and temperature conditions. Refer to the Safety Data Sheet (SDS) for specific product information.</p>
Flaring/Venting:	The controlled burning (flare) or release (vent) of natural gas that can't be processed for sale or use because of technical or economic reasons.
Flash Point:	The lowest temperature at which vapours over a volatile combustible substance will ignite when exposed to an external source of ignition (and will continue to burn after the source is removed).
Flexibility:	A principle of ICS that provides a consistent and adjustable framework within which government and private entities at all levels can work together to manage domestic incidents, regardless of their cause, size, location, or complexity. This flexibility applies across all phases of the incident management: prevention, preparedness, response, recovery, and mitigation.
Flow Rate:	The speed in which the product is flowing, computed in cubic metres per second (m ³ /s).
Gathering System:	The network of pipelines, pumps, tanks and other equipment that carry oil and gas to a processing plant or to other separation equipment.
Government Emergency Operations Centre (GEOC):	An operations centre with the capacity to accommodate representatives from each government department.

Hazard:	A situation with potential to cause harm to persons, property, or the environment.
High Vapour Pressure (HVP):	HVP products have a vapour pressure greater than 240 kPa at a temperature of 38° C (34.8 psig at 100 °F). They include ethane, propane, butane, and pentanes plus either as individual products or as a mixture. A leak from a vessel or pipe containing HVP products can result in a BLEVE.
High Vapour Pressure (HVP) Pipeline:	A pipeline system conveying hydrocarbons mixtures or hydrocarbon mixtures in the liquid or quasi-liquid state with a vapour pressure greater than 100 kPa absolute at 38°C, as determined using the Reid method. Some examples are liquid ethane, ethylene, propane, butanes, and pentanes plus.
Hazard Planning Zone (HPZ):	<p>Hazard planning distances are used to identify a geographical area (a hazard planning zone) within which persons, property or the environment may be affected by an emergency. The combined geographic areas of hazard planning zones are used by the applicant or permit holder to identify an EPZ where immediate response actions are required in the event of an emergency.</p> <p>The HPZ has been determined by CANUTEC as the area that requires immediate precautionary measures whereby the spill or leak is to be isolated in all directions for the specified distance.</p>
Hydrogen Sulphide (H ₂ S):	A naturally occurring gas found in a variety of geological formations and also formed by the natural decomposition of organic matter in the absence of oxygen. H ₂ S is colourless, heavier than air, and extremely toxic. In small concentrations it has a rotten egg smell and causes eye and throat irritation.
Hydrogen Sulphide (H ₂ S) Release Rate:	The rate at which the sour gas escapes into the atmosphere is calculated for sour gas wells. The rate is usually given in cubic metres per second (m ³ /s). The size of the EPZ is calculated based on the H ₂ S release rate.
Hydrogen Sulphide (H ₂ S) Release Volume:	The volume of sour gas that escapes into the atmosphere is calculated for facilities that have a defined retention volume. It is usually defined in cubic metres (m ³). EPZ sizes are calculated using the volume of gas that may be released from a facility.
Ignition Team:	A two person team assigned the responsibility of igniting a sour gas plume.
Incident:	An unexpected occurrence or event that requires action by emergency response personnel to prevent or minimize the impacts on the safety and health of people as well as on property and the environment.
Incident Action Plan (IAP):	An Incident Action Plan formally documents incident goals, operations period objectives and the response strategy defined by incident command during emergency response planning.
Incident Classification:	A system that examines the risk level to members of the public following an incident and assigns a level of emergency based on the consequence of the incident and the likelihood of the incident escalating.
Incident Command System (ICS):	The incident command system is a standardized response protocol. It is a combination of facilities, equipment, personnel, procedures and communications operating with a common organization structure with responsibility for the management of assigned resources to effectively accomplish stated objectives pertaining to the incident.

Incident Commander:	The Incident Commander role should be assigned to the most experienced company supervisor or representative at the incident site. The Incident Commander has the responsibility to manage the on-site activities and the implementation of a safe and effective tactical response.
Incident Objectives:	Statements of guidance and direction necessary for selecting the appropriate strategy and tactical direction of resources. Incident objectives are based on realistic expectations of what can be accomplished when all allocated resources have been effectively deployed. Incident objectives must be achievable and measurable, yet flexible enough to allow strategic and tactical alternatives.
Joint Venture Partner:	Two companies working together to combine resources to complete a capital project.
Kick:	A situation where the formation pressure exceeds the static pressure in the well bore allowing formation fluid to enter.
Km:	An abbreviation for kilometre; a unit of length in the metric system, equal to one thousand metres.
kPa:	An abbreviation for kilopascal; it is a measure of force per unit area, defined as one newton per square metre. One kilopascal is about 1% of atmospheric pressure.
Leader:	The ICS title for an individual responsible for a Task Force, Strike Team, or functional unit.
Liaise:	A form of communication for establishing and maintaining mutual understanding and cooperation.
Licensee:	A term used to designate the responsible duty holder (e.g. licensee, operator, company, and applicant).
Liquefied Petroleum Gas (LPG):	Mixture of heavier, gaseous hydrocarbons (butane and propane), liquefied as a portable source of energy.
Local Authority:	Council of a city, town, village, or municipal district. An improvement district or special area. The Settlement Council or a settlement under the Métis Settlements Act. The Band Council of an Indian Band if an agreement has been entered into with the Government of Canada in which it is agreed that the Band Council is a local authority for the purposes of the Disaster Services Act.
Local State of Emergency:	A local state of emergency is authorized for a limited period of time and limited geographical area by members of the municipal authority (city, town, municipal district or county). A local state of emergency grants extraordinary powers to the authorities such as forcibly removing public from an area or preventing the public from entry into a designated area.
Logistics:	Providing resources, material support and other services to support incident management.
Lower Explosive/Flammable Limit (LEL/LFL):	The lowest concentration of gas of vapour (per cent by volume in air) that burns or explodes if an ignition source is present at ambient temperatures.
m ³ :	An abbreviation for cubic metres.

MAWP:	An abbreviation for “maximum actual or allowable working pressure”.
Maximum Operating Pressure (MOP):	The maximum licensed operating pressure for a vessel or pipeline.
mcf:	An abbreviation for one thousand cubic feet of gas.
Mercaptans:	A sulphur containing organic compound with the general formula RSH where R is any radical, especially ethyl mercaptan, C ₂ H ₅ SH.
Mmcf:	An abbreviation for one million cubic feet of gas.
mSv/h	<p>The sievert (symbol: Sv) is a derived unit of ionizing radiation dose in the International System of Units (SI). It is a measure of the health effect of low levels of ionizing radiation on the human body.</p> <p>In the SI system, a millisievert (mSv) is defined as "the average accumulated background radiation dose to an individual for 1 year, exclusive of radon, in the United States." 1 mSv is the dose produced by exposure to 1 milligray (mG) of radiation.</p>
Mobile Air Monitoring Unit:	Personnel with sophisticated portable equipment capable of tracking substances such as H ₂ S or SO ₂ and of measuring very low (ppb) atmospheric concentrations.
MOU:	An abbreviation for Memorandum of Understanding.
Multi-Agency Incident:	An incident where one or more agencies assist a jurisdictional agency or agencies. May be single or Unified Command.
Municipal Emergency Operations Centre (MEOC):	The centre from which responsible municipal officials manage and support operations within their jurisdiction. The MEOC personnel will formulate protective actions and provide public information. The centre should have adequate workspace, maps, status boards, and communications capability.
Mutual Aid Understanding:	An understanding between two or more public and (or) private parties, such as oil and gas companies, service companies, and local authorities that defines each party’s commitment to provide aid and support during an incident.
Natural Gas Liquid (NGL):	These are hydrocarbons liquefied under pressure in field facilities or in gas processing plants. Natural gas liquids include ethane, propane, butanes and pentanes plus, and normally occur as a mixture of these compounds.
Notice to Airmen (NOTAM):	This is a notice issued by Transport Canada. A NOTAM restricts access to airspace in a defined area. NOTAMs are generally issued through the nearest flight service station.
Odour Complaint:	A member of the public has submitted either a written or verbal complaint of an odour problem due to a gas release or venting incident.
Off-Site:	The area beyond the asset property boundary.
OHS:	An abbreviation for Occupational Health and Safety.
Oil Spill Containment and Recovery Unit (OSCAR):	A trailer or truck style unit which contains recovery equipment to assist in spill containment and recovery.
On-Site:	The area within the asset property boundary.

On-Site Command Post (OSCP):	An emergency operations centre established in the immediate vicinity of the incident to provide immediate and direct response to the emergency and initially staffed by company personnel.
Operating Personnel:	Refers to the people working in a given field area.
Operations Section:	The section responsible for all tactical incident operations. In ICS, it normally includes subordinate branches, divisions, and/or groups.
Parts Per Million (ppm):	The unit for measuring the concentration of a particular substance equal to one (1) unit combined with 999,999 other units.
Personal Consultation:	Consultation through face-to-face visits or telephone conversations with identified parties and providing the required information packages.
Personal Protective Equipment (PPE):	Safety equipment used for an individual's protection.
Plain Language:	Common terms and definitions that can be understood by individuals for all responder disciplines. The intent of plain language is to ensure the clear and accurate communication of information during the incident.
Planning Section:	Responsible for the collection, evaluation, and dissemination of operational information related to the incident, and for the preparation and for the documentation of the Incident Action Plan. This section also maintains information on the current and forecasted situation and on the status of resources assigned to the incident.
Plume:	An elongated mobile column of gas or smoke. The term plume is often used to describe the area in which hazardous gas, such as sour gas, disperses into the atmosphere from a facility, well or pipeline. Eventually gases will dilute (with distance away from the source) to concentrations that are not considered hazardous. Plumes are generally elongated shapes that are oriented downwind of the point of the gas release.
ppb:	An abbreviation for parts per billion.
Preparedness:	The range of deliberate, critical tasks and activities necessary to build, sustain, and improve the operational capability to prevent, protect against, respond to, and recover from domestic incidents. Preparedness is a continuous process. Preparedness involves efforts at all levels of government and between government, the private sector and non-government organizations to identify threats and determine vulnerabilities and required resources. Preparedness is operationally focused on establishing guidelines, protocols, and standards for planning, training and exercises, personnel qualification and certification, equipment certification, and publication management.
Public:	Individuals (or groups of people) who may be impacted by an emergency. Example: employees, contractors, nearby residents, emergency response organizations, regulatory agencies, the media, appointed or elected officials, visitors, customers, etc.
Pump Unit:	Consists of an electric motor or engine connected to a centrifugal pump, either directly as in the case of constant speed units, or through a fluid drive, as in the variable speed pump units.

Reception Centre:	A centre established to register evacuees for emergency shelter, to assess their needs, and, if temporary shelter is not required because evacuees will stay elsewhere, to ascertain where they can be contacted; Registration and Support Centre.
Regional Emergency Operations Centre (REOC):	An operations centre established in a suitable off-site location near the emergency to manage the large-scale aspects of the emergency response. It is manned jointly by government and industry personnel.
Regulatory Authority:	The local petroleum Regulatory Authority will participate in the emergency response to all situations involving or threatening oilfield wells, production facilities, or pipelines.
Relief System:	The system for safely relieving excess pressure to avoid exceeding equipment design pressure.
Residence:	A dwelling that is occupied full time or part time.
Response:	Activities that address the short term, direct effects of an incident. Response includes immediate actions to save lives, protect property, and meet basic human needs. Response also includes the execution of emergency operations plans and incident mitigation activities designed to limit the loss of life, personal injury, property damage, and other unfavourable outcomes.
Roadblock	Designated locations where the movement of personnel, equipment, and stakeholders are set-up to monitor the ingress and egress through the EPZ.
Roadblock Team:	Operator or Contract personnel responsible for controlling access to the EPZ.
Rover:	Individual responsible for assisting the evacuation of the Emergency Planning Zone.
Safety Officer:	A member of the Command Staff responsible for monitoring and assessing safety hazards or unsafe situations and for developing measures for ensuring personnel safety.
SCADA:	Acronym for Supervisory Control and Data Acquisition.
SCBA:	Acronym for Self Contained Breathing Apparatus.
Serious Injury:	Can be defined as any of the following: <ul style="list-style-type: none">• An injury that results in death.• A fracture or crush of a major bone.• Penetrating injury to eye, head, neck, chest, abdomen or groin.• Amputation other than a portion of a finger or toe.• Severe haemorrhaging - internal or external.• Third degree burn or any other degree burn with complications.• Unconsciousness.• An injury that results in paralysis (permanent loss of function or sense).
SDS:	Acronym for Safety Data Sheets. A Safety Data Sheet (SDS) is a document that contains information on the potential hazards (health, fire, reactivity and environmental) and how to work safely with a chemical product.
Shelter in Place:	The use of a structure and its indoor atmosphere to temporarily separate individuals from a hazardous outdoor atmosphere. It entails closing all household doors, windows and vents and taking immediate shelter in a readily accessible location that puts as much indoor air and mass between the individual and the hazardous outside air, such as a basement or centrally located medium to small room, and trying to make it as airtight as possible by shutting off all ventilation/HVAC systems and

	extensively sealing the shelter's doors and windows from all outside air contaminants with damp towels, or if available, plastic sheeting and adhesive tape.
SITREP:	An abbreviation for Situation Report.
Solution Gas:	Gas that originates from the liquid phase in an oil reservoir.
Sour:	Liquids and gases are said to be "sour" if they contain hydrogen sulphide (H ₂ S), carbon dioxide (CO ₂), and/or mercaptans over a specified level.
Sour Gas:	Natural gas, including solution gas, containing hydrogen sulphide (H ₂ S).
Sour Gas Facility:	Any facility that produces, processes, or transports sour gas.
Span of Control:	The number of individuals a supervisor is responsible for, usually expressed as a ratio of supervisors to individuals. Under ICS an appropriate span of control is between 1:3 and 1:7 with 1:5 being established as optimum.
Spill:	Means a release or discharge of a substance into the natural environment.
Special Needs:	Those persons for whom early response actions must be taken because they require evacuation assistance, requested early notification, do not have telephones, require transportation assistance, have a language or comprehension barrier, or have specific medical needs. Special needs also include those who decline to give information during the public consultation process and any residences or businesses where contact cannot be made.
Staging Area:	Location established where the resources can be placed while awaiting a tactical assignment. The Operations Section manages Staging Areas.
Stakeholders:	Industry activities often affect surrounding areas and populations. People with an interest in these activities are considered stakeholders. They may include nearby landowners, municipalities, Indigenous communities, recreational land users, other industries, environmental groups, governments and regulators.
Substance:	Any matter that is capable of being dispersed in the environment and that is capable of causing transformations in the environment.
Sulphur:	A yellow, non-metallic chemical element. In its elemental state, it has a crystalline or amorphous form. In many gas streams, sulphur may be found in volatile sulphur compounds, e.g. hydrogen sulphide, sulphur oxides, mercaptans, carbonyl sulphide. Reduction of their concentration levels is necessary for corrosion control and, in many cases, necessary for health and safety reasons.
Sulphur Dioxide (SO ₂):	A colorless, water soluble, suffocating gas formed by burning sulphur in air; also used in the manufacture of sulphuric acid. SO ₂ has a pungent smell similar to a burning match. SO ₂ is extremely toxic at higher concentrations. The molecular weight of SO ₂ is heavier than air; however, typical releases are related to combustion, which makes the gaseous mixture lighter than air (buoyant).
Surface Development:	Dwellings that are occupied full time or part time publicly used development, public facilities, including campgrounds and places of business, and any other surface development where the public may gather on a regular basis. Surface development includes residences immediately adjacent to the EPZ and those from which dwellers are required to egress through the EPZ.

Sump:	An underground tank located at each pump station used to catch products that leak through valves, meters, pump units, seal housing, etc.
Sweet:	Gas containing essentially no objectionable sulphur compounds. Also, the term sweet is used to describe treated gas leaving a sweetening unit.
Tabletop Exercise:	An informal exercise generally used to review resource allocation, roles and procedures for emergency response. It also serves to orientate new personnel to emergency operations without the stress and time constraints of a full scale exercise.
Technical Specialist:	Personnel with special skills that can be used anywhere within the ICS organization.
Telephoner(s):	Personnel assigned the responsibility to contact the area residents and/or users in the event of an Emergency.
Transient:	A person who is temporarily in the response zones (examples: camper, cross-country skier, and hunter).
Trapper:	Holder of a licensed and registered trapline for the purpose of hunting and trapping fur-bearing animals.
Uncontrolled Flow:	A release of product that the licensee cannot shut off at the licensee's discretion.
Unified Command:	The Unified Command is a structure that brings together the "Incident Commanders" of all major organizations involved in the incident in order to coordinate an effective response while at the same time carrying out their own jurisdictional responsibilities. The Unified Command links the organizations responding to the incident and provides a forum for these entities to make consensus decisions.
Urban Center:	A city, town, new town, village, summer village, hamlet, with no fewer than 50 separate buildings, each of which must be an occupied dwelling or any similar development the AER may designate as an urban centre.
Vapour Density:	A measure of the weight of the gas compared to air (air = 1).
Vapour Pressure:	The pressure exerted by the vapour when the rate of evaporation is equal to the rate of condensation of the vapour. All NGL products have vapour pressure greater than atmospheric pressure air and therefore have to be kept under pressure or else they will vaporize.
Well Servicing:	The maintenance procedures performed on a producing or injecting well after the well has been completed and operations have commenced. Well servicing activities are generally conducted to maintain or enhance well productivity or injectivity.
Workovers:	The process of re-entering an existing well to perform remedial action that will restore or improve the productivity or injectivity of the target formation.

12.0 OPERATIONS

For operations information, refer to the operation area's specific Emergency Response Plan binder in conjunction with the correlating operation area's specific Rights Holders & Stakeholder Information binder.

12.0 OPERATIONS

Printing Department: Insert top tab.



**REGISTERED SUPPLEMENTS
EMERGENCY RESPONSE PLANS**

**TUPPER MAIN
ADMINISTRATIVE SECTION**

Prepared by:



March 2026

The purpose of a Registered Supplement ERP is to supplement the Core ERP with field-specific information that enhances the ability of response personnel by providing them with key area emergency response information.

MANAGEMENT OF CHANGE LOG

Annual Review Date: March 31, 2026
Next Annual Review Date: March 31, 2027
Date of Update Inserted Into ERP: _____
Signature: _____

Date Completed (DD/MMM/YYYY)	Revision #	Section(s) Updated	Description	Revision ¹	Annual Update ²
31/March/2026	4	Sec 12	Verified and updated entire Tupper Main & Tupper West Registered Supplements Updated entire Tupper Main & Tupper West Stakeholder Binder.	<input type="checkbox"/>	<input checked="" type="checkbox"/>
29/April/2025	3	Sec 12	Moved the Operations Section to be Section 12. Verified and updated entire Tupper Main & Tupper West Registered Supplement. Updated entire Tupper Main & Tupper West Stakeholder Binder.	<input type="checkbox"/>	<input checked="" type="checkbox"/>
13/May/2024	2	10.1.10 10.1.11 10.1.13	Updated Public Summary section. Updated stakeholder binder. Updated Tupper Main field map.	<input checked="" type="checkbox"/>	<input type="checkbox"/>
29/April/2024	1	Sec 10	Verified and updated entire field supplement.	<input type="checkbox"/>	<input checked="" type="checkbox"/>
30/April/2023	New	All	New Registered Supplement	<input type="checkbox"/>	<input checked="" type="checkbox"/>

¹ **Revision:** An interim revision to the ERP when significant changes occur to Company personnel or infrastructure (drilling, facilities, pipelines). A revision does not replace the requirement for an annual update.

² **Annual Update:** A comprehensive update to all sections of the ERP. The entire document is reviewed and updated to ensure current distribution list, emergency telephone list, roles and responsibilities, mutual aid agreements, response agencies information, government support information, asset tables, safety equipment, and maps. In a Registered Site Specific ERP, the stakeholder database is also verified, a hazard assessment is conducted, and area user contact information is updated.

Registered Supplement Table of Contents

12.0 OPERATIONS	1
Tupper Main Registered Supplement	1
12.1 Tupper Main Field Area	1
12.2 Tupper Main CER Regulated Pipeline.....	1
12.4 Supplemental Field Information	1
12.4.1 Field Specific Response Actions.....	1
12.4.2 Air Monitoring.....	3
12.4.3 Mutual Aid.....	4
12.4.4 Authority Roles Coordination	6
12.4.5 Hazard Risk Analysis Results	15

Registered Supplement Distribution List

This Distribution List includes Tupper Main & Tupper West distribution information.

The following individuals will have a copy of this Emergency Response Plan for use as a reference document in the event of an emergency arising from Company operations.

Note: All NorthRiver personnel, corporate and field operators not listed in the distribution list have access to the required ERPs digitally.

* Binder 1 is the Core Plan. Binder 2 is the Registered Supplement. Binder 3 is the Rights Holders & Stakeholder Information.

[Redacted]									
[Redacted]	[Redacted]	[Redacted]	[Redacted]	[Redacted]	[Redacted]	[Redacted]	[Redacted]	[Redacted]	[Redacted]
[Redacted]	[Redacted]	[Redacted]	[Redacted]	[Redacted]	[Redacted]	[Redacted]	[Redacted]	[Redacted]	[Redacted]
[Redacted]	[Redacted]	[Redacted]	[Redacted]	[Redacted]	[Redacted]	[Redacted]	[Redacted]	[Redacted]	[Redacted]
[Redacted]	[Redacted]	[Redacted]	[Redacted]	[Redacted]	[Redacted]	[Redacted]	[Redacted]	[Redacted]	[Redacted]
[Redacted]	[Redacted]	[Redacted]	[Redacted]	[Redacted]	[Redacted]	[Redacted]	[Redacted]	[Redacted]	[Redacted]
[Redacted]	[Redacted]	[Redacted]	[Redacted]	[Redacted]	[Redacted]	[Redacted]	[Redacted]	[Redacted]	[Redacted]
[Redacted]	[Redacted]	[Redacted]	[Redacted]	[Redacted]	[Redacted]	[Redacted]	[Redacted]	[Redacted]	[Redacted]
[Redacted]	[Redacted]	[Redacted]	[Redacted]	[Redacted]	[Redacted]	[Redacted]	[Redacted]	[Redacted]	[Redacted]

[Redacted]									
[Redacted]	[Redacted]	[Redacted]	[Redacted]	[Redacted]	[Redacted]	[Redacted]	[Redacted]	[Redacted]	[Redacted]
[Redacted]	[Redacted]	[Redacted]	[Redacted]	[Redacted]	[Redacted]	[Redacted]	[Redacted]	[Redacted]	[Redacted]
[Redacted]	[Redacted]	[Redacted]	[Redacted]	[Redacted]	[Redacted]	[Redacted]	[Redacted]	[Redacted]	[Redacted]
[Redacted]	[Redacted]	[Redacted]	[Redacted]	[Redacted]	[Redacted]	[Redacted]	[Redacted]	[Redacted]	[Redacted]
[Redacted]	[Redacted]	[Redacted]	[Redacted]	[Redacted]	[Redacted]	[Redacted]	[Redacted]	[Redacted]	[Redacted]
[Redacted]	[Redacted]	[Redacted]	[Redacted]	[Redacted]	[Redacted]	[Redacted]	[Redacted]	[Redacted]	[Redacted]
[Redacted]	[Redacted]	[Redacted]	[Redacted]	[Redacted]	[Redacted]	[Redacted]	[Redacted]	[Redacted]	[Redacted]

[REDACTED]

[REDACTED]	[REDACTED]	[REDACTED]	[REDACTED]			[REDACTED]		[REDACTED]	[REDACTED]
			[REDACTED]	[REDACTED]	[REDACTED]	[REDACTED]	[REDACTED]		
[REDACTED]	[REDACTED]	[REDACTED]	[REDACTED]	[REDACTED]	[REDACTED]	[REDACTED]	[REDACTED]	[REDACTED]	[REDACTED]
[REDACTED]	[REDACTED]	[REDACTED]	[REDACTED]	[REDACTED]	[REDACTED]	[REDACTED]	[REDACTED]	[REDACTED]	[REDACTED]
[REDACTED]	[REDACTED]	[REDACTED]	[REDACTED]	[REDACTED]	[REDACTED]	[REDACTED]	[REDACTED]	[REDACTED]	[REDACTED]
[REDACTED]	[REDACTED]	[REDACTED]	[REDACTED]	[REDACTED]	[REDACTED]	[REDACTED]	[REDACTED]	[REDACTED]	[REDACTED]
[REDACTED]	[REDACTED]	[REDACTED]	[REDACTED]	[REDACTED]	[REDACTED]	[REDACTED]	[REDACTED]	[REDACTED]	[REDACTED]
[REDACTED]	[REDACTED]	[REDACTED]	[REDACTED]	[REDACTED]	[REDACTED]	[REDACTED]	[REDACTED]	[REDACTED]	[REDACTED]
[REDACTED]	[REDACTED]	[REDACTED]	[REDACTED]	[REDACTED]	[REDACTED]	[REDACTED]	[REDACTED]	[REDACTED]	[REDACTED]
[REDACTED]	[REDACTED]	[REDACTED]	[REDACTED]	[REDACTED]	[REDACTED]	[REDACTED]	[REDACTED]	[REDACTED]	[REDACTED]
[REDACTED]	[REDACTED]	[REDACTED]	[REDACTED]	[REDACTED]	[REDACTED]	[REDACTED]	[REDACTED]	[REDACTED]	[REDACTED]
[REDACTED]	[REDACTED]	[REDACTED]	[REDACTED]	[REDACTED]	[REDACTED]	[REDACTED]	[REDACTED]	[REDACTED]	[REDACTED]
[REDACTED]	[REDACTED]	[REDACTED]	[REDACTED]	[REDACTED]	[REDACTED]	[REDACTED]	[REDACTED]	[REDACTED]	[REDACTED]
[REDACTED]	[REDACTED]	[REDACTED]	[REDACTED]	[REDACTED]	[REDACTED]	[REDACTED]	[REDACTED]	[REDACTED]	[REDACTED]
[REDACTED]	[REDACTED]	[REDACTED]	[REDACTED]	[REDACTED]	[REDACTED]	[REDACTED]	[REDACTED]	[REDACTED]	[REDACTED]
[REDACTED]	[REDACTED]	[REDACTED]	[REDACTED]	[REDACTED]	[REDACTED]	[REDACTED]	[REDACTED]	[REDACTED]	[REDACTED]
[REDACTED]	[REDACTED]	[REDACTED]	[REDACTED]	[REDACTED]	[REDACTED]	[REDACTED]	[REDACTED]	[REDACTED]	[REDACTED]

[REDACTED]

[REDACTED]	[REDACTED]	[REDACTED]	[REDACTED]			[REDACTED]		[REDACTED]	[REDACTED]
			[REDACTED]	[REDACTED]	[REDACTED]	[REDACTED]	[REDACTED]		
[REDACTED]	[REDACTED]	[REDACTED]	[REDACTED]	[REDACTED]	[REDACTED]	[REDACTED]	[REDACTED]	[REDACTED]	[REDACTED]

ERP Types
 Paper, Memory Stick, Digital

Tupper Main Registered Supplement**Printing Department: Remove this page, replace with Red tab.**



Non-Confidential

TUPPER MAIN REGISTERED SUPPLEMENT

EMERGENCY RESPONSE PLAN



24-Hour Emergency Number

1-844-667-8477

BCER Emergency Number

1-800-663-3456

AER Emergency Number

1-800-222-6514

March 2026



**REGISTERED SUPPLEMENT
EMERGENCY RESPONSE PLAN**

TUPPER MAIN AREA

Prepared by:

BLACK GOLD Emergency
Planners Inc

March 2026

The purpose of a Registered Supplement ERP is to supplement the Core ERP with field-specific information that enhances the ability of response personnel by providing them with key area emergency response information.

Government Agencies

Resource	Contact	Cell/24 Hour
Ministry of Emergency Management and Climate Readiness - EMCR	Emergency Coordination Centre 1st call in a Level 1 or greater emergency. The EMCR will forward on the emergency notification onto the BCER On-Call Duty Officer.	1-800-663-3456
British Columbia Energy Regulator	Non-Emergency Office Line 1-250-794-5200	Emergency notification received through EMCR.
Peace River Regional District (Zone B-C-D-E)	Ryan Kirkham Protective Services Manager 1-250-784-3215	1-250-784-3200
	Mike Watkins GM of Community Services 1-250-784-4848	
RCMP - Dawson Creek Detachment	NCO In Charge	911 1-250-784-3700
Health Emergency Management BC, North (HEMBC)	Dawson Creek Health Unit	1-855-554-3622
Ministry of Environment- Peace Regional Office	Environmental Emergency Response Officer	1-250-787-3411
Ministry of Forests - Peace Natural Resource District	District Manager	1-250-784-1200
WorkSafe BC	Occupational Safety Officer Fort St. John	1-250-785-1283
	24 Hour Number	1-888-621-7233 (SAFE)
Ministry of Transportation and Transit- Peace District (Dawson Creek Area)	Shane Bennetts A/Operations Manager South Peace	1-250-784-2363
Argo Road Maintenance Inc.	Service Area 21 - South Peace	1-800-663-7623
BC One Call	Province-wide	1-800-474-6886
Drug and Poison Information Centre	Province-wide	1-800-567-8911
Report a Wildfire	Province-wide	1-800-663-5555 *5555 Cell Phone
Technical Safety BC	Province-wide	1-866-566-7233
BC Hydro	Province-wide	1-800-BCHYDRO (1-800-224-9376) *49376 Cell Phone
Public Services and Procurement Canada - BC Alaska Highway Maintenance	Province-wide	1-250-774-6956
Government of Canada - DFO (Department of Fisheries and Ocean)	Canadian Coast Guard Western Region	1-800-889-8852
Environment and Climate Change Canada	Canada-wide	1-800-668-6767
CN Railway Co. - Police Service	Canada-wide	1-800-465-9239
Canadian Pacific Kansas City (CPKC) - Police Service	Canada-wide	1-800-716-9132
CANUTEC TDG - Emergency Reporting Line	Canada-wide	1-888-226-8832 *666 Cell Phone
Transportation Safety Board (CER Regulated Emergencies)	Pipeline Emergencies	1-819-997-7887
	Non-Pipeline Emergencies	1-403-299-2773
NAV Canada - Notice to Airmen	Canada-wide	1-866-992-7433

Emergency Services

Contact	Location	Telephone
Emergency Response Assistance Plan (ERAP)		
Emergency Response Assistance Canada	Canada-wide	1-800-265-0212
Ambulance - Municipal		
BC Ambulance Service	BC-wide	911 1-800-461-9911 where 911 not available
BC Ambulance Service (SAT Phones)	BC-wide	1-250-374-5937
Ambulance - Oilfield		
911 Industrial Response	Dawson Creek	1-866-694-9111
Firemaster Oilfield Services	BC-wide	1-877-342-3473
Air Ambulance		
BCAS Provincial Air Ambulance Coordination Centre	BC-wide	911 1-800-461-9911 where 911 not available
BCAS Provincial Air Ambulance Coordination Centre (SAT Phones)	BC-wide	1-250-374-5937
STARS [Redacted]	BC-wide	1-888-888-4567 1-403-299-0932 (SAT Phone)
Hospitals		
<i>Emergency Services will determine the nearest hospital to transport patient(s) to in the event of an injury or fatality.</i>		
Fire Fighters - Municipal		
BC Wildfire Service	BC-wide	1-800-663-5555 *5555 on cellphone
Fire Fighters - Oilfield		
Trojan Safety Services Ltd.	Fort St. John	1-250-785-9557
Firemaster Oilfield Services	BC-wide	1-877-342-3473

Spill Response

WCSS - Coop 9	Contact Information
Emergency 24-Hour Number	1-866-541-8888
Chairman: Don Brown Canadian Natural Resources Ltd.	Cell: 1-250-775-0364 don.brown@cnrl.com
Alt. Chairman: Jim Chramosta Shell Canada Limited	Ph: 1-250-794-3426 / Cell: 1-778-256-2685 jim.chramosta@shell.com
Alt. Chairman: Kaylin Salanski NorthRiver Midstream	Ph: 1-250-789-6476 / Cell: 1-250-919-7282 kaylin.salanski@nrm.com
Custodian: NorthRiver Midstream Kaylin Salanski	24hr: 1-250-262-3446 / Cell: 1-250-919-7282
Custodian: Radar Road Rick	24hr: 1-250-774-5332 / Cell: 1-250-775-0036

Note: Please refer to WCSS.ca for all supporting documentation.

Industry Support Services

Contact	Location	Telephone
Air Quality Monitoring Equipment		
AAA Safety and Field Services	Fort St. John	1-250-262-3002
Trojan Safety Services Ltd	Fort St. John	1-250-785-9557
Communication Equipment (Radio/Telephones)		
Epscan Communications	Dawson Creek	1-250-782-9656
North Peace Communications Ltd. (Vincent Communications)	Dawson Creek	1-250-782-6664
Construction Company		
Borek Construction Ltd.	Dawson Creek	1-250-219-1887
Lindberg Construction Inc.	Dawson Creek	1-250-782-6700
Cranes / Picker Services		
SI's Oilfield Hauling Ltd.	Dawson Creek	1-250-784-5533
Sterling Crane	Fort St. John	1-250-263-0082
Helicopters		
Bailey Helicopters Inc.	Fort St. John	1-250-785-2518
Canadian Helicopters Limited	BC-wide	1-780-429-6900
Safety Equipment / Personnel		
911 Industrial Response	Dawson Creek	1-866-694-9111
Firemaster Oilfield Services	BC-wide	1-877-342-3473
Spill Response / Environmental Services		
WCSS	BC-wide	1-866-541-8888
GFL Environmental Inc.	BC-wide	1-800-435-1234
Supply Stores		
Apex Distribution Inc.	Dawson Creek	1-250-786-5497
Brogan Safety Supply Ltd.	Dawson Creek	1-250-784-0116
Tank Rentals		
Total Oilfield Rentals Ltd.	Dawson Creek	1-780-532-1994
Strad Inc.	Dawson Creek	1-866-778-2552
Tank Trucks		
CEDA	Dawson Creek	1-250-784-5151
Swamp Donkey Inc.	Dawson Creek	1-250-219-8370
Vac and Steam Trucks		
Vertex Resource Group Ltd.	Dawson Creek	1-250-719-0353
CEDA	Dawson Creek	1-250-784-5151
Well Control Equipment		
Capstone Blowout Recovery	BC-wide	1-866-347-3911
Firemaster Oilfield Services	BC-wide	1-877-342-3473
Wellsite Accommodations		
Vertex Resource Group Ltd.	Dawson Creek	1-780-532-7707
Total Oilfield Rentals Ltd.	Dawson Creek	1-780-532-1994

Note: The above listed corporate entities are subject to change without notice. Information regarding support services is accurate at time of printing.

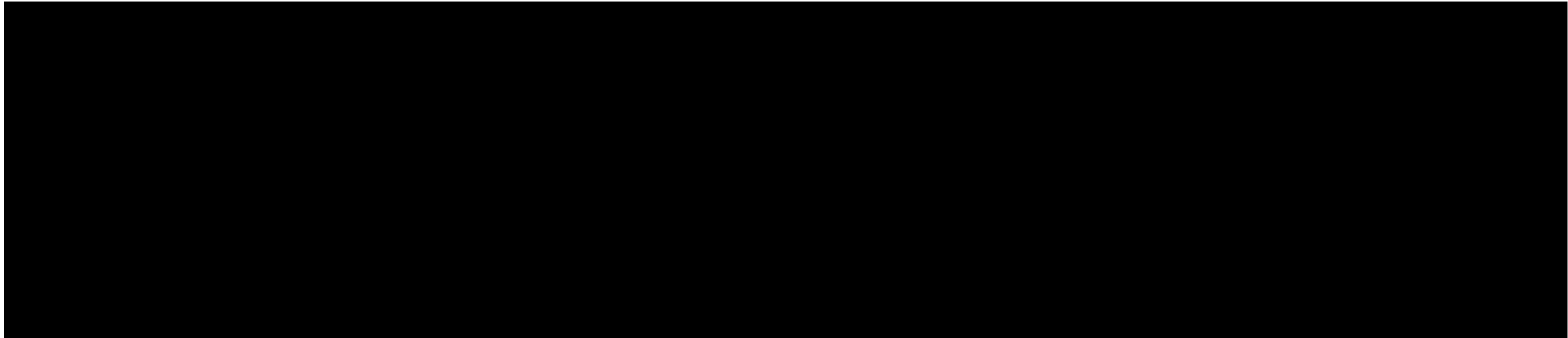

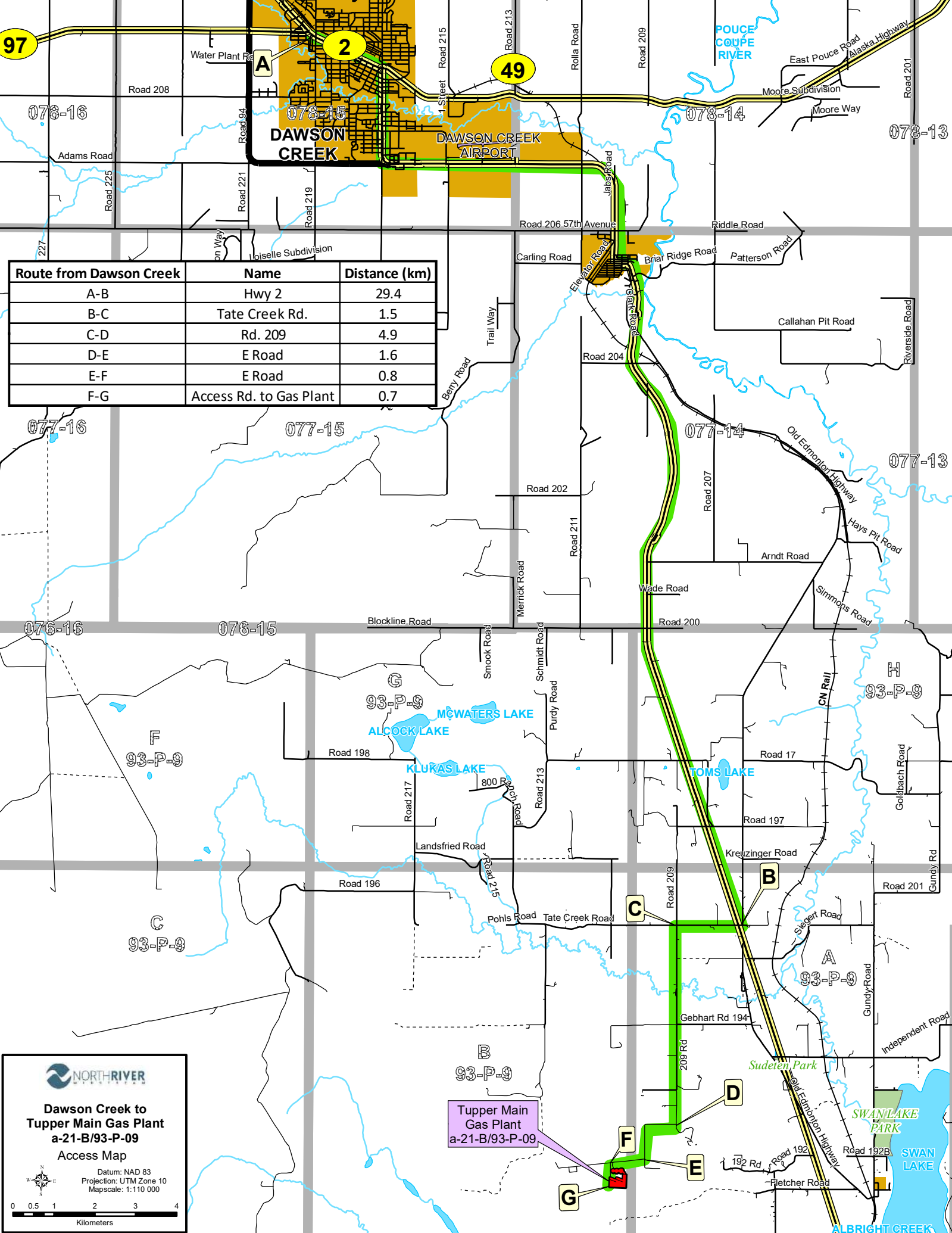

Route from Dawson Creek	Name	Distance (km)
A-B	Hwy 2	29.4
B-C	Tate Creek Rd.	1.5
C-D	Rd. 209	4.9
D-E	E Road	1.6
E-F	E Road	0.8
F-G	Access Rd. to Gas Plant	0.7

NORTHRIVER

Dawson Creek to Tupper Main Gas Plant a-21-B/93-P-09
Access Map

Datum: NAD 83
 Projection: UTM Zone 10
 Mapscale: 1:110 000

0 0.5 1 2 3 4
 Kilometers

Tupper Main Gas Plant
 a-21-B/93-P-09

TUPPER MAIN GAS PLANT a-21-B/93-P-09

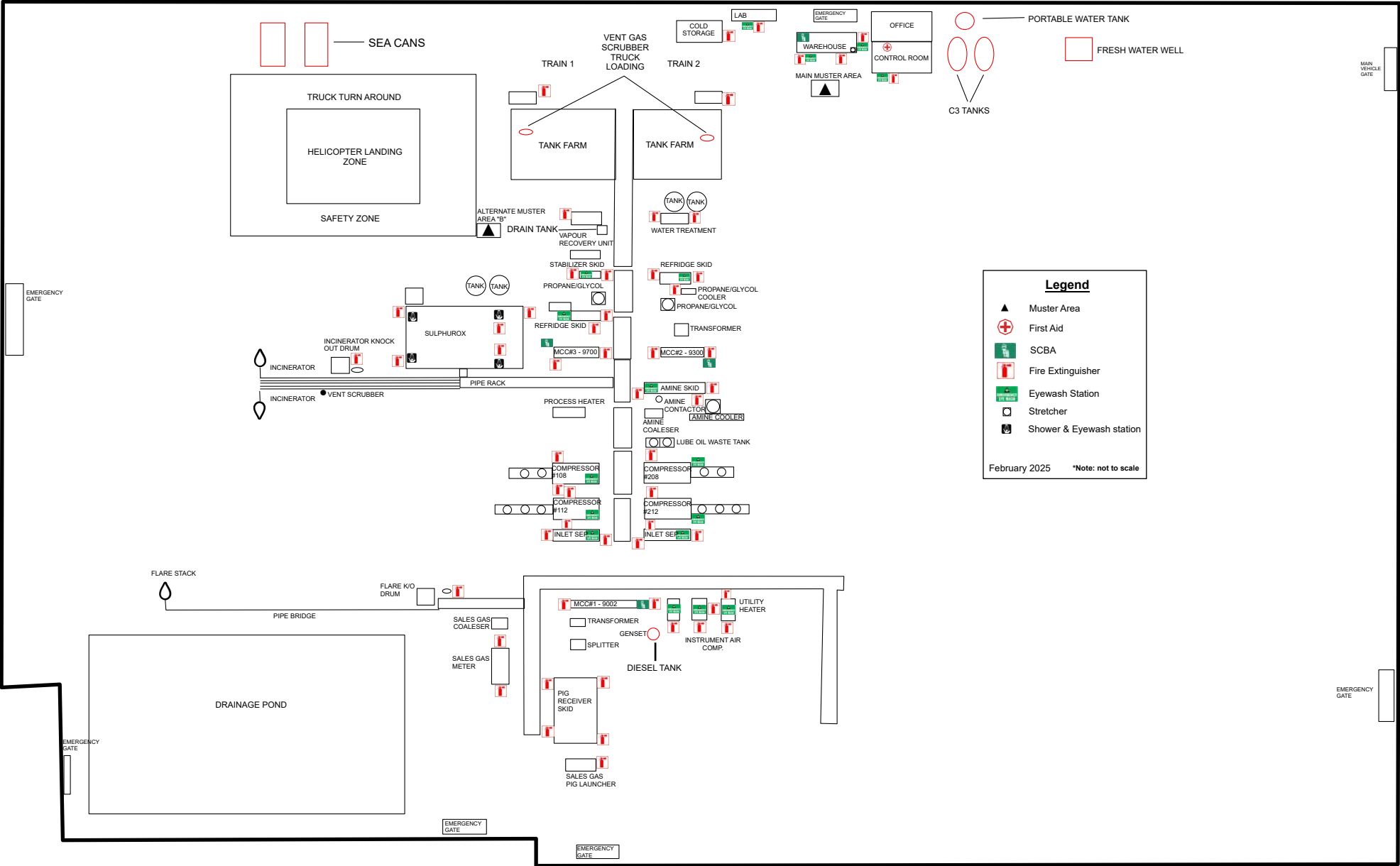

Legend

- ▲ Muster Area
- ⊕ First Aid
- 🧯 SCBA
- 🔥 Fire Extinguisher
- 🚰 Eyewash Station
- 🛖 Stretcher
- 🚿 Shower & Eyewash station

February 2025 *Note: not to scale

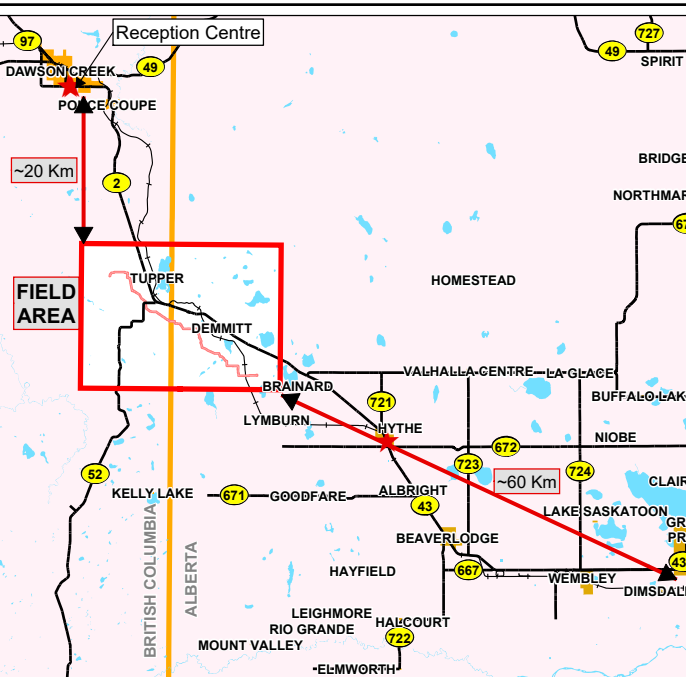

- Northriver Wells**
 - Gas
 - Oil
 - Standing
 - Injection
 - Suspended Gas
 - Suspended Oil
 - Water
 - Bottom Hole
 - Well EPZ
 - Well EAZ
- Northriver Pipelines**
 - Discontinued
 - Sour Gas
 - Natural Gas / Fuel Gas
 - Oil
 - Water
 - HVP / LVP
 - Major Transmission Lines
 - Block Valves
 - Check Valves
 - Pipeline EPZ
 - Pipeline EAZ
- Northriver Facilities**
 - Battery
 - Compressor Station
 - Dehydrator
 - Gas Plant
 - Gathering Point
 - Injection Point
 - Meter Station
 - Pump Station
 - Satellite
 - Facility EPZ
 - Storage HPZ
- Other Symbols**
 - Airfield
 - County Region
 - Health Region
 - RCMP
 - WCSS Cooperative
 - Parks
 - First Nations
 - Trapper Boundaries
 - Guide Outfitters
 - District Lots
 - Range Tenure
 - Cutblocks
 - Contours (m)
 - Water Control Point
 - Critical Water
 - Control Point
 - Egress Area
 - WMU
- Transportation**
 - Secondary Highway
 - High Grade Roads
 - Resource Roads
 - Low Grade / Seasonal
 - Primary Highway
 - Radio Controlled Roads
 - Railways
 - Mile 83 Marker
 - Locked Gates
- Other Operator Wells and Pipelines represented in GREY.**

Map Created by DM May 26, 2022 Revised by LN February 06, 2026

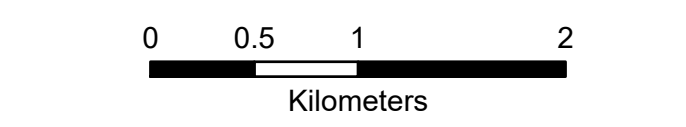

Datum: NAD 83 Projection: UTM Zone 11 Mapscale: 1:36 000

NorthRiver Midstream Inc.

Tupper Main

Emergency Planning Zone Map

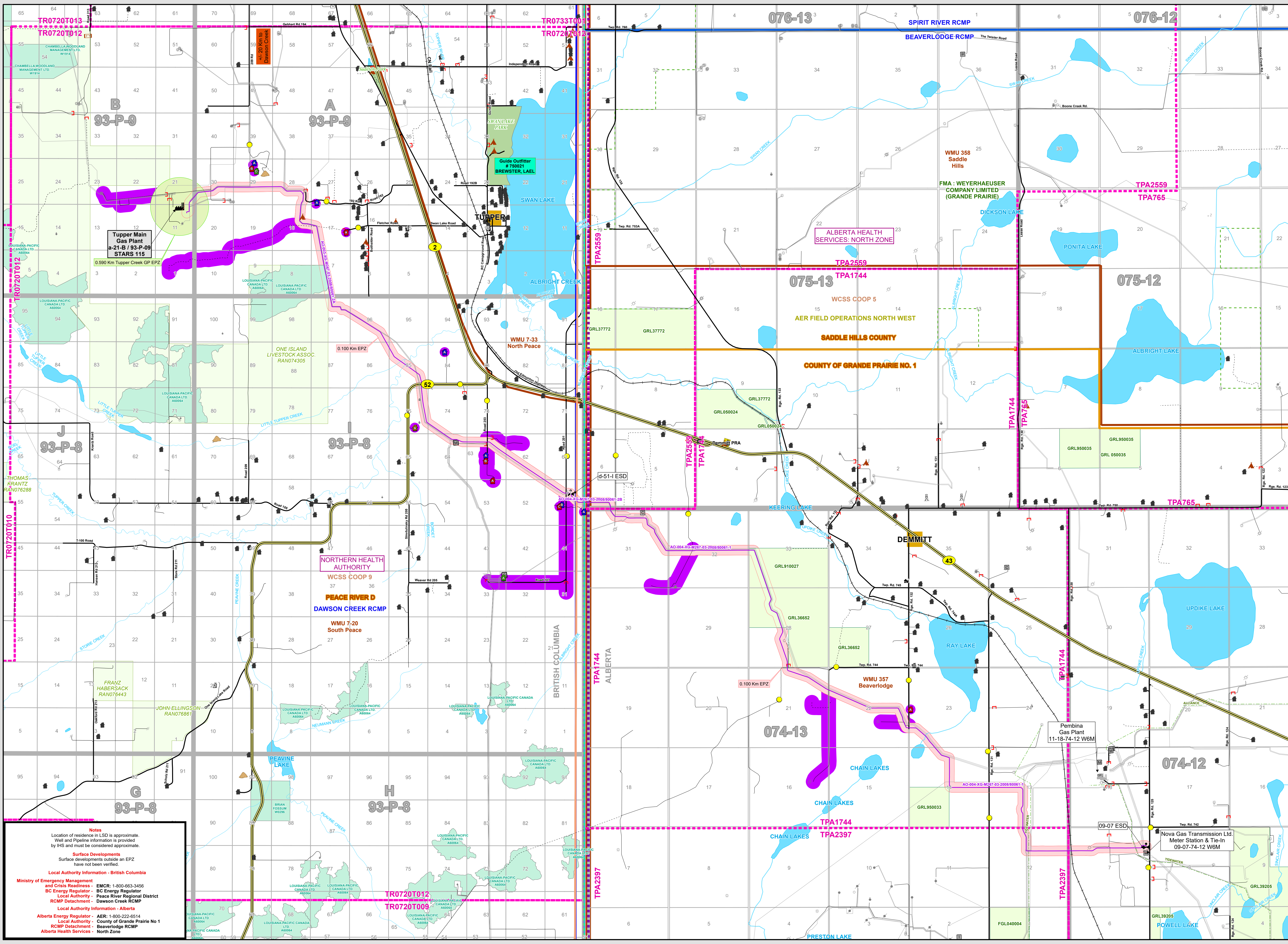

Notes
 Location of residence in LSD is approximate. Well and Pipeline information is provided by IHS and must be considered approximate.

Surface Developments
 Surface developments outside an EPZ have not been verified.

Local Authority Information - British Columbia
 Ministry of Emergency Management and Crisis Readiness - EMCR: 1-800-663-3456
 BC Energy Regulator - BC Energy Regulator
 Local Authority - Peace River Regional District
 RCMP Detachment - Dawson Creek RCMP

Local Authority Information - Alberta
 Alberta Energy Regulator - AER: 1-800-222-6514
 Local Authority - County of Grande Prairie No 1
 RCMP Detachment - Beaverlodge RCMP
 Alberta Health Services - North Zone

Government Agencies – British Columbia

Resource	Contact	Cell/24 Hour
Ministry of Emergency Management and Climate Readiness - EMCR	Emergency Coordination Centre 1st call in a Level 1 or greater emergency. The EMCR will forward on the emergency notification onto the BCER On-Call Duty Officer.	1-800-663-3456
British Columbia Energy Regulator	Non-Emergency Office Line 1-250-794-5200	Emergency notification received through EMCR.
Peace River Regional District (Zone B-C-D-E)	Ryan Kirkham Protective Services Manager 1-250-784-3215 Mike Watkins GM of Community Services 1-250-784-4848	1-250-784-3200
RCMP - Dawson Creek Detachment	NCO In Charge	911 1-250-784-3700
Health Emergency Management BC, North (HEMBC)	Dawson Creek Health Unit	1-855-554-3622
Ministry of Environment- Peace Regional Office	Environmental Emergency Response Officer	1-250-787-3411
Ministry of Forests - Peace Natural Resource District	District Manager	1-250-784-1200
WorkSafe BC	Occupational Safety Officer Fort St. John	1-250-785-1283
	24 Hour Number	1-888-621-7233 (SAFE)
Ministry of Transportation and Transit- Peace District (Dawson Creek Area)	Shane Bennetts A\Operations Manager South Peace	1-250-784-2363
Argo Road Maintenance Inc.	Service Area 21 - South Peace	1-800-663-7623
BC One Call	Province-wide	1-800-474-6886
Drug and Poison Information Centre	Province-wide	1-800-567-8911
Report a Wildfire	Province-wide	1-800-663-5555 *5555 Cell Phone
Technical Safety BC	Province-wide	1-866-566-7233
BC Hydro	Province-wide	1-800-BCHYDRO (1-800-224-9376) *49376 Cell Phone
Public Services and Procurement Canada - BC Alaska Highway Maintenance	Province-wide	1-250-774-6956

Government Agencies – Alberta

Resource	Contact	Cell/24 Hour
Alberta Energy Regulator	Energy and Environmental Emergency 24-Hour Response Line	1-800-222-6514 1-780-422-4505 (Outside AB)
County of Grande Prairie No. 1	Trevor Grant, Fire Chief 1-780-532-9727	Cell 1-780-882-2975 24-Hr 1-780-814-0280
	Chad Cormack, Deputy Fire Chief 1-780-532-9727	
	Joulia Whittleton, DEM 1-780-532-3722	
	Lee Brachman, Deputy DEM 1-780-532-9727	
RCMP - Beaverlodge	NCO In Charge	911 1-780-354-2955
Alberta Health Services	Province-wide	1-844-755-1788
Alberta Emergency Management Agency	Provincial Emergency Coordination Centre (PECC)	1-866-618-2362 24/7 Emergency Assistance
	Sandra Zarate, Manager, Public Alerting and Communication Team	1-587-341-0298
Alberta Emergency Management Agency, Northwest Region	Alan Stebbing, Emergency Management Field Officer 1-587-783-9201	1-866-618-2362 24/7 Emergency Assistance
	Chris Graham, Emergency Management Field Officer 1-825-993-4235	
Ministry of Environment and Protective Areas (EPA)	Energy & Environment Response Line	1-800-222-6514 1-780-422-4505 (Outside AB)
Ministry of Environment and Protected Areas (EPA)	Peace Region	1-800-222-6514
Alberta Agriculture and Irrigation - 310-FARM	Provincial Resource Agents	310-FARM (3276) 1-403-742-7901 (Outside AB)
Alberta Wildfire - Report a Wildfire	Province-wide	310-FIRE (3473)
Alberta Occupational Health and Safety	Province-wide	1-866-415-8690
Alberta Edge (Environment and Dangerous Goods Emergencies)	Province-wide	1-800-272-9600
Highway Maintenance Contractors	Ledcor Highways Ltd.	1-866-453-3267
Utility Safety Partners	Province-wide	1-800-242-3447
Poison & Drug Information Service	Province-wide	1-800-332-1414
Alberta Boilers Safety Association (ABSA)	Edmonton	1-780-437-9100
Government of Alberta Toll-Free Dialing	Province-wide	310-0000 then 10 digit number or 0 for Operator

Government Agencies – Federal

Resource	Contact	Cell/24 Hour
Government of Canada - DFO (Department of Fisheries and Ocean)	Canadian Coast Guard Western Region	1-800-889-8852
Environment and Climate Change Canada	Canada-wide	1-800-668-6767
CN Railway Co. - Police Service	Canada-wide	1-800-465-9239
Canadian Pacific Kansas City (CPKC) - Police Service	Canada-wide	1-800-716-9132
CANUTEC TDG - Emergency Reporting Line	Canada-wide	1-888-226-8832 *666 Cell Phone
Transportation Safety Board (CER Regulated Emergencies)	Pipeline Emergencies	1-819-997-7887
	Non-Pipeline Emergencies	1-403-299-2773
NAV Canada - Notice to Airmen	Canada-wide	1-866-992-7433

Emergency Services

Contact	Location	Telephone
Emergency Response Assistance Plan (ERAP)		
Emergency Response Assistance Canada	Canada-wide	1-800-265-0212
Ambulance - Municipal		
BC Ambulance Service	BC-wide	911 1-800-461-9911 where 911 not available
BC Ambulance Service (SAT Phones)	BC-wide	1-250-374-5937
Alberta Health Services - EMS	AB-wide	911
Alberta Health Services - Emergency Dispatch (SAT Phones)	AB-wide	1-780-624-3911
Ambulance - Oilfield		
911 Industrial Response Firemaster Oilfield Services	Dawson Creek BC/AB-wide	1-866-694-9111 1-877-342-3473
Air Ambulance		
BCAS Provincial Air Ambulance Coordination Centre	BC-wide	911 1-800-461-9911 where 911 not available
BCAS Provincial Air Ambulance Coordination Centre (SAT Phones)	BC-wide	1-250-374-5937
STARS [Redacted]	BC/AB-wide	1-888-888-4567 1-403-299-0932 (SAT Phones)
Hospitals		
<i>Emergency Services will determine the nearest hospital to transport patient(s) to in the event of an injury or fatality.</i>		
Fire Fighters - Municipal		
BC Wildfire Service	BC-wide	1-800-663-5555 *5555 on cellphone
Alberta Municipal Fire Department	AB-wide	911
Alberta Health Services - Emergency Dispatch (SAT Phones)	AB-wide	1-780-624-3911
Fire Fighters - Oilfield		
Trojan Safety Services Ltd. Firemaster Oilfield Services	Fort St. John BC/AB-wide	1-250-785-9557 1-877-342-3473

Industry Support Services

Contact	Location	Telephone
Air Quality Monitoring Equipment		
AAA Safety and Field Services	Fort St. John	1-250-262-3002
Trojan Safety Services Ltd	Fort St. John	1-250-785-9557
Communication Equipment (Radio/Telephones)		
Epscan Communications	Dawson Creek	1-250-782-9656
North Peace Communications Ltd. (Vincent Communications)	Dawson Creek	1-250-782-6664
Construction Company		
Borek Construction Ltd.	Dawson Creek	1-250-219-1887
Lindberg Construction Inc.	Dawson Creek	1-250-782-6700
Cranes / Picker Services		
SI's Oilfield Hauling Ltd.	Dawson Creek	1-250-784-5533
Sterling Crane	Fort St. John	1-250-263-0082
Helicopters		
Bailey Helicopters Inc.	Fort St. John	1-250-785-2518
Canadian Helicopters Limited	BC/AB-wide	1-780-429-6900
Safety Equipment / Personnel		
911 Industrial Response	Dawson Creek	1-866-694-9111
Firemaster Oilfield Services	BC/AB-wide	1-877-342-3473
Spill Response / Environmental Services		
WCSS	BC/AB-wide	1-866-541-8888
GFL Environmental Inc.	BC/AB-wide	1-800-435-1234
Supply Stores		
Apex Distribution Inc.	Dawson Creek	1-250-786-5497
Brogan Safety Supply Ltd.	Dawson Creek	1-250-784-0116
Tank Rentals		
Total Oilfield Rentals Ltd.	Dawson Creek	1-780-532-1994
Strad Inc.	Dawson Creek	1-866-778-2552
Tank Trucks		
CEDA	Dawson Creek	1-250-784-5151
Swamp Donkey Inc.	Dawson Creek	1-250-219-8370
Vac and Steam Trucks		
Vertex Resource Group Ltd.	Dawson Creek	1-250-719-0353
CEDA	Dawson Creek	1-250-784-5151
Well Control Equipment		
Capstone Blowout Recovery	BC/AB-wide	1-866-347-3911
Firemaster Oilfield Services	BC/AB-wide	1-877-342-3473
Wellsite Accommodations		
Vertex Resource Group Ltd.	Dawson Creek	1-780-532-7707
Total Oilfield Rentals Ltd.	Dawson Creek	1-780-532-1994

Note: The above listed corporate entities are subject to change without notice. Information regarding support services is accurate at time of printing

Spill Response – British Columbia

WCSS - Coop 9	Contact Information
Emergency 24-Hour Number	1-866-541-8888
Chairman: Don Brown Canadian Natural Resources Ltd.	Cell: 1-250-775-0364 don.brown@cnrl.com
Alt. Chairman: Jim Chramosta Shell Canada Limited	Ph: 1-250-794-3426 / Cell: 1-778-256-2685 jim.chramosta@shell.com
Alt. Chairman: Kaylin Salanski NorthRiver Midstream	Ph: 1-250-789-6476 / Cell: 1-250-919-7282 kaylin.salanski@nrm.com
Custodian: NorthRiver Midstream Kaylin Salanski	24hr: 1-250-262-3446 / Cell: 1-250-919-7282
Custodian: Radar Road, Rick	24hr: 1-250-774-5332 / Cell: 1-250-775-0036

Note: Please refer to WCSS.ca for all supporting documentation.

Spill Response – Alberta

WCSS – Coop 5	Contact Information
Emergency 24-Hour Number	1-866-541-8888
Chairman: Mike Doerksen PGI Processing ULC	Cell: 1-780-622-7358 mdoerksen@pembina.com
Alt. Chairman: Sandra Miller ARC Resources Ltd.	Ph: 1-587-202-0637 / Cell: 1-780-296-5822 smiller@arcresources.com
Alt. Chairman: Megan Bridger Ovintiv Canada ULC.	Ph: 1-403-303-1957 / Cell: 1-780-926-6339 megan.bridger@ovintiv.com
Custodian: ARC Resources Ltd. (117 St), Ron Toly, Sandra Miller:	24hr: 1-250-219-8180 / 1-587-202-0637
Custodian: ARC Resources Ltd. (Archie Warehouse), Sandra Miller	24hr: 1-587-343-5824 / 1-587-202-0637
Custodian: Silver Peak Services Martin Danny	24hr: 1-780-827-4776 / Cell: 1-780-827-8739
Custodian: Avenge Energy Services Inc.	24hr Dispatch: 1-780-617-0555 24hr: 1-780-524-3938
Custodian: Pembina Pipelines Dwayne Jones	(Main contact. Ask for foreman on call) Cell: 1-780-524-8877 Office: 1-780-524-3392 ext. 2844
Custodian: PGI Processing ULC - Kaybob Amalgamated Gas Plant, Michael Doerksen	24hr: 1-780-622-6274 Ph: 1-780-622-6250 / Cell: 1-780-622-7358

Note: Please refer to WCSS.ca for all supporting documentation.

Supporting Information Table

The table below indicates the location of CER supporting documentation in this emergency response plan.

Supporting Information	ERP Section
CER Distribution	Forward: Distribution List
CER Roles and Responsibilities	Jurisdictional Requirements: Canadian Federal Government – Section 9
CER Definitions of Incident Reporting	Jurisdictional Requirements: Canadian Federal Government – Section 9
CER Detailed Incident Report	Jurisdictional Requirements: Canadian Federal Government – Section 9
Notification Requirements for Key Government Agencies and Local Resources	Applicable Jurisdiction – Section 9
TSB Roles and Responsibilities	Jurisdictional Requirements: Canadian Federal Government – Section 9
Risk Assessment	Supplemental Field Information
Hazard Summary	Appendix: CANUTEC 2024 – Hazard Reference Tables – Section 11.3
CER Regulated Assets	Tupper Main CER – Asset Data
Maps	Tupper Main – Maps

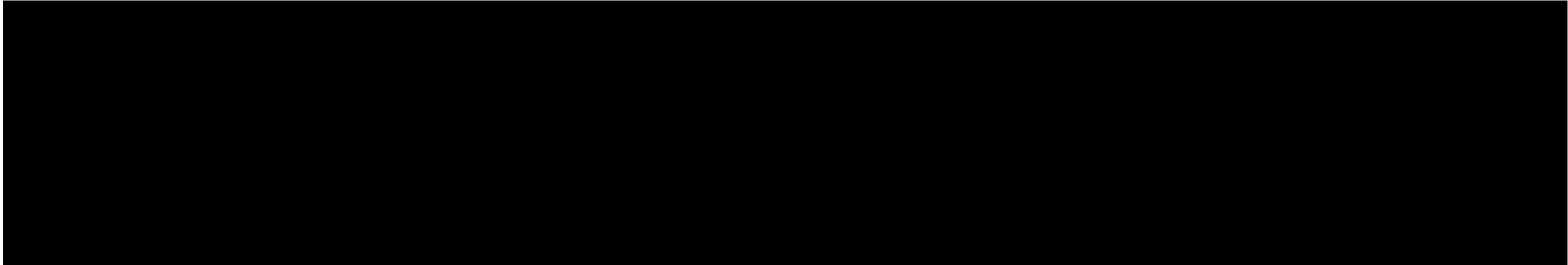

12.4 Supplemental Field Information

12.4.1 Field Specific Response Actions

Area Isolation

The Incident Commander has overall responsibility for isolating the hazard area. Access to the incident location will be restricted by responding personnel who shall:

- Establish roadblocks at required sites to secure identified HRZ.
- Ensure responders have proper safety equipment, i.e. PPE, air monitors, etc.
- Take air quality monitoring readings periodically for your safety and reposition as necessary.
- Record any incoming and outgoing vehicles and equipment.

Tupper Main Field Area

Highway 52 traverses the EPZ. Highway 52 will be isolated by Argo Road Maintenance Inc. accompanied by the RCMP. NorthRiver will assist with providing additional manpower and equipment, as required. If required, Argo Road Maintenance Inc. in conjunction with the RCMP and the Ministry of Transportation and Transit will establish detour routes/traffic points (see Sub-Section 12.1 Maps for pre-determined detour/traffic points).

Tupper West Field Area

Highway 52 and Highway 97 traverse the EPZ. Highway 52 and/or Highway 97 will be isolated by Argo Road Maintenance Inc. accompanied by the RCMP. NorthRiver will assist with providing additional manpower and equipment, as required. If required, Argo Road Maintenance Inc. in conjunction with the RCMP and the Ministry of Transportation and Transit will establish detour routes/traffic points (see Sub-Section 12.3 Maps for pre-determined detour/traffic points).

Notification

The Public Protection Group Supervisor will be responsible for notifying stakeholders and transients in the EPZ. If necessary, the Public Protection Group Supervisor may delegate notification duties to the Telephone Team Leader.

In a Level 1 Emergency, notification must be made to all stakeholders with special needs or who requested early notification. All stakeholders and locations with unknown phone numbers are deemed special needs and must be visited during a Level 1 Emergency. Impacted non-resident landowners (district lots) will be notified by pulling the applicable land title(s), as required.

In the event of a Level 2 or 3 Emergency, the NorthRiver Public Protection Group Supervisor will contact all Rights Holders and other area users in the EPZ.

See ERP map for more details.

Transients

Response personnel will be dispatched to the incident location to deliver evacuation notices during an emergency.

The Incident Commander and Public Protection Group Supervisor may also dispatch a helicopter (during daylight hours) equipped with a loud hailer to search the area for transients (industrial operators, area trappers, recreational users, etc). A Rover will drive on the road(s) within the HRZ to ensure that there are no transients.

The status of any transients spotted from the air would be communicated to the Public Protection Group Supervisor for follow-up. If the Rover encounters any parked vehicles in the EPZ, he/she will leave a Notice of Evacuation.

Evacuation

NorthRiver may decide to evacuate the HPZ if the emergency appears it will be of a long duration. NorthRiver cannot force an evacuation unless the local authority has declared a state of emergency; in which case, evacuation is mandatory.

The Public Protection Group Supervisor will dispatch Rovers or activate Telephoners to evacuate stakeholders to the designated Reception Centre. Pets should be evacuated with the residents to the Reception Centre.

Federal:

Restriction of Airspace	Agency
Notice to Airmen (NOTAM)	NAV Canada

British Columbia:

Closure Order	Agency
Petroleum Development Road	BCER
Forestry Roads	Ministry of Forestry
Numbered Highway	Ministry of Transportation and Transit

Alberta:

Road Closures:

- **Highway (HWY) Roads:** Alberta Transportation/511 Alberta and Parks Canada work with RCMP, local law enforcement and emergency services to determine highway closures.
- **Municipal Roads (Titled Land):** A landowner interested in requesting a road closure must contact their town, village, municipal, or county office to request to initiate the closure process.

[Road closures | Alberta.ca](#)

Shelter in Place

If there is no advanced warning to an incident, or if a release is of a short duration (several minutes to half an hour) the Public Protection Group Supervisor will initiate Shelter in Place procedures.

Stakeholders will be asked to remain inside and ensure all windows and doors are closed, and that all air intakes (furnace, stove, bathroom and dryer vents) are plugged to limit exposure to outside air.

The Public Protection Group Supervisor will notify sheltered stakeholders once the emergency has been stood down.

Ignition

If an immediate threat to human life exists and there is not sufficient time, the Incident Commander is authorized to ignite the release.

It is important that mobile air quality monitoring be dispatched as quickly as possible to the emergency site because specialized monitoring equipment can more accurately record readings in the emergency area.

12.4.2 Air Monitoring

There are a number of companies that provide air monitoring services in case of an emergency where either mobile or stationary air quality monitoring is required. The table below identifies the number of units, location and approximate response time, based on availability and road and weather conditions at the time of the emergency.

Company	Equipment	Number	Location	Response Time
AAA Safety and Field Services	SCBA air packs	2	Fort St. John	Immediate + travel time
	SABA air packs	6		
	1200' of hose	--		
	6-outlet manifolds	2		
	4500psi high pressure air bottles	8		
	Recharge line	1		
	Two stage high/low pressure regulators	2		
	3-way splitter for air lines	1		
	Pull tube Draeger gas detector	1		
	Fall protection harness and 6' lanyard	1		
	Signage, flags and flag poles, windsock, flagging tape	--		
	Fall protection harness and 6' lanyard	1		
	Downwind mobile air monitoring (van)	3		
Personnel	--			
Note: AAA Safety and Field Services has a total of eleven (11) 4500 psi Supplied Air Trailers. Each trailer contains the above-mentioned equipment. Extra equipment can be requested.				
Trojan Safety Services	Standalone Air Monitoring Units (Solar)	4	Fort. St. John & Grande Prairie	1 hour +travel time
	Air Trailers (Supplied Air)	--		3 hours + travel time
	Downwind Mobile Air Monitoring (Van) from GP	As required		
	Mobile Air Monitoring Unit	3-4		
	Stationary Air Monitoring Unit	As required		
	Roadblock Kits / Personnel	As required		
Ignition Kits	As required			
British Columbia Energy Regulator (not contract service)	Roaming Air Monitoring unit (RAM)	1	Fort. St. John	+/- TBD*
Note: The BCER mobile air monitoring unit would be dispatched as a resource of last resort. Responders would have to clearly demonstrate that there are no available units that could reach the incident location within a reasonable amount of time.				

12.4.3 Mutual Aid

The purpose of a Mutual Aid agreement is to clarify and agree upon a coordinated level of response for an emergency incident involving licensed NorthRiver Midstream Inc., and third-party operators.

NorthRiver Midstream Inc. has informal mutual aid agreements with the following.

Company Name	24 Hour Emergency Number
Advantage Energy Ltd	1-866-266-5623
ARC Resources Ltd.	1-403-292-0434
ATCO Gas (Alberta)	1-800-511-3447
ATCO Power (FN/Alberta)	1-800-668-5506
BC Hydro	1-800-224-9376
BC Hydro Fort Nelson	1-250-233-4239
Bench Creek Resources Ltd.	1-855-542-7241
Blue Sky Resources (SABA Oil and Gas & Zargon Oil and Gas Ltd.)	1-844-514-2462 / 1-403-264-9992
Bonavista Energy Corporation	1-866-971-8317
Canadian Natural Resources Ltd.	1-888-878-3700
Cenovus Energy Inc.	1-877-458-8080
Chinook Energy	1-877-365-1619
Coelacanth Energy Inc. (Leucrotta Exploration Inc.)	1-866-859-5962
Crew Energy Inc.	1-866-384-6240
Diamond LNG Canada Ltd.	1-403-262-6500
Enbridge – Westcoast Energy Inc.	1-800-663-9931
Enercapita Energy Ltd.	1-866-556-7938
EOG Resources Inc.	1-866-248-5020
Erikson National Energy Inc.	1-866-363-6100
GSE&R Canada Ltd.	1-877-414-7784
Kelt Exploration Ltd.	1-855-845-9787
Keyera Corp.	1-250-772-5508 / 1-866-377-7110
Logan Energy Corp.	1-587-770-2011
Murphy Oil Company Ltd.	1-888-999-0423
Ovintiv Canada ULC	1-403-645-3333
Paramount Resources Ltd.	1-866-362-1138
Pembina Gas Infrastructure Inc. (Veresen Midstream)	1-800-360-4706
Pembina Pipeline Corporation	1-800-360-4706

Company Name	24 Hour Emergency Number
Petronas Canada	1-844-299-2566
Plains Midstream Canada ULC	1-866-875-2554
Polar Star	1-866-741-6408
Procyon Energy Corporation	1-866-839-9746
Spartan Delta Corp.	1-403-266-8670
Storm Development Corp.	1-833-570-7997
Suguro Resources (Tourmaline Oil Corporation)	1-877-504-4252
TC Energy Corporation	1-888-982-7222
Tidewater Midstream and Infrastructure Ltd.	1-866-544-9875
Todd Energy Canada Ltd.	1-866-490-0343
Tourmaline Oil Corporation (Rising Star Resources Ltd. & Black Swan Energy Ltd.)	1-877-504-4252
Vermilion Energy Inc. (Leucrotta Exploration Inc.)	1-844-621-2858 / 1-844-621-2859

It must be agreed upon prior to any type of third-party response that the Company will remain the primary emergency responder, and that any assistance provided by third parties must be under the supervision of a Company representative. Furthermore, the party providing mutual aid must comply with all applicable Company policies and applicable government regulations.

If another Area Operator aids, the principal behind this assistance should remain as follows:

- Companies or individuals aiding are to provide the support outside the lease boundary. The focus will be to provide the manpower and support required for roadblock crews, rovers, resident contact, security, and evacuation co-ordination as required by the Company requesting the assistance.
- Third party responders will report to the Incident Commander or other coordinating position in the area.
- Individuals aiding retain the right to withdraw the assistance should his/her personal safety be jeopardized.

12.4.4 Authority Roles Coordination

All agencies listed below are contacted by NorthRiver Midstream and provided with the latest stakeholder brochure and their role and responsibilities to ensure up to date information regarding operations in their area.

Fields	Type of Agency	Agency Name	Provided Specific Roles	Provided Generic Roles
All Fields	RHA	Health Emergency Management BC, North (HEMBC) Owen Brokenshire Health Emergency Management Specialist	X	
All Fields	Local Authority	Peace River Regional District (Zone B-C-D-E) Kevin Clarkson, GM of Community Services	X	
Tupper Main	RHA	Alberta Health Services Director of Environmental Public Health	X	
Tupper Main	Local Authority	County of Grande Prairie No. 1 Trevor Grant, Fire Chief Chad Cormack, Deputy Fire Chief	X	

BC Regional Health Services

Emergency Response Roles & Responsibilities

Health Emergency Management BC, North (HEMBC)

HEMBC is a program under the Provincial Health Services Authority (PHSA). HEMBC provides the expertise, education, tools, and support specifically for the BC Health Sector to effectively mitigate, prepare for, respond to, and recover from the impacts of emergency events; ensuring the continuity of health services. There is a HEMBC team in each BC health authority. HEMBC-North deals specifically with Northern Health.

Roles and responsibilities:

- Maintain a 24-hour emergency/on call contact number for notification and activation of the health system in Northern BC (appendix I)
- Notify/activate the appropriate Northern Health programs (i.e. Public Health, Acute Care, etc.) based on the nature of the incident/emergency event.

Northern Health (NH)

Northern Health is the regional health authority responsible for providing health services to 300,000 people over an area of 600,000 square kilometers in the province of British Columbia. Services include:

- Acute (hospital) Care
- Public Health (Protection, Preventive and Population Health services)
- Mental Health and Addictions
- Home and Community Care

In the event of a major emergency/disaster, Northern Health will provide health care services within its capacity, and will activate its emergency response management plan(s).

NH Roles & responsibilities - PREPAREDNESS (PRE-EVENT):

- Participate with industry, local authority and other partners in the development of their Emergency Response Plans as it relates to health authority roles and responsibilities:
- Participate in stakeholder training and exercises associated with activation of an Emergency Response Plan, in which Northern Health or HEMBC have a role and responsibility (as resources allow);

NH Chief Medical Health Officer approval: July 5,
2016 Rev. Oct 2023- HEMBC North

**NH Roles & responsibilities - RESPONSE:**

- Activate internal health emergency management plans related to ongoing provision of services (listed above);
- Provide acute care and emergency services at existing Northern Health hospitals/health centres;
- Work with BC Emergency Health Services (Ambulance) and the BC Patient Transfer Network to transport patients to the appropriate levels of care;
- Apply and enforce the Public Health Act, and associated regulations;
- Provide advice/information to the stakeholders on the existing or potential public health effects of an incident (including drinking water safety, air quality, environmental contaminants, communicable disease prevention, re-occupancy of evacuated areas, etc.);
- Provide advice/information on the best methods for monitoring health effects from an incident.
- Assist in development of (joint) messaging for public information on emergency incidents;
- Provide guidance to stakeholders and local authorities on public health considerations in operating reception and evacuation centres, and group lodging facilities

NOTE: British Columbia Emergency Health Services (BCEHS - Ambulance) remains independent of Northern Health. If an ambulance is required please contact BCEHS via 911 (or the local contact number, if 911 is not available in your area).

NH Chief Medical Health Officer approval: July 5,
2016 Rev. Oct 2023 - HEMBC North



Appendix I

NH/HEMBC- Contact information

1. **For Emergency events that require immediate connection with Northern Health, please call :**
 - HEMBC on call number (24/7) **855-554-3622** (or 855-55-HEMBC)
 - HEMBC will notify/activate the appropriate Northern Health programs (i.e. Public Health, Acute Care, etc.) based on the nature of the event/ emergency. Please include this number in industry ERPS, for the use of permit holders in contacting Northern Health on an emergency basis.
 - **Please do NOT** include this number on Public Awareness Pamphlets for individual projects; the EMCR/Oil and Gas Commission's emergency number(s) is more appropriate, and the HEMBC 24/7 number is on record with those agencies.

2. **For non-urgent requests related to Emergency Response Plans, or emergency exercise planning/information, contact HEMBC North Director Mary Charters, at:**
 - 250-617-5288
 - HEMBC@northernhealth.ca

3. **For Environmental assessment inquires and general government consultation questions pertaining to health please email the NH Office of Health and Resource Development at:**
 - resource.development@northernhealth.ca

NH Chief Medical Health Officer approval: July 5,
2016 Rev. Oct 2023- HEMBC North

BC Local Authority**PEACE RIVER REGIONAL DISTRICT**

1981 Alaska Avenue, Box 810, Dawson Creek, BC, V1G 4H8
Tel: 250-784-3200, Fax: 250-784-3201. www.prrd.bc.ca

Local Authority (Regional District)

Peace River Regional District (PRRD) has a formal Emergency Management Plan, which outlines the measures and sources of assistance that can be obtained to support emergency response efforts, within their jurisdictional boundaries. Upon request from the BC Energy Regulator (BCER), the Regional District may address emergency response capabilities, expectations and preparedness. If required or requested the Regional District may activate their emergency plan in order to achieve any of the following:

- Work with the BCER's Emergency Operations Centre (EOC) if established
 - With remote support as a cooperating agency through the BCER Liaison Officer and/or,
 - In the BCER operations section as an assisting agency
- Provide support and assistance to ensure notification of endangered area residents
 - Mass Alerting
 - Notifications
- Provide support to coordinate the delivery of Emergency Support Services (ESS) to evacuated or effected residents
- If necessary, declaration of a State of Local Emergency to enact legislative powers including but not limited to:
 - Issuance of Evacuation Alerts, Orders and Rescinds (persons, livestock, and animals);
 - Acquire or use any land or personal property considered necessary to prevent, respond or alleviate the effects of an event (following BCEMS Model); and
 - Control or Prohibit Travel in the region for safety
- Assist with public information service (joint, BCER, Industry and local government)
- Assist with the provision of building re-entry procedures jointly with utility providers, industry, Northern Health, and Technical Safety BC.

Revised July 17, 2023

diverse. vast. abundant.

Oil & Gas Industry Emergency Preparedness and Response

Alberta Health Services (AHS) - Environmental Public Health (EPH) roles and responsibilities in public health emergency preparedness and response to the oil and gas industry are outlined below. The provision of services during an emergency depends upon our assessment of legislative responsibilities, impact to services, and business continuity.

EPH will endeavor to:

- Participate with the Licensee in the development of their Emergency Response Plans as it relates to the Environmental Public Health Program's role and responsibility.
- Provide the AHS Zone Single-Point-of-Contact (SPOC) emergency phone number to enable the Licensee to notify and alert the Zone of an emergency. From the initial notification or alert, AHS emergency response will fan out to and coordinate with other AHS programs and facilities as necessary. The 911 EMS services remain independent of the Zone SPOC notification/alert process.
- Participate with stakeholders in preparedness training and exercises associated with a Licensee's simulated activation of an Emergency Response Plan in which EPH has a role and responsibility.
- Participate in public information sessions during the Licensee's Emergency Response Plan development process when appropriate and as resources allow.
- Provide guidance to stakeholders and local municipal authorities in identifying sites suitable for establishing and operating an evacuation centre and/or reception centre, including operational requirements.
- Provide guidance to stakeholders on substances that may affect public health in consultation with the Zone Medical Officer of Health (MOH), including Alberta Health Acute Exposure Health Effects for Hydrogen Sulphide and Sulphur Dioxide information.
- Conduct assessments, inspections and give regulatory direction, when appropriate, to ensure the requirements of provincial legislation and EPH program areas of responsibilities for public health protection and disease prevention are maintained.

Notify the Zone Medical Officer of Health of any incident affecting or potentially affecting other AHS programs or facilities. The Zone MOH will notify and coordinate emergency response in other program areas and facilities as necessary.

For more information, visit Safe Healthy Environments
ahs.ca/eph

Oil and Gas Industry Emergency Preparedness and Response | 2

- Establish EPH emergency management operations, when appropriate, to support regional response efforts and liaise with the Government Emergency Operations Centre, Municipal Emergency Operations Centre and/or Industry Emergency Operations Centre, if needed.
- Assist the Zone Medical Officer of Health, local municipal authority, and Public Information/Communication officers in the development, issuance, and rescinding of public health, public evacuation and shelter-in-place advisories.
- Provide guidance to stakeholders on matters relating to evacuation of the public and/or public facilities, and the re-occupancy of those evacuated areas or facilities.
- Record and respond to health complaints or concerns from the public during and following an incident.
- Participate in stakeholder debriefings as necessary.

24 Hour Emergency Notification

Phone: 1-844-755-1788

Email: edp@ahs.ca

Use the phone number and email for all notifications across Alberta.

Contact us at 1-833-476-4743 or [submit a request online](#) at ahs.ca/eph.

PUB-0055-201711

©2017 Alberta Health Services, Safe Healthy Environments



This work is licensed under a [Creative Commons Attribution-Non-commercial-Share Alike 4.0 International license](#). You are free to copy, distribute and adapt the work for non-commercial purposes, as long as you attribute the work to Alberta Health Services and abide by the other license terms. If you alter, transform, or build upon this work, you may distribute the resulting work only under the same, similar, or compatible license. The license does not apply to content for which the Alberta Health Services is not the copyright owner.

This material is intended for general information only and is provided on an "as is," "where is" basis. Although reasonable efforts were made to confirm the accuracy of the information, Alberta Health Services does not make any representation or warranty, express, implied or statutory, as to the accuracy, reliability, completeness, applicability or fitness for a particular purpose of such information.

AB Local Authority**ROLE OF PRIMARY LOCAL AUTHORITY**

Initial contact for ERPs for the County of Grande Prairie No.1 is Trevor Grant, Fire Chief.

1) Trevor Grant, Fire Chief (Primary)

Office: (780) 532-9727

Cell: (780) 882-2975

tgrant@countypg.ab.ca

2) Chad Cormack, Deputy Fire Chief

Office: (780) 532-9727

Cell: (780)-933-6529

ccormack@countypg.ab.ca

3) Joulia Whittleton, Director Emergency Management

Office: (780) 532-9722

Cell: (780) 933-8712

jwhittleton@countypg.ab.ca

4) Lee Brachman, Deputy Director Emergency Management

Office: (780) 532-9727

Cell: (780) 547-5651

lbrachmann@countypg.ab.ca

RESPONSIBILITIES

The Emergency Services Act requires the local authority of each municipality to be responsible for Emergency Response Planning and for the direction and control of their emergency response in their respective jurisdiction (Local Authority).

The Local Authority:

- Review the Site-specific Emergency Response Plan
 - Initiates and manages the local municipal disaster services response
 - Dispatches representative(s) to the Emergency Operations Centre, when established and as required
 - If required, activates their municipal emergency operations centre and coordinates municipal activities at this centre
 - Upon request, may assist with setting up and administration of the Reception Centre
 - Assists with the arrangements of temporary accommodations for residents who have been evacuated
 - Assist with the establishing, set up and maintenance of roadblocks as resources and staff training permit
- Ensures that if available, local emergency services and resources are available to the level that they are trained

- Assists with off-site fire protection
- Activates the Emergency Public Warning System (EPWS) to alert public to life threatening hazards as required according to criteria set out by AEMA
- Supports operator in dealing with the emergency situation
- Initiate public protection methods as required
- If necessary, declares a local state of emergency to provide local authorities with special powers (mandatory evacuation, use of or entry into private property, conscription, demolition of private property structures for safety reasons, etc.)
- Establish a public information service, including use of the news media to inform and instruct the public of the emergency as required
- Assist as required with post incident damage assessment

RESOURCES

- The County has and may provide equipment and manpower in an offsite support role for fire protection and emergency mitigation. No County Fire personnel will work outside of their scope of practice. All County personnel will remain under immediate control and direction of a County Fire Officer or designate. The County Fire Service is manned 24 hours a day from the Clairmont and Dunes Fire Halls and will be dispatched through 911. All other stations in the County service area are Paid Response or Volunteer and will be dispatched through 911.
- The County has uniformed Level 1 Peace Officers. The RCMP performs all other policing, evacuation and notification duties. The Peace Officers would be mobilized at the request of the RCMP.
- The County has a large Public Works Department (divided into 3 zones), affiliated equipment and vehicles, and a staff that ranges from 140 in the winter to 240 in the summer. Manpower and equipment may be available to assist with roadblocks and county road closures depending on training and availability.

County of Grande Prairie Notification 24 hr. Phone Number 1-780-814-0280

For all Emergencies Dial 911

CHEMICALS AND DANGEROUS GOODS

The County of Grande Prairie Regional Fire Service has varying levels of Dangerous Goods Response. We provide primary response from 5 County owned stations to an Operations level, we also have 4 contracted partners that provide the same level of response for their respective areas. In a Dangerous Goods or hazardous chemical incident the County would only act in a support role to the primary responder.

The County has basic hazmat training and have foam units on all trucks. The County also has a mass spectrometer and can ascertain what type of chemicals are in the air.

12.4.5 Hazard Risk Analysis Results

The chart below identifies the high-risk hazards that are present at the Tupper Main & Tupper West areas of Operations:

Risk Level	Hazards	Controls & Response Actions	CANUTEC 2024
Critical	None Identified	N/A	Section 11.3 – Appendix
High	None Identified	N/A	Section 11.3 – Appendix
Moderate	Fire: Industrial/Facility	Section 7.20.1 - Facility Fires	Section 11.3 – Appendix
	Release: Chemical (e.g. produced water, cleaning agents)	Section 7.17 – Liquids Release – Site/Facility	Section 11.3 – Appendix
	Release: Gas (Sweet)	Section 7.15 Sweet Gas (Hydrocarbon) Release	Section 11.3 – Appendix
	Release: Gas (Sour)	Section 7.14 Sour Gas Release	Section 11.3 – Appendix
	Fire: Wildland/Grass/Forest	Section 7.20 – General Fire Response	Section 11.3 – Appendix
	Release: Liquid Product	Section 7.17 – Liquids Release – Site/Facility, Section 7.13 Spill Contingency Plan	Section 11.3 – Appendix
	Excessive Runoff from Facility	Section 7.13 Spill Contingency Plan	Section 11.3 – Appendix
Low	Pipeline Rupture	Section 7.19 – Blow Out Incident	Section 11.3 – Appendix
	Pipeline Strike/Leak (3-5 mm)	Section 7.19 – Blow Out Incident	Section 11.3 – Appendix
	Medical Event (Slips, Trips, First Aid, Heart Attack, etc.)	Section 7.10 – Injury/Fatality	Section 11.3 – Appendix
	Transportation/Vehicle Incident: On Site	Section 7.24 – Transportation Incident	Section 11.3 – Appendix
	Transportation/Vehicle Incident: Off Site Involving Company/Contractor Personnel	Section 7.24 – Transportation Incident	Section 11.3 – Appendix
	Threat or Suspicious Activity	Section 7.29 – Bomb Threat	Section 11.3 – Appendix
	Disgruntled Landowner/Employee/Contractor/Vendor	Section 7.9 - Site Security	Section 11.3 – Appendix
	Intruder/Squatter	Section 7.9 - Site Security	Section 11.3 – Appendix
	Landslide	Section 7.27.6 – Seismicity	Section 11.3 – Appendix
	Seismic Event: Earthquake	Section 7.27.6 – Seismicity	Section 11.3 – Appendix
Prolonged Power Outage	Refer to Business Continuity Plan	Section 11.3 – Appendix	